



INSTRUCTIONS

GEH-1770F

SUPERSEDES GEH-1770E

HANDBOOK REFERENCE 7270

DIFFERENTIAL VOLTAGE RELAYS

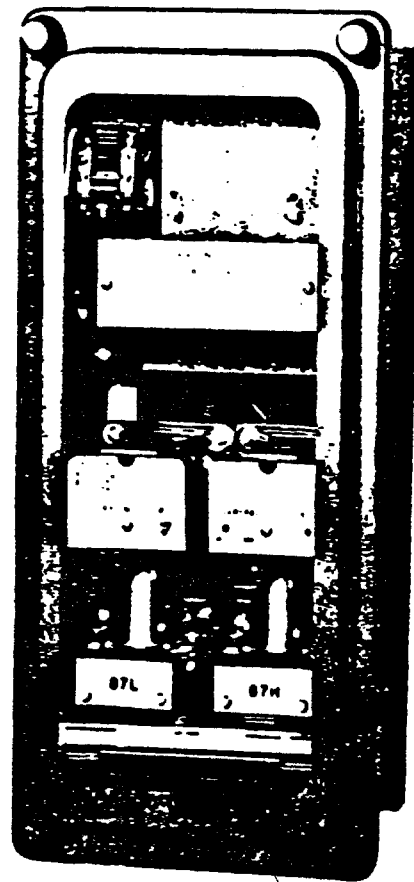

TYPES
PVD11C
PVD11D

GENERAL  ELECTRIC

CONTENTS

	<u>PAGE</u>
DESCRIPTION	3
APPLICATION	3
CONSTRUCTION	4
SEAL-IN UNIT	4
RATINGS	5
RANGES	5
THYRITE STACK	5
87L CONTINUOUS RATING	6
CONTACTS	6
SEAL-IN UNIT	6
CHARACTERISTICS	6
OPERATING PRINCIPLES	7
OPERATING CHARACTERISTICS	7
87L HIGH IMPEDANCE UNIT	7
THYRITE STACK	7
87H INSTANTANEOUS UNIT	8
BURDENS	8
CALCULATION OF SETTINGS	9
SETTING OF HIGH IMPEDANCE UNIT 87L	10
MINIMUM FAULT TO TRIP 87L	10
SETTING CURRENT UNIT 87H	11
SAMPLE CALCULATION	12
RECEIVING, HANDLING AND STORAGE	12
ACCEPTANCE TESTS	12
VISUAL INSPECTION	12
MECHANICAL INSPECTION	12
CRADLE AND CASE BLOCKS	12
CONTACTS MAIN UNITS	12
SEAL-IN UNIT CONTACTS	12
TARGET	12
ELECTRICAL INSPECTION	12
87L UNIT	12
87H UNIT	13
TARGET	13
THYRITE UNIT	13
INSTALLATION PROCEDURE	13
LOCATION AND MOUNTING	13
CONNECTIONS	13
VISUAL INSPECTION	13
MECHANICAL INSPECTION AND ADJUSTMENTS	13
TARGET SEAL-IN UNIT	14
87L UNIT	14
87H UNIT	14
PERIODIC TESTS AND ROUTINE MAINTENANCE	14
CONTACTS	15
PERIODIC TEST EQUIPMENT	15
ELECTRICAL TESTS	15
THYRITE UNIT	15
RENEWAL PARTS	15

DESCRIPTION

The Type PVD11C and PVD11D are single phase differential relays designed to provide instantaneous bus differential protection when used in conjunction with suitable current transformers. Three PVD relays and a lockout relay are required for combined phase and ground protection of a section of 3-phase bus. The Type PVD11C and PVD11D relays are mounted in a single ended M1 size drawout case and are provided with a target and seal in unit. See Figure 1 for outline and dimensions. The PVD11D includes two paralleled voltage limiting Thyrite stacks as opposed to the one Thyrite stack of the PVD11C which makes the PVD11D better suited for applications where high internal fault currents are encountered. See Figures 2 and 3 for the internal connections of the PVD11C and PVD11D respectively.

APPLICATION

The following comments on the application of Type PVD11C and PVD11D relays may be better appreciated if the operating principles, as detailed in the section on CHARACTERISTICS, are reviewed before proceeding. The Type PVD11C and PVD11D relays can be applied for bus protection in most cases where CT's having negligible leakage reactance are used. This generally includes any kind of current transformer with a toroidal core if the windings (on the taps used) are completely distributed about the core. The elementary diagram of the external connections for a typical application is shown in Figure 4.

A bus differential scheme utilizing Type PVD11C and PVD11D relays has certain advantages that simplify application considerations.

1. Standard relaying-type bushing current transformers may be used.
2. Performance for specific applications is subject to simple calculations.
3. Protection is extended easily if the number of connections to the bus is increased.

The following points must be considered before a particular application is attempted.

1. It is preferable that all the CT's in the bus differential circuit have the same ratio. When adding to an existing bus at least one CT in the new breaker should be ordered with same ratio as the bus differential CT's in the existing breakers. Assume that an existing bus having 600 ampere breakers is protected with PVD relays. In this application the 600/5 CT's associated with these breakers would be used on the full winding. If a new feeder having a 1200 ampere rating were to be added to this existing bus, the 1200 ampere breaker should be ordered with a 1200/10 CT for use in the bus differential circuit. If the differential circuit unavoidably includes different ratio CT's the application may still be possible, but special attention must be given to protection against overvoltage conditions. If one or more of the CT's in Figure 4 was a different ratio from the others it would appear that the simple solution would be to use the full winding of the lower ratio CT's and a matching tap on the higher ratio CT's. The high peak voltages that occur during an internal fault will be magnified by the autotransformer action of the tapped higher ratio CT's, and the peak voltages across the full winding of the higher ratio CT's may exceed the capability of the insulation in that circuit. Refer applications involving different ratio CT's to the local General Electric Sales Office.
2. Where all current transformers are of the same ratio the use of the full windings instead of taps should be used.
3. In any case, CT secondary leakage reactance must be negligible on the taps used.
4. It may be possible, although not desirable, to use the differential circuit CT's jointly for other functions. The performance of the system under these conditions can be calculated by including the added burden as part of the CT lead resistance. However, consideration must be given to the hazards of false operation due to extra connections and errors in testing the added devices. Note that the relays may trip if a CT is open circuited.

These instructions do not purport to cover all details or variations in equipment nor to provide for every possible contingency to be met in connection with installation, operation or maintenance. Should further information be desired or should particular problems arise which are not covered sufficiently for the purchaser's purposes, the matter should be referred to the General Electric Company.

To the extent required the products described herein meet applicable ANSI, IEEE and NEMA standards; but no such assurance is given with respect to local codes and ordinances because they vary greatly.

5. A Thyrite stack is included in the PVD relay to limit to safe values the peak voltage that can be developed during an internal fault. Refer to the section on CHARACTERISTICS for further explanation. In the process of limiting this voltage the Thyrite stack dissipates energy. It is important to check that the Thyrite stack can limit peak voltage to a safe value without suffering thermal damage. A procedure to check for safe operation is outlined in the section on RATINGS. The PVD11D is distinguished from the PVD11C in that it includes two paralleled Thyrite stacks while the PVD11C includes only one Thyrite stack. This permits the PVD11D to be used in cases where internal fault currents are high enough to cause the safe operating limits of the PVD11C to be exceeded. However, a Thyrite stack may be connected externally to a PVD11C to create the functional equivalent of the PVD11D.
6. The voltage limiting Thyrite stack is short time rated, and to protect it the contacts of an auxiliary lockout relay, device 86, short circuits the Thyrite stack. It is recommended, as shown in Figure 4, that the 86 contact be wired between studs 3 and 6 to short out the Thyrite stack only. Following 86 operation the 87H unit is inserted in the differential circuit as a straight overcurrent function allowing for the possibility of using the PVD to initiate a breaker failure timer.
7. When circuit breakers are to be bypassed for maintenance purposes or when any other abnormal set up is to be made, it is recommended that means other than simply opening the PVD contact circuit be used to avoid incorrect tripping. With the high impedance operating coil still connected in the differential circuit, voltages may be developed that exceed the continuous rating of the PVD. This may be avoided by removing the connection plug, or, if external means are required, by short circuiting studs 4 and 5 to stud 6.
8. If any of the bus differential CT's are protected by primary and/or secondary voltage limiting devices such as vacuum gaps, which might be the case if the bus differential zone included shunt capacitor banks, additional considerations are necessary to ensure a reliable application. Some means must be incorporated to prevent this protective equipment from shorting the operating coils of the PVD during internal faults. Such applications may be referred to the local General Electric Sales Office.
9. The external connection diagram of Figure 4 indicates that the differential junction, points A and D for the phase I relay, is located in the switchyard. For outdoor installations where the distance between the breaker and relay panel is great, it may be desirable to locate the differential junction in the switchyard since the resistance of the fault CT loop may otherwise be too large. Refer to the section on CALCULATION OF SETTINGS. Note that the cable resistance from the junction point to the relay is not included as part of the fault CT loop resistance. It is permissible to locate junction points at the panel providing that the resulting relay setting gives the desired sensitivity.
10. The 87L unit should be set no higher than 0.67 times the secondary excitation voltage at 10 amperes secondary excitation current (evaluated for the poorest CT in the differential circuit). The reason for this is explained in the section on CALCULATION OF SETTINGS.

The following information must be obtained before settings are determined for a particular application.

1. Determine the secondary winding resistance for all the CT's involved.
2. Obtain the secondary excitation curves for all the CT's involved.
3. The information required concerning cable resistance and fault currents will depend upon the analysis chosen in obtaining the 87L pickup setting. Refer to the section on CALCULATION OF SETTINGS for detailed considerations.

CONSTRUCTION

The Type PVD relays are assembled in the medium size single ended (M-1) drawout case having studs at one end in the rear for external connections. The electrical connections between the relay and case studs are through stationary molded inner and outer blocks between which nests a removable connecting plug. The outer block has the terminals for the internal connections.

Every circuit in the drawout case has an auxiliary brush, as shown in Fig. 12 to provide adequate overlap when the connecting plug is withdrawn or inserted. Some circuits are equipped with shorting bars (see internal connections in Figs. 2 and 3), and on those circuits, it is especially important that the auxiliary brush make contact as indicated in Fig. 12 with adequate pressure to prevent the opening

of important interlocking circuits.

The relay mechanism is mounted in a steel framework called the cradle and is a complete unit with all leads terminated at the inner block. This cradle is held firmly in the case with a latch at both top and bottom and by a guide pin at the back of the case. The connecting plug, besides making the electrical connections between the respective blocks of the cradle and case, also locks the latch in place. The cover, which is drawn to the case by thumbscrews, holds the connecting plugs in place. The target reset mechanism is a part of the cover assembly.

The relay case is suitable for either semiflush or surface mounting on all panels up to 2 inches thick and appropriate hardware is available. However, panel thickness must be indicated on the relay order to insure that proper hardware will be included. Outline and panel drilling is shown in Fig. 1.

A separate testing plug can be inserted in place of the connecting plug to test the relay in place on the panel either from its own source of current and voltage, or from other sources. Or the relay can be drawn out and replaced by another which has been tested in the laboratory.

The relays covered by these instructions include two plunger-type operating units: a "low-set" voltage unit, device 87L, and a "high-set" current unit, device 87H.

Device 87L is an instantaneous voltage unit having a high impedance operating coil connected across the a-c terminals of a full-wave rectifier. The rectifier is in turn, connected in series with a reactor capacitor combination tuned for resonance at rated frequency.

Device 87H is an instantaneous overcurrent unit with a low-impedance operating coil which is connected in series with Thyrite resistor disks. The two types of relays differ in the Thyrite-disk combination. The Type PVD11C relay has a stack of four Thyrite disks in its voltage limiting circuit. The Type PVD11D relay has two stacks of four Thyrite disks, connected in parallel.

Both operating units have a single circuit closing contact. These contacts and the contact of the seal-in unit are all connected in parallel.

SEAL-IN UNIT

SEAL-IN UNIT

A seal-in unit is mounted in the upper left corner of the relay (see Fig. 8). This unit has its coil in series and its contacts in parallel with the main contacts, so that, when the main contacts close, the unit operates and seals in. When the seal-in unit picks up, it raises a target into view. The target latches up and remains exposed until it is released by a manual operation of the reset button, which is located at the lower left corner of the cover.

RATINGS

RANGES

These relays are available for 50 or 60 Hertz. The standard operating ranges available are given in the table below. Factors which influence the selection of the operating range are covered under CALCULATION OF SETTINGS.

87L PICKUP (VOLTS)	CONTINUOUS RATING (VOLTS)	87H PICKUP AMPERES
75/300	150	2/50
100/400	150	4/100

For other ranges consult the local General Electric Sales Office.

THYRITE STACK

The peak voltage application limit for a PVD bus differential scheme is 2120 volts. The magnitude of peak voltage that can be developed depends upon the magnitude of internal fault current and the excitation characteristic of the poorest CT in the differential circuit. The energy dissipated by the Thyrite stack in limiting this peak voltage must not exceed the thermal limit of the stack.

The 4 disk Thyrite stack must limit peak voltage to 2120 volts (530 volts/disc) without exceeding a 4 cycle thermal limit of 7200 watt-seconds (225 watt-seconds/disc/half-cycle). Four cycles was chosen as a conservative figure for relay operating time including the lockout relay. Figure 5 indicates the area of safe operation for the PVD11C as a function of the knee point voltage, E_s , of the poorest CT connected to the PVD and the secondary value of the maximum bus fault current. Figure 6 indicates the area of the safe operation for the PVD11D. The curves of Figure 5 and 6 were calculated on the basis of secondary excitation curves for GE CT's that had a ratio of E_s to the voltage at 10 amperes excitation of approximately 0.55. Therefore, in applying these curves the larger of E_s determined in the normal manner or 0.55 times the excitation voltage at 10 amperes exciting current should be used.

87L CONTINUOUS RATING

The resonant circuit included in the 87L unit has a continuous voltage rating of 150 volts RMS. Refer to the section on ACCEPTANCE TESTS for precautions to take during testing.

CONTACTS

The current closing rating of the contacts is 30 amperes for voltages not exceeding 250 volts. The current carrying rating is limited by the seal-in units rating.

SEAL-IN UNIT

The PVD relay is provided with a universal target and seal-in unit having 0.2 and 2 ampere taps as indicated in the following tabulation:

Ratings of seal-in unit coil:

	AMPERES AC OR DC	
	2 Amp Tap	0.2 Amp Tap
Ohms (d-c)	0.13	7
Carry for tripping duty	30	6
Carry continuously	3.5	0.35
Min. target operating amps	2	0.2

CHARACTERISTICS

OPERATING PRINCIPLES

The operating principles of the PVD bus differential relay will be described with the aid of the external connection diagram in Figure 4. This diagram shows a bus section with 3 circuits. Note that the conventional differential circuit is used with the PVD relay which is connected in parallel with the secondaries of the current transformers.

Knowing that the PVD has a high impedance, consider the effect of an external phase-to-ground fault on phase 1. Each of the CT's associated with an infeeding circuit (i.e. those circuits supplying fault current to the external fault) will produce the secondary voltage necessary to drive its secondary current, as dictated by ratio, through its winding and leads. The CT in the faulted circuit will produce the secondary voltage necessary to force the total secondary fault current through its winding and leads. If all the CT's perform ideally, there will be negligible voltage across the PVD at the junction points A and D. Unfortunately, during fault conditions CT's do not always perform ideally since core saturation can cause a breakdown in CT ratio. Such core saturation is generally accentuated by d-c transients in the primary fault current, and any residual flux left in the core by a previous fault may add to the tendency to saturate.

In the example of Figure 4 the worst condition would be realized if the CT in the faulted circuit saturated completely losing all its ability to produce a voltage in its secondary. When a CT saturates completely its secondary impedance approaches the secondary winding resistance provided the secondary leakage reactance is negligible, as would be the case when completely distributed toroidal CT's are used. The CT's in the infeeding circuits would then have to produce enough voltage to force their secondary currents through their own windings and leads, as well as the winding and leads of the fault CT, unassisted. As a result a voltage would appear across the junction points A and D. Since the faulted circuit CT is assumed to be completely saturated, this voltage is equal to the total of the secondary currents from the remaining CT's multiplied by the resistance of the faulted circuit CT secondary windings added to the

lead resistance. This relatively small voltage (typically on the order of 200 volts or less) is, for the fault magnitude in question, the maximum voltage which could possibly appear across the PVD points A and D under any condition. Obviously the faulted circuit CT will not lose all its ability to produce an assisting voltage, and the CT's in the infeeding circuits may tend to saturate to some degree. Hence, in practice the voltage across the PVD will be something less than the IR drop mentioned above.

Consider the effect of an internal fault. The CT's on the infeeding circuits (i.e. those circuits supplying fault current to the internal fault) will attempt to produce sufficient voltage to drive their secondary currents through their own windings and leads as well as the windings and leads of the remaining CT's. In this case all the infeeding circuit CT's will be operating into the high impedance of the PVD relay in parallel with the exciting impedance of all the CT's. The voltage across the PVD at junction points A and D approaches the open secondary voltage that the CT's will produce. Although the RMS magnitude of voltage induced in a CT secondary for an open secondary condition is limited by core saturation, very high voltage peaks occur at the instant in time the rate of change of core flux is greatest. This is approximately when the flux is passing through zero. The peak voltage appearing across the PVD relay (assuming no Thyrite limiting) can be 1000 volts or higher. Even for a moderate internal fault, the 60 hertz component of this voltage will generally be in excess of the value calculated for the maximum external fault, and therefore the PVD can be calibrated so that it will not pickup at a voltage equal to that caused by the maximum external fault current but will pickup at a voltage less than that caused by the minimum internal fault current. Consequently, the PVD is selective between internal faults and external faults or load current.

OPERATING CHARACTERISTICS

The preceding paragraphs describe in simplified form the operating principles of the Type PVD11C and PVD11D high impedance differential relays. In practice the relay circuit has been further refined to secure better operating characteristics.

67L High Impedance Unit

The high impedance operating coil is fed through a series resonant circuit tuned to the fundamental frequency. It is desirable that the PVD relay have a wide range of pickup adjustment. The resulting change in inductive reactance of the plunger type voltage unit utilized would disturb the tuning of the resonant circuit. This is prevented by isolating the operating coil of the adjustable high impedance unit within a full wave rectifier. The operating time of the 87L unit depends on the magnitude of the fault current, the quality of the CT's employed, and the setting of the unit. For low and moderate fault currents this unit will generally operate in 2-4 cycles.

Thyrite Stack

CT saturation, as previously noted, limits the RMS value of the secondary voltage during an internal fault. However, peak voltage sufficiently high to overstress insulation may occur. To protect the PVD and the associated wiring insulation from these potentially excessive peak voltages a non-linear resistor, Thyrite, is placed across the 67L unit.

The PVD relays are all hi-potted in factory test at 3750 volts RMS between the coils and the frame and between the coils and the contacts. A 2500 volts RMS hi-pot is performed between the contacts and the frame. The peak value of these hi-pots is 5300 and 3500 volts, respectively. Consideration must be given to the insulation capabilities of the other devices that may be connected to studs 5 and/or 6 of the PVD relay. This includes terminal blocks, leads and cables, current transformers and any other device that may be in the differential circuit. Therefore, the application limits for the PVD bus differential scheme are based on an assumed hi-pot of 1500 volts RMS, 2120 volts peak.

87H Instantaneous Unit

To shorten the relay operating time on severe faults an instantaneous unit, device, 87H, is placed in series with the Thyrite stack. 87H is set to operate on the Thyrite current which flows on the occurrence of severe faults. The actual operating time of the 87H unit depends on its setting, the magnitude of the fault current, and the quality of the current transformers employed. In general, for moderate and high current faults this unit will operate in one-half to one and one-half cycles.

BURDENS

During normal operating conditions or when an external fault occurs, the PVD relay burden is not imposed on any CT. The burden is of value in determining the sensitivity of the relay to internal faults as described in the section on CALCULATION OF SETTINGS. For this purpose, the resonant circuit can be

assumed to have a constant resistance of 2600 ohms and the Thyrite stacks in the PVD11C and PVD11D to have the RMS volt-ampere characteristics shown in Figure 7. Use the appropriate curve in Figure 7 depending upon whether the PVD11C or PVD11D is used.

CALCULATION OF SETTINGS

The formulas and procedures described in the following paragraphs for determining relay settings assume that the relay is connected to the full winding of the differentially connected CT's. It is further assumed that the secondary winding of each CT has negligible leakage reactance.

SETTING OF HIGH IMPEDANCE UNIT 87L

If it is assumed that an external fault causes complete saturation of the CT in the faulted circuit, the current forced through this secondary by the CT's in the infeeding circuits will be impeded only by the resistance of the winding and leads. The resulting IR drop will be the maximum possible voltage which can appear across the PVD relay for that external fault. The setting of the high impedance 87L unit can be expressed as:

$$V_R = 2 (R_S + PR_L) \frac{I_F}{N} \quad (1)$$

where: V_R = pickup setting of 87L unit

R_S = d-c resistance of fault CT secondary windings and leads to housing terminal (At highest expected operating temperature)

R_L = single conductor d-c resistance of CT cable for one way run from CT housing terminal to junction point (at highest expected operating temperature)

P = 1 for three phase faults; 2 for single phase to ground faults

I_F = external fault current - primary RMS value

N = CT ratio

The multiplier 2 is included in equation (1) to provide a reasonable safety factor.

The methods of utilizing equation (1) are outlined below:

Method I (Exact Method):

- a) determine the maximum three phase and single phase to ground fault currents just off each of the n breakers.
- b) the value of R_L is the cable d-c resistance from the junction point to the fault CT being considered.
- c) for each breaker in turn calculate V_R separately utilizing the associated maximum external three phase fault current with $P=1$ and then maximum external single phase to ground fault current with $P=2$.
- d) use the highest of the $2n$ values of V_R so obtained.

Method II (Simplified Conservative Method)

- a) use the maximum interrupting rating of the circuit breaker as the maximum external single phase to ground fault current.
- b) the value R_L is based on the distance from the junction point to the most distant CT.
- c) calculate a value for V_R using $P=2$.
- d) this value of V_R becomes the pickup setting.

Generally, Method I will produce a lower pickup setting than Method II. There are intermediate approaches between the extremes of Method I and II that may be utilized in determining 87L pickup. One such approach is to use an R_L value as described in Method II and calculate two values for V_R , the first associated with the actual maximum external three phase fault and $P=1$.

The second value of V_R is associated with the maximum external single phase to ground fault and $P = 2$. The higher of these two values would be selected as the 87L pickup setting. A similar but more conservative approach would be to use maximum internal three phase and single phase to ground fault currents rather than external values.

The user should begin with Method II. If the sensitivity resulting from the calculated value of V_R , determined as outlined in the following section, MINIMUM FAULT TO TRIP 87L, is not adequate then either Method I or an intermediate approach should be used. If the 87L pickup resulting from Method II proves to yield an adequate sensitivity, a unique advantage is realized since then the 87L pickup setting does not require recalculation following changes in system configuration that result in higher bus fault magnitudes.

As previously noted (see OPERATING PRINCIPLES in the section on CHARACTERISTICS), the pessimistic value of voltage determined by equation (1), for any of the methods outlined, is never realized in practice. The CT in the faulted circuit will not saturate to the point where it produces no assisting voltage. Furthermore, the condition which caused the fault CT core to saturate also tends to saturate the cores of the CT's in the infeeding circuits which results in a further decrease in voltage across the PVD. These effects are not readily calculated. However, extensive tests on bushing CT's used in General Electric circuit breakers, under simulated fault conditions, have resulted in the establishment of a so called "performance factor" which can be determined for each application. The expression for 87L pickup is then written:

$$V_R = 2K (R_S + PR_L) \frac{I_F}{N} \quad (2)$$

where: K = performance factor

The performance factor K is not a constant for a given bushing CT, but varies for each installation depending on the value of $(R_S + PR_L) I_F$. K is readily determined from the curve of Figure 8 which is based on test data. The use of this curve is explained in the section on SAMPLE CALCULATIONS which follows.

It is important to realize that the curve of Figure 8 is dependent upon the excitation curve of CT's used in obtaining the data. A different curve could result if current transformers having excitation curves of a different shape were tested. However, Figure 8 may be used with confidence for the majority of cases involving bushing type current transformers.

It is desirable for the pickup voltage of the 87L unit to plot below the knee of the excitation curve (i.e. point on the excitation curve where the slope is 45°) of all the CT's in use. However, it is permissible for the 87L pickup voltage to be higher than the knee point voltage. The maximum setting for the 87L unit is equal to the secondary excitation voltage at 10 amperes secondary excitation current (evaluated for the poorest CT in the differential circuit) multiplied by 0.67.

$$V_R (\text{max.}) = (\text{Volts at } I_e = 10a) 0.67 \quad (3)$$

A maximum value is established for the 87L unit pickup setting since a substantial increase in RMS 87L voltage above the pickup value should be realized for fault currents that are significantly greater than the minimum internal fault current required to just operate the 87L unit. With the 87L pickup voltage above the maximum recommended value, any reasonable increase in fault current over the minimum value may not produce an appreciable increase in secondary RMS voltage. The performance factor K in equation (2) should not be used unless equation (1) results in an 87L setting that exceeds the maximum value given by equation (3).

MINIMUM FAULT TO TRIP 87L

After the pickup setting of 87L has been established for an application, a check should be made to determine the minimum internal fault current which will just cause the unit to operate. If this value is less than the minimum internal fault current expected, the pickup setting is suitable for the application. The following expression can be used to determine the minimum internal fault current required for a particular 87L pickup setting:

$$I_{\text{min.}} = \left[\sum_{x=1}^n (I_e)_x + I_r + I_1 \right] N \quad (4)$$

- where:
- I_{min} = minimum internal fault current to trip 87L
 - n = number of breakers connected to the bus (i.e. number of CT's per phase)
 - I_e = secondary excitation current of individual CT at a voltage equal to pickup of 87L
 - I_r = current in 87L unit at pickup voltage = $V_R/2600$
 - I_1 = current in Thyrite unit at 87L pickup voltage (see Figure 7)
 - N = CT ratio

The values of $(I_e)_1$, $(I_e)_2$, etc. are obtained from the corresponding secondary excitation characteristics. The first term in equation (4) reduces to nI_e if it is assumed that all CT's have the same excitation characteristic. The relay current I_r can be determined from the resistance of the resonant circuit, assumed to be constant at 2600 ohms. That is:

$$I_r = V_R/2600 \tag{5}$$

The current drawn by the Thyrite unit I_1 can be obtained from the RMS voltage characteristics of Figure 7.

SETTING CURRENT UNIT 87H

The purpose of the 87H unit is to provide instantaneous operation for extremely severe internal faults. It should thus be set for as low a pickup as possible without risk of false operation on an external fault. For the worst external fault condition the Thyrite stack is subjected to the voltage resulting from a fully offset current flowing through the resistance of the secondary winding and leads of the saturated fault CT. Since the 87H unit responds to the first cycle of offset voltage any decay in the offset wave should be disregarded.

The correct setting of the 87H unit is determined from either the curves of Figure 9 or the curves of Figure 10. The curves of Figure 9 determine the RMS current which will flow in the Thyrite stack when a fully offset voltage is applied. For convenience the ordinate is plotted in terms of symmetrical RMS volts. The voltage read on the ordinate should be the value of V_R determined from equation (1). Under no circumstances should the performance factor K be used in determining the 87H unit setting. Use the appropriate curve in Figure 9 depending upon whether the PVD11C or PVD11D is used. Note that for the curves of Figure 9 it is assumed the standard Thyrite stack connections are used. Four disks in series comprise the standard PVD11C Thyrite stack, and four disks in series paralleled with four disks in series comprise the standard PVD11D Thyrite stack.

The curves in Figure 9 are plotted assuming the voltage applied to the Thyrite stack and 87H unit in series is a fully offset sine wave that is the product of a fully offset secondary fault current and the fault CT loop resistance. However, as the fault current and voltage across the Thyrite increase, the current drawn by the non-linear Thyrite resistance becomes significant. This pulse of Thyrite current subtracts from the secondary fault current causing the voltage across the Thyrite stack to deviate from the fully offset sine wave configuration. The curve of Figure 9 will thus be inaccurate in the pessimistic direction at higher voltage values. Figure 9 should not be used to determine 87H pickup setting for values of V_R above 350 volts. The set of curves of Figure 10 is furnished for use in cases where V_R exceeds 350 volts. Figure 10 shows a family of curves for various values of $(R_S + PR_L)$, the total resistance of the fault CT loop including winding and cable resistance. These curves show the RMS value of current at which the 87H unit in the PVD11C should be set if a fully offset current from the infeding circuit CT's enter the junction of the Thyrite circuit and the fault CT loop. Select the curve for the resistance closest to the actual fault CT loop resistance or interpolate between curves for greater accuracy. When using the curves of Figure 10 to determine the pickup setting of the 87H unit in the PVD11D read into the curves at a total fault current that is one half of the actual value. Use the curve that indicates twice the actual resistance and then multiply by 2 the current value read from the abscissa to obtain the PVD11D 87H unit setting.

SAMPLE CALCULATION

The various steps for determining the settings of a PVD11C relay in a typical application will be explained with the aid of a worked example. Assume the protected zone includes 5 breakers all rated at 69KV, 150MVA, 1200 amperes with a maximum interrupting rating of 14,500 amperes. The excitation curve for the 1200/5 bushing CT's in these breakers is shown in Figure 11.

The 87L unit setting will first be determined by using Method II as described in the preceding section on SETTING OF HIGH IMPEDANCE UNIT 87L. The value of R_s from Figure 11 is .080 ohm, (.0029) (240, + 0.113. Assume that the longest CT cable run is 442 feet and that #10 copper wire is used. The one way resistance at 25°C is then 0.450 ohms. Resistance values of wire at 25°C or at any temperature t_1 may be corrected to any other temperature t_2 by means of the following equation:

$$R_{t2} = 1 + \alpha (t_2 - t_1) R_{t1} \quad (6)$$

where:

R_{t1} = resistance in ohms at t_1 , °C

R_{t2} = resistance in ohms at t_2 , °C

α = temperature coefficient of resistance at t_1

For standard annealed copper $\alpha = 0.00385$ at $t_1 = 25^\circ\text{C}$. If the maximum expected operating temperature is 50°C, the value of R_L is:

$$R_L = R(50^\circ\text{C}) = 0.450 \left[1 + .00385 (50 - 25) \right]$$

$$R_L = 0.45 (1.096) = 0.494$$

Substituting the various quantities in equation (1):

$$V_R = 2 (0.80 + 2 (0.494)) \frac{14500}{240}$$

$$V_R = 216 \text{ volts}$$

Referring to Figure 11, it may be verified that V_R is below the knee point voltage of the CT excitation curve and is satisfactory in that regard. In some cases it will be found that the value of V_R , as determined from equation (1), will exceed the maximum value given by equation (3); whereas if equation (2) is used the value of V_R will be less than the maximum allowable value.

The relay sensitivity is obtained from equation (4) as follows:

$$I_{\min} = 5(0.05) + \frac{216}{2600} + 0.085 \quad 240$$

$$I_{\min} = 100 \text{ amps (primary)}$$

Assuming that the minimum internal primary fault current is above 100 amps means that the pickup setting of 216 volts is adequate.

The Thyrite stack should be checked for safe operation by means of Figure 5. The knee point voltage of the poorest CT is determined by 0.55 times the 10 ampere E_s value from the excitation curve of Figure 11 (see top of page 6). Thus, use $0.55 \times 590\text{v} = 324$ volts for the abscissa in Figure 5. The ordinate value for Figure 5 is the maximum breaker interrupting capacity divided by the CT ratio, or $14,500/240 = 60.5$ amperes. It can be seen from Figure 5 that this point is well within the area of safe operation for the standard PVD11C Thyrite stack.

In this example, the value of V_R from equation (1) is 216 volts, and hence Figure 9 should be used in setting 87H. The curve for the PVD11C in Figure 9 indicates that a 1.6 ampere setting of the 87H unit would be safe. Since the minimum setting of the 87H is 2 amperes, the unit would be set at this pickup value.

RECEIVING, HANDLING AND STORAGE

These relays, when not included as a part of a control panel will be shipped in cartons designed to protect them against damage. Immediately upon receipt of a relay, examine it for any damage sustained in transit. If injury or damage resulting from rough handling is evident, file a damage claim at once with the transportation company and promptly notify the nearest General Electric Apparatus Sales Office.

Reasonable care should be exercised in unpacking the relay in order that none of the parts are injured or the adjustments disturbed.

If the relays are not to be installed immediately, they should be stored in their original cartons in a place that is free from moisture, dust and metallic chips. Foreign matter collected on the outside of the case may find its way inside when the cover is removed and cause trouble in the operation of the relay.

ACCEPTANCE TESTSVISUAL INSPECTION

Check the nameplate stamping to insure that the model number and rating of the relay agree with the requisition.

Remove the relay from its case and check that there are no broken or cracked molded parts or other signs of physical damage, and that all screws are tight.

MECHANICAL INSPECTIONCradle and Case Blocks

Check that the fingers on the cradle and the case agree with the internal connection diagram. Check that the shorting bars are in the correct position. Check that each finger with a shorting bar makes contact with the shorting bar. Deflect each contact finger to insure that there is sufficient contact force available. Check that each auxiliary brush is bent high enough to contact the connection plug.

Contacts Main Units

Operate each plunger unit by hand and check that it moves freely without catching or binding. Observe the contact action. On both units the stationary member of the normally closed contact should follow the moving contact for $.030 \pm .010$ inch. As the normally closed contact just opens there should be $.045 \pm .010$ inch gap between the two members of the normally open contact. The upper (normally open) contacts should close $.060 \pm .010$ inch before the end of the armature travel. The force required to deflect the upper stationary contact away from its lower stop should be 40 to 60 grams measured at the contact tip. With the armature held or blocked in the picked up position, the force required to deflect the normally closed contact away from its stop should be 15 ± 5 grams. Even though the normally closed contacts have no electrical connections, they must be adjusted as described so that the relay will have the correct transient response.

Seal-In Unit Contacts

Pick up the target unit armature by hand, both of the bridging contacts should close at, or very close to, the same position. After both of the contacts are closed, there should be at least $.020$ inch additional armature travel measured at the contacts. This can be most easily checked by putting a $.010$ inch gauge between the armature and the polepiece and checking that both contacts still close when the armature is pushed closed. With the armature held closed, the moulded protrusion on the contact carrier should hold the armature at least $.015$ inch from the pole piece.

Target

When the armature is picked up by hand the orange target should appear. When the armature is released the target should remain in view. When the reset rod is depressed the target should drop from view.

With the armature held up by hand verify that the target is not at the end of its travel by pushing it upward with a sharp instrument. There should be a definite movement of at least $.015$ inch. While closely observing the target, release the armature. There should be a definite downward movement of at least $.010$ before the target is caught by the latch.

ELECTRICAL INSPECTION87L Unit

The 87L unit is shipped from the factory with the plunger set for the lowest pickup voltage. Mechanically the bottom of the plunger will be aligned with the highest of the four marks on the calibrating tube. As the relay is continuously rated at the lowest pickup voltage, the lockout relay shown in Figure 13 may be omitted. Suddenly apply the voltage, starting from above the expected pickup and lowering the voltage on successive trials. The lowest voltage at which the contacts close is the pickup voltage.

87H Unit

It is not advisable to check the pickup of the 87H unit by applying the required voltage and current to studs 5 and 6. The required power is high and can damage the various units of the relay. Instead apply the required current to studs 3 and 4 using an external current limiting impedance if needed. The 87H unit is shipped set for its minimum pickup. Pickup should be the minimum value \pm 15 percent.

Target

The target unit should be tested using smooth direct current. Unfiltered rectified AC will not give the same characteristics. Block one of the main units closed and apply a variable dc current to studs 1 and 2. The target seal in unit should pickup between 7C and 9S percent of tap when the current is gradually increased. Dropout should be 25 percent of tap or greater when the current is decreased gradually. Pickup should be measured with the target reset.

Thyrite Unit

* Apply 120 volts direct current to studs 3 and 6, the current should be between .005 and .012 amperes for PVD11C and between .010 and .024 amperes for PVD11D relays. As the thyrite is very voltage sensitive, the voltage should be set carefully. Also, any meter error in the voltmeter will be magnified 4 to 5 times; that is, a three percent meter error will affect the current 12 to 15 percent.

INSTALLATION PROCEDURE

LOCATION AND MOUNTING

The relay should be mounted on a vertical surface in a location reasonable free from excessive heat, moisture, dust and vibration. The relay case may be grounded, if desired, using at least No. 12 B & S gage copper wire. The outline and panel drilling diagram for the Type PVD relays is shown in Fig. 1.

CONNECTIONS

The internal connection diagrams for the Type PVD11C and Type PVD11D relays are shown in Figs. 2 and 3, respectively. The elementary diagram of the external connections for a typical application is shown in Fig. 4.

Note in Fig. 4, that when the relay is installed, a connecting jumper should be placed between terminals 4 and 5, and that terminals 5 and 6 are then connected across the differential junction points A and B of the several CTs. A shorting bar is provided between 5 and 6 so that as the connection plug of the relay is withdrawn, the differential circuit will not be opened.

The midpoint between the Thyrite stack and unit 87H is connected to terminal 3. This makes it possible to test or calibrate unit 87H without the necessity of passing high current through the Thyrite. It also makes it possible to short-out the 87H coil if its operation is not desired.

The external connections in Fig. 4 indicate that the differential junction, points A and B, should be located in the switchyard. For outdoor installations where the distance between the breaker and relay panel may be great, this may be important since the resistance through the fault CT loop may otherwise be too large. It is satisfactory to locate the junction points at the panel providing that the necessary relay setting gives the desired sensitivity.

There should be only one ground connection in the secondary circuit. This is shown in the external connection diagram of Figure 4.

The voltage limiting Thyrite is short-time rated and to protect it the contacts of the auxiliary short circuits the differential circuit.

CAUTION: UNDER NO CIRCUMSTANCES SHOULD THE RELAY BE PLACED IN SERVICE WITHOUT THE THYRITE VOLTAGE-LIMITING CIRCUIT CONNECTED; I. E., WITHOUT A JUMPER BETWEEN TERMINALS 4 AND 5. OTHERWISE, THE RELAY AND SECONDARY WIRING WILL NOT BE PROTECTED FROM THE HIGH CREST VOLTAGES WHICH RESULT FROM AN INTERNAL FAULT.

VISUAL INSPECTION

Repeat the items described under Acceptance Tests - Visual Inspection.

MECHANICAL INSPECTION AND ADJUSTMENTS

Repeat the items described under Acceptance Tests - Mechanical Inspection.

TARGET/SEAL-IN UNIT

Set the target/seal-in unit tap screw in the desired position. The contact adjustment will not be disturbed if a screw is front transferred from the left contact to the desired tap position on the right contact and then removing the screw in the undesired tap and transferring it to the left contact.

87L UNIT

The 87L unit can be adjusted at any voltage within the 4/1 range shown on its calibration plate. Four specific calibration values are shown on the plate which correspond with four markings on the calibration tube. These markings indicate the position of the lower edge of the armature in its de-energized position, to give the specified pick up points.

The vertical position of the armature can be changed by turning it on the threaded plunger rod. The armature is held in position by an internal locking spring which requires no adjustment. The 87L unit, unless otherwise specified on the requisition, will be set at the factory to operate at its minimum pick up voltage. If the unit is to be set at some other point, as determined from Table I or by calculation, the calibration marks should be used as a guide in making a rough adjustment and the test circuit shown in Fig. 13 should then be used to make an exact setting.

Note in Fig. 13, that when the test plug is inserted in the relay, the current transformer secondaries are shorted by means of the link between the outer terminals 5 and 6. The adjustable test voltage is applied across terminals 5 and 6 of the relay, that is, across the resonant circuit which includes the 87L unit. Since the continuous voltage rating of the resonant circuit is only 150 volts, it is recommended that a hand-reset lockout relay be used in the test set-up, if the desired 87L setting is to be above this figure.

The following procedure should be followed in checking pickup of 87L unit. Start with a test voltage considerably higher than the expected operating point. Lower the test voltage by successive small increments, closing the test switch at each point. The lockout relay will operate each time, protecting the resonant circuit. Eventually, a point will be reached where the 87L unit will just fail to operate. The preceding voltage value can be taken as the pickup value of the 87L unit with reasonable accuracy. At the point where the 87L unit fails to pick up, the test voltage must be removed at once to prevent damage to the relay.

If the 87L unit setting is to be less than the 150 volt continuous rating, it will not be necessary to use the lockout relay. The volt-meter used must have high internal impedance.

87H UNIT

The operating coil of the 87H unit is tapped to provide three separate pick up ranges. The desired range can be selected by means of links on the molded base at each side of the coil. The calibration plate indicates the correct position of the links for each range. For each link arrangement, the pick up current can be varied over a 4/1 range by means of the armature. When testing the 87H unit apply the current through studs 3 and 4. Increase the current gradually until the unit picks up.

It is desirable to check the external trip circuit wiring to the relay as well as the relay itself by operating one of the relay units by hand and allowing it to trip the breaker or lockout relay. Observe that the target operates when this is done.

PERIODIC TESTING AND ROUTINE MAINTENANCE

In view of the vital role of protective relays in the operation of a power system it is important that a periodic test program be followed. It is recognized that the interval between periodic checks will vary depending upon environment, type of relay and the user's experience with periodic testing. Until the user has accumulated enough experience to select the test interval best suited to his individual requirements it is suggested that the points listed under INSTALLATION PROCEDURE be checked at an interval of from one to two years.

Check the items described under Acceptance Tests - Visual Inspection and Mechanical Inspection. Examine each component for signs of overheating, deterioration or other damage. Check that all connections are tight by observing that the lockwashers are fully collapsed.

CONTACTS

Examine the contacts for pits, arc or burn marks, corrosion, and insulating films. For cleaning contacts, a flexible burnishing tool should be used. This consists of a flexible strip of metal with an etched-roughened surface resembling in effect a superfine file. The polishing action is so delicate that no scratches are left, yet it will clean off any corrosion thoroughly and rapidly. Its flexibility insures the cleaning of the actual points of contact. Do not use knives, files, abrasive paper or cloth of any kind to clean relay contacts.

PERIODIC TEST EQUIPMENT

A test set is available for the periodic testing of PVD relays. It is intended for mounting on the panel adjacent to the relays. In addition to testing the relays, it also checks the current transformers for open or short circuits and incorrect wiring. This Test set is more fully described in Instruction Book GEI-50290.

ELECTRICAL TESTS

Pickup of the 87L and 87H units should be measured and the results compared against the desired setting. If the measured value is slightly different from that measured at a previous time this is not necessarily an indication that the relay should be readjusted. The errors of all the test equipment is often additive and the total error of the present setup may be of opposite sign from the error at the previous periodic test. Instead of readjusting the relay it is recommended that, if the apparent error is acceptable, no adjustment be made and that the error be noted on the relay test record. After sufficient test data has accumulated, it will become apparent whether the measured errors in the setting are due to random variations in the test conditions or are due to a secular drift in the characteristics of the relay. Slow changes can be predictive of gross failure will be detected with this procedure before they can be detected in any other manner. Recalibrating the relay at each test interval, in contrast, tends to mask them.

THYRITE UNIT

Repeat the test described under Acceptance Tests - Electrical Inspection.

RENEWAL PARTS

It is recommended that sufficient quantities of renewal parts be carried in stock to enable the prompt replacement of any that are worn, broken, or damaged.

When ordering renewal parts, address the nearest Sales Office of the General Electric Company, specifying the quantity required and describing the parts by catalogue numbers as shown in Renewal Parts Bulletin No. GEF-3798.

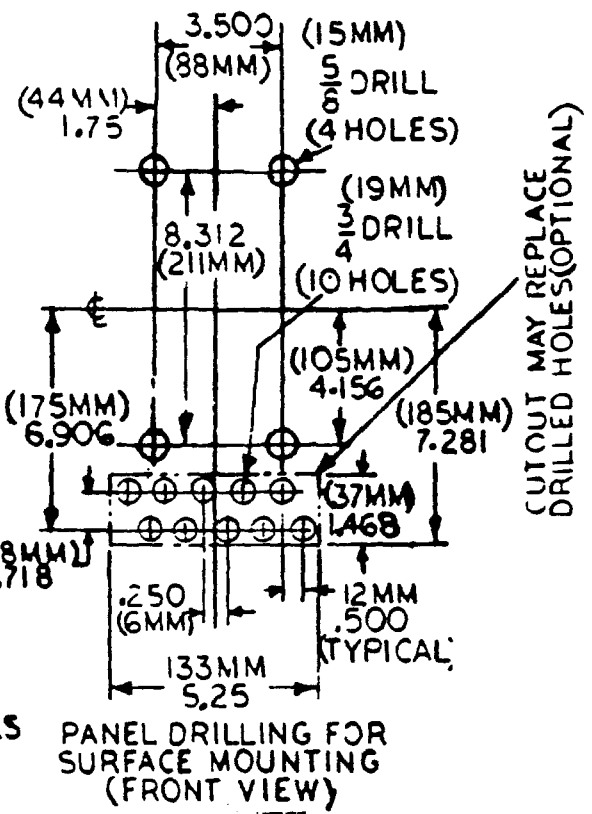
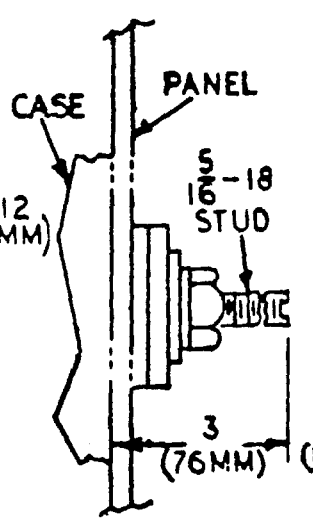
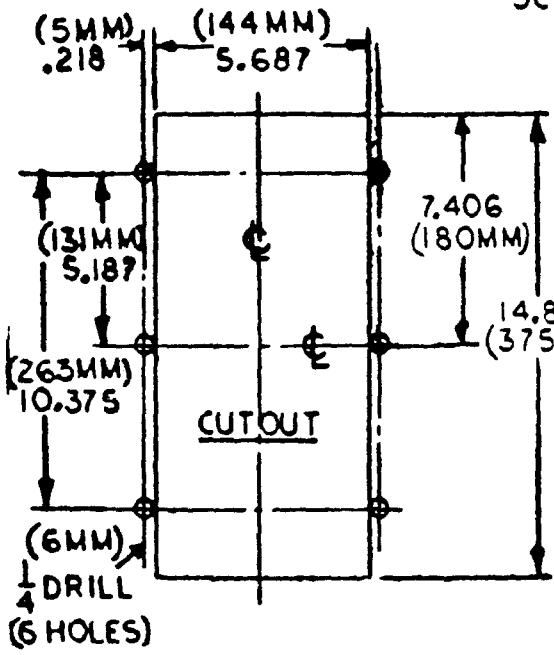
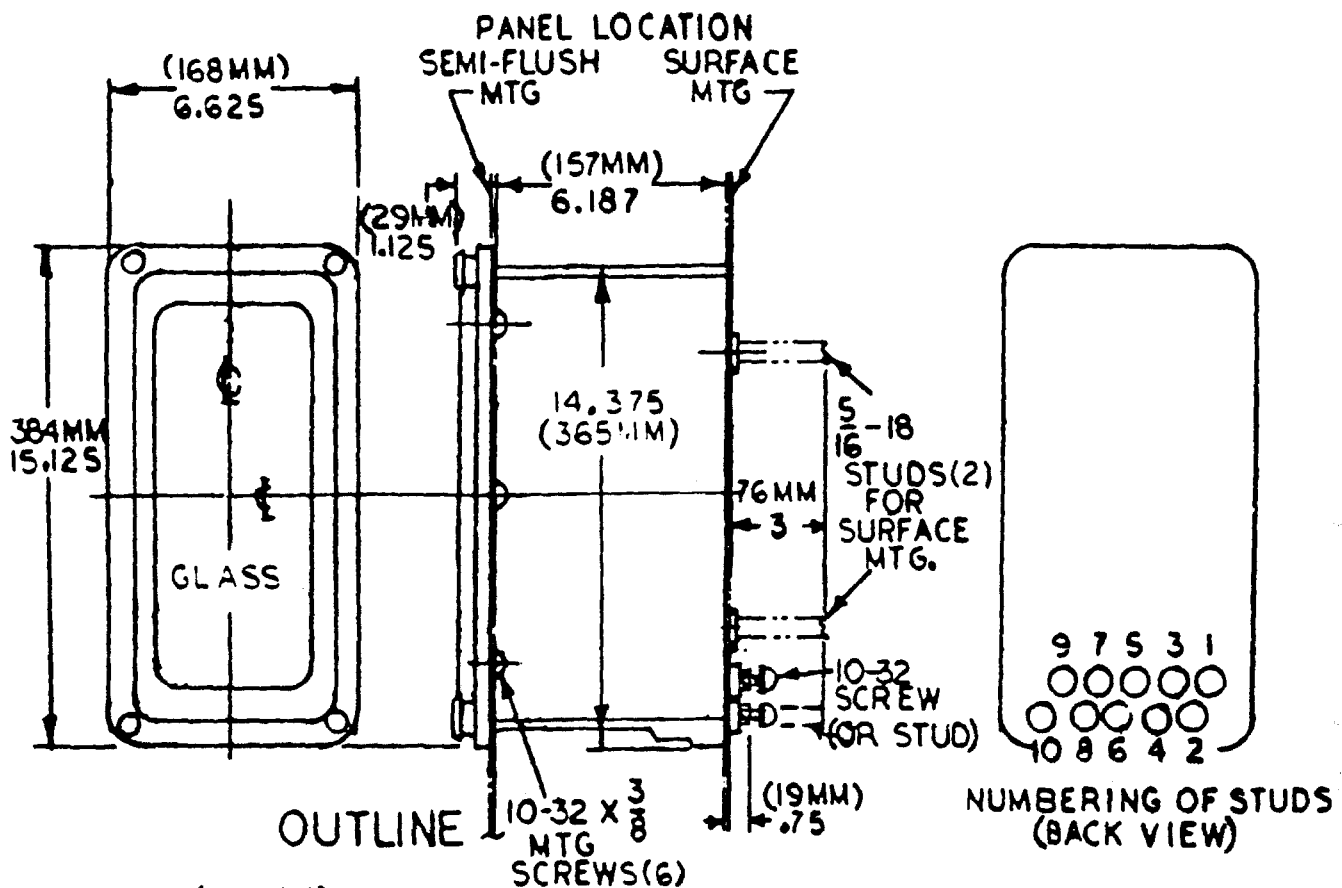

* FIG. 1 (K-6209273-3) Outline and Panel Drilling Dimensions for Type PVD Relays

* Indicates revision

DEVICE FUNCTION NUMBERS

- 87L - DIFFERENTIAL RELAY LOW SET UNIT
- 87H - DIFFERENTIAL RELAY HIGH SET UNIT
- 87S.1. - DIFFERENTIAL RELAY SEAL-IN UNIT

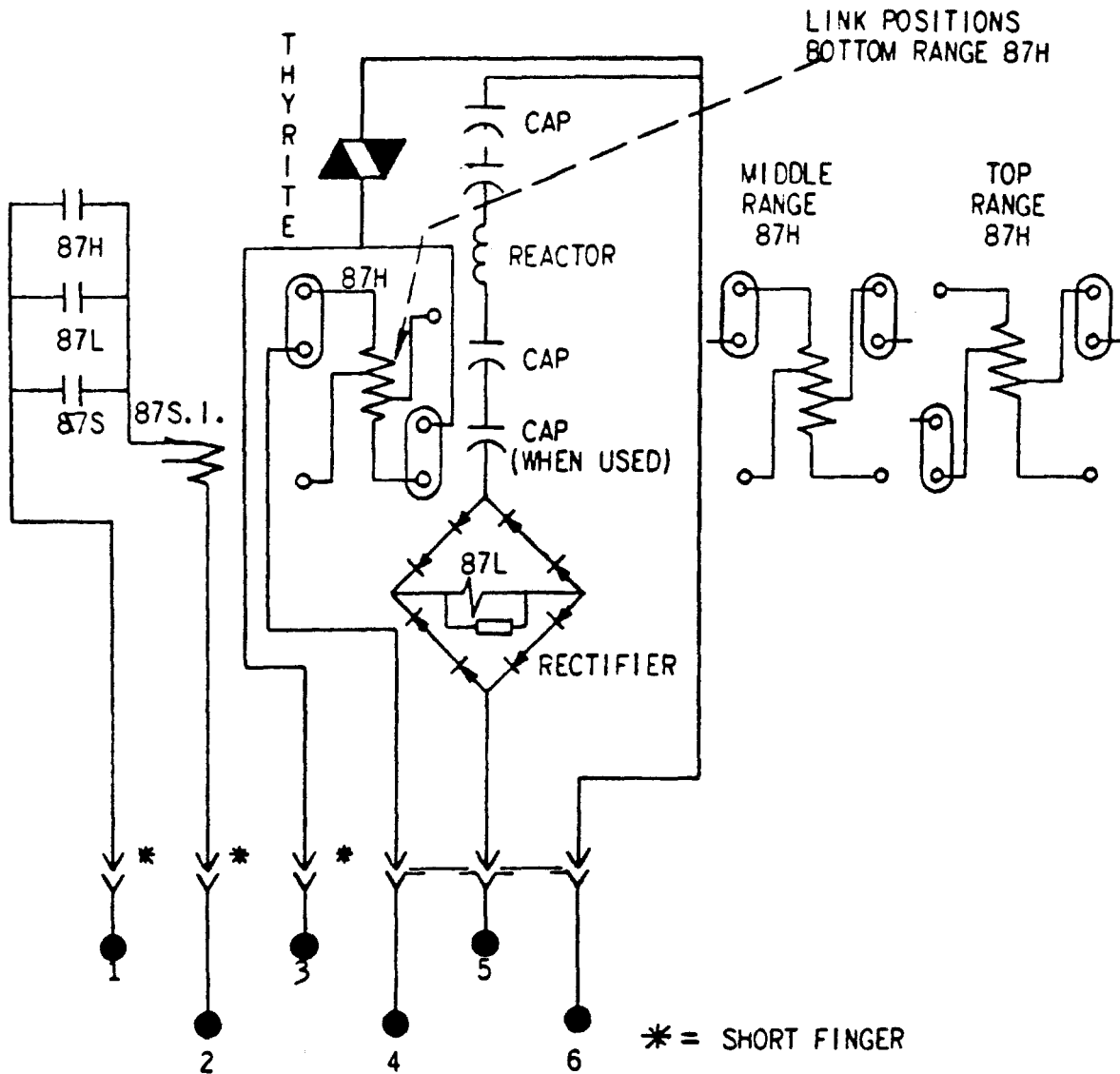

FIG. 2 (0208A2349-1) Internal Connections For Type PVD11C Relay (Front View)

LEGEND		
UNIT	TYPE	DESCRIPTION
07	PVD	STABLE POINT HIGH TEMPERATURE DIFFERENTIAL RELAY
	07A	LOW SET VOLTAGE UNIT
	07B	HIGH SET OVERCURRENT UNIT
	1 & 31	TARGET & SETPOINT UNIT
08	REL	RELAY RELAY

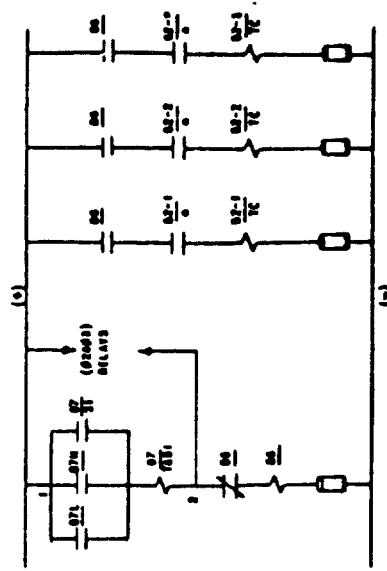
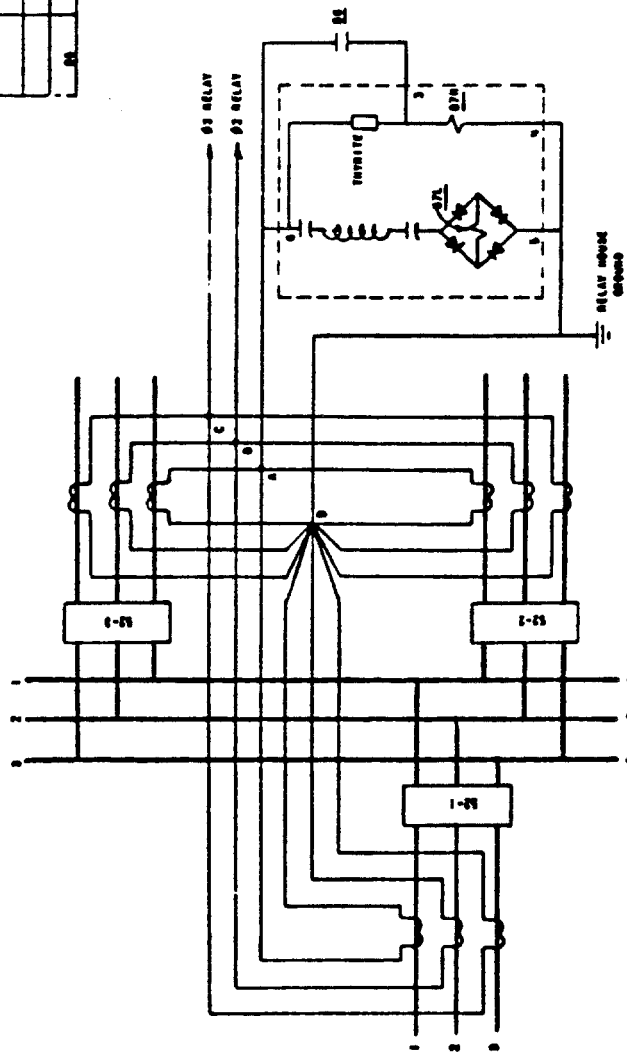

FIG. 4 (016582584-1) Typical External Connections For Type PVD11C And PVD11D Relays

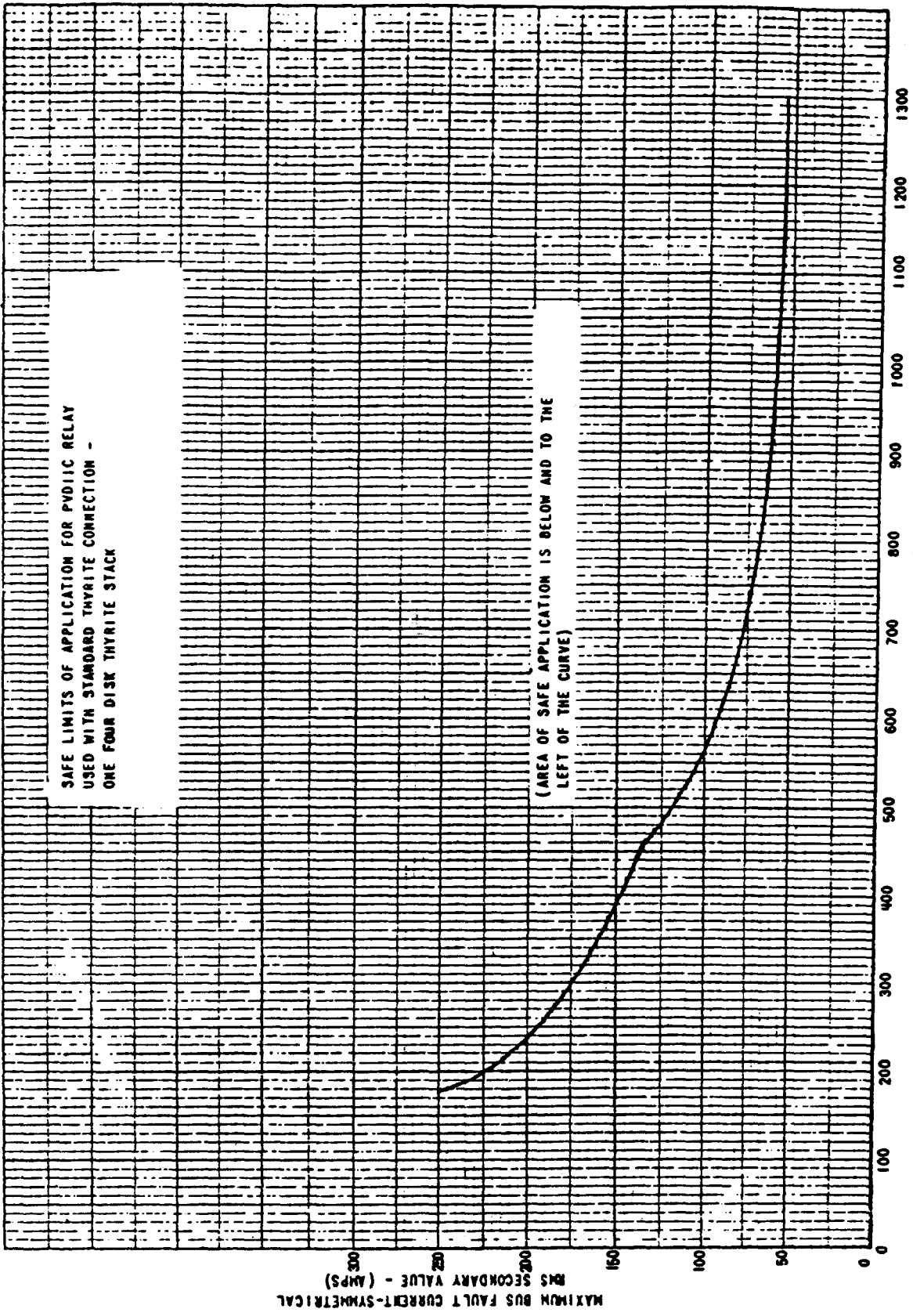

FIG. 5 (0246A3803-0) Safe Limits Of Application For PVD11C Relay With Standard Thyrite Connection - One Four Disk Thyrite Stack

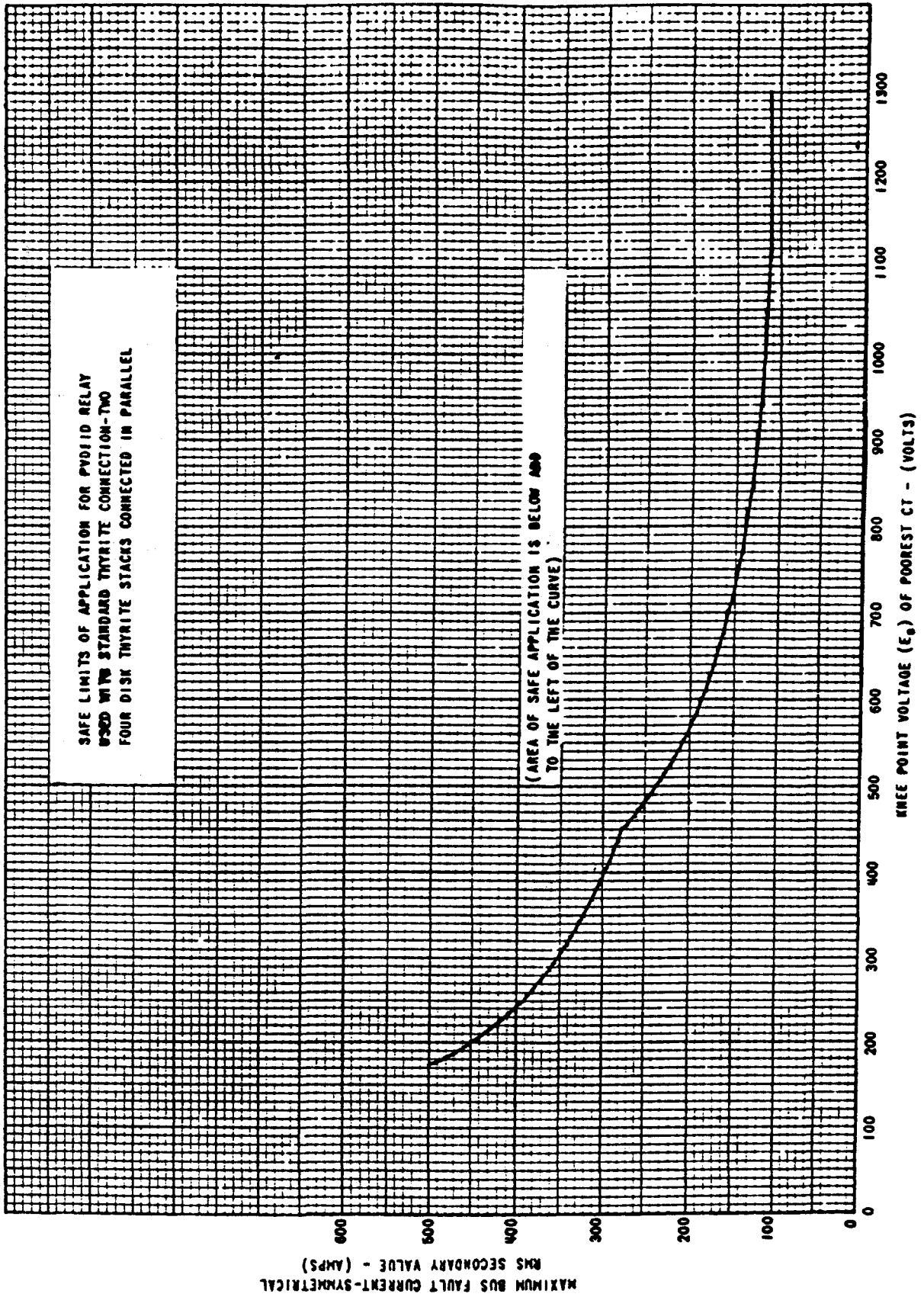

FIG. 6 (0246A3800-0) Safe Limits Of Application For PVD11D Relay With Standard Thyriste Connection - Two Four Disk Thyriste Stacks Connected In Parallel

CHARACTERISTIC CURVES

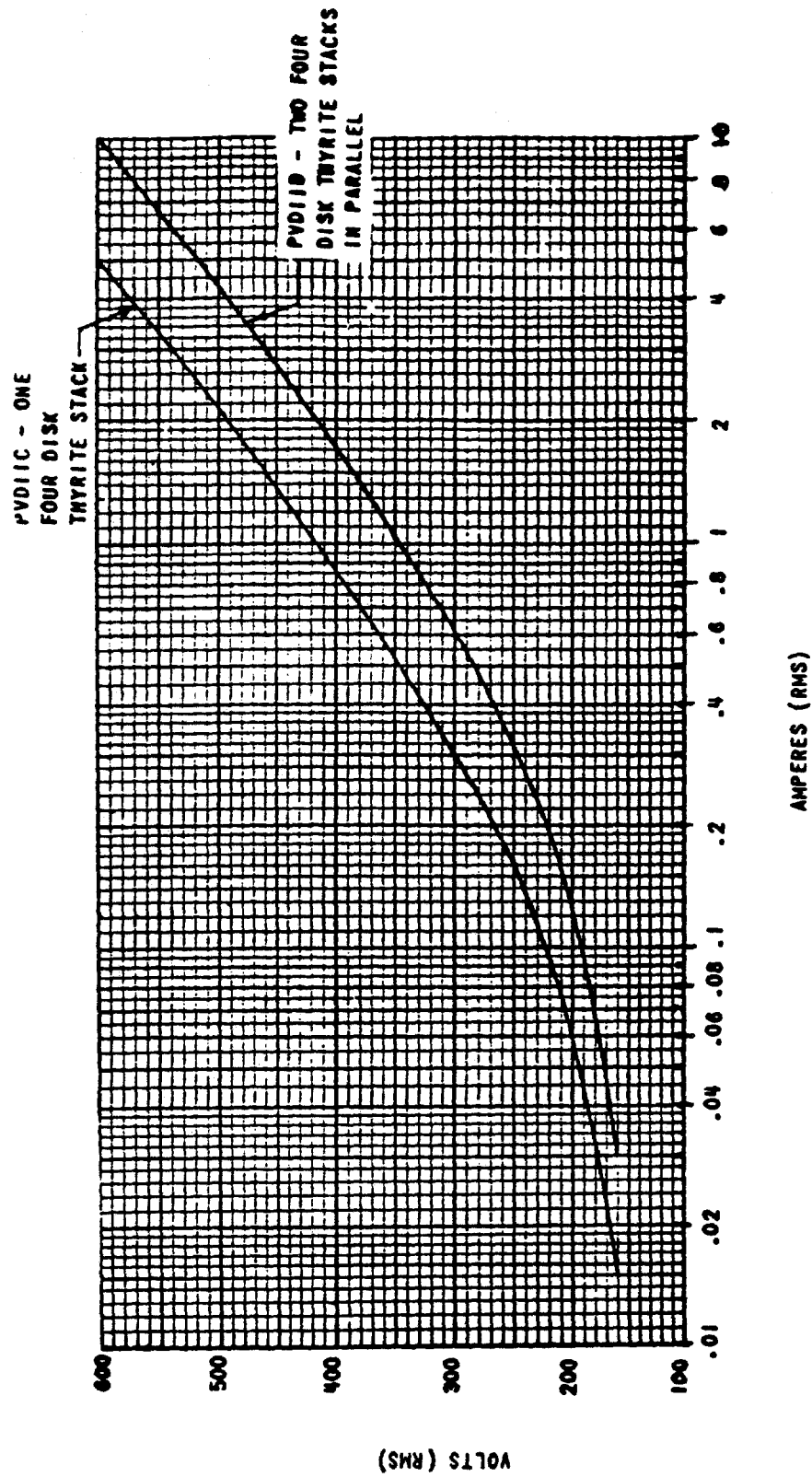

FIG. 7 (0246A3801-0) Thyrite Volt-Ampere Characteristics Of PVD11C And PVD11D Relays

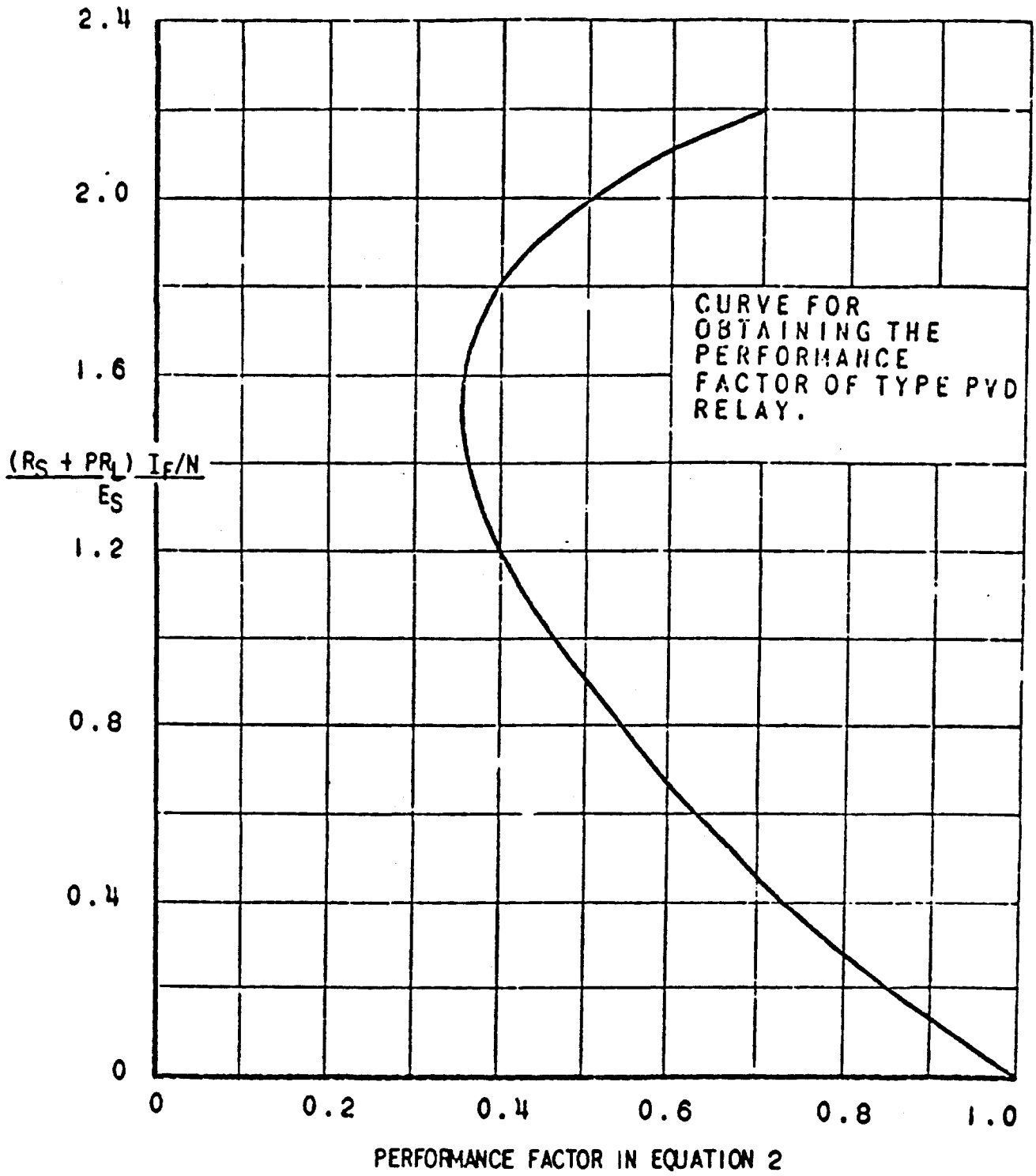

FIG. 8 (0246A3798-0) Curve Used To Obtain The Performance Factor Of The Type PVD Relay

CURVES FOR DETERMINATION OF 87H UNIT PICKUP SETTING
 (ABSCISSA SHOWS RMS AMPERES IN THYRISTE IF THE RMS
 SYMMETRICAL SINE WAVE VOLTS SHOWN ON THE ORDINATE
 WERE FULLY OFFSET)

SYMMETRICAL RMS VOLTS

$$2(R_S + PR_L) \frac{I_F}{N}$$

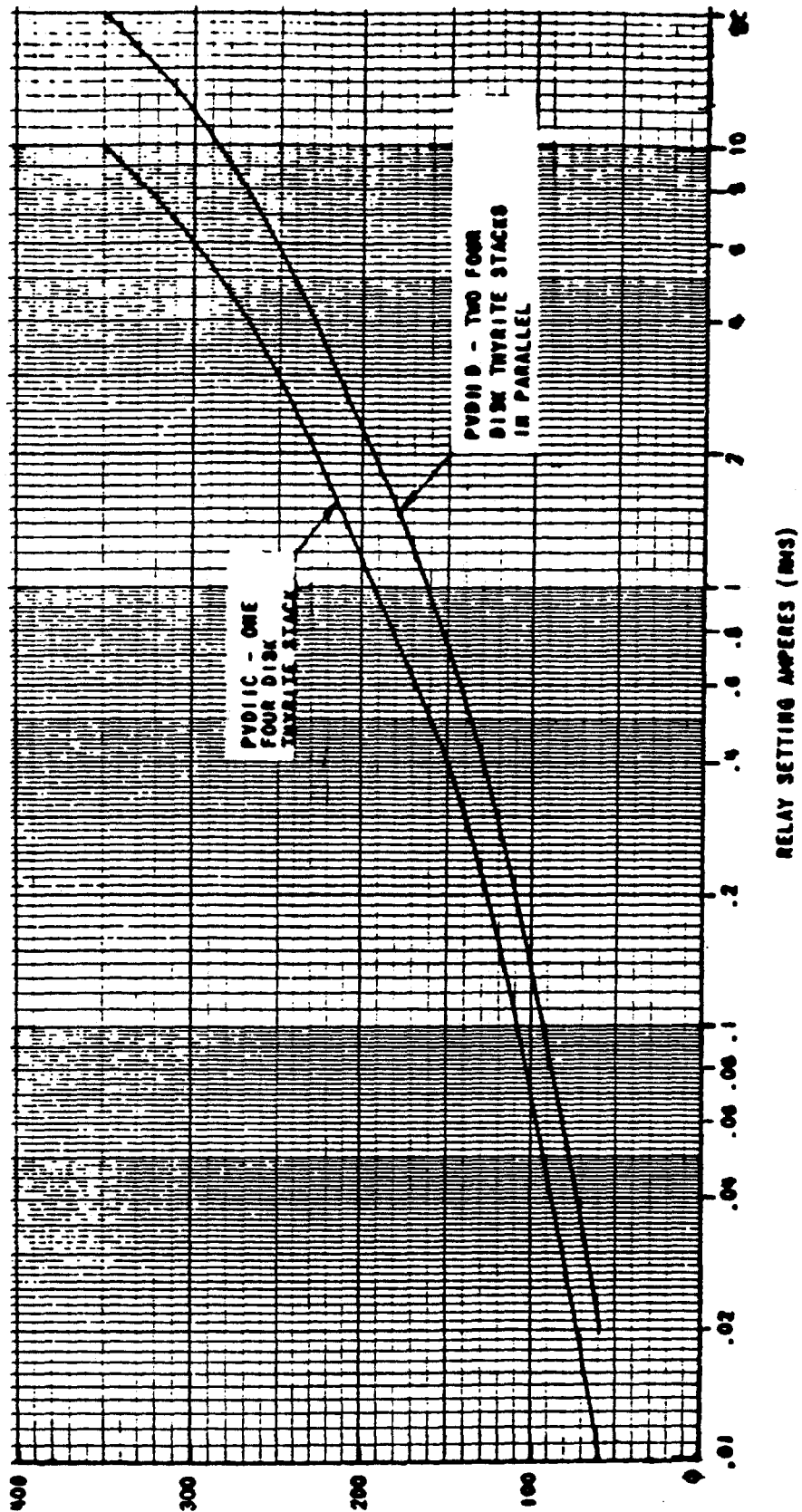

FIG. 9 (0246A3802-1) Curves Used For Obtaining 87H Unit Setting $2(R_S + PR_L) \frac{I_F}{N}$ Less Than 350 Volts

87H UNIT SETTING VS SECONDARY FAULT CURRENT FOR VARIOUS FAULT CT LOOP RESISTANCES. INDICATED SETTING IS FOR FULLY OFFSET SECONDARY CURRENT WHOSE SYMMETRICAL RMS VALUE WOULD BE AS SHOWN ON ORDINATE.

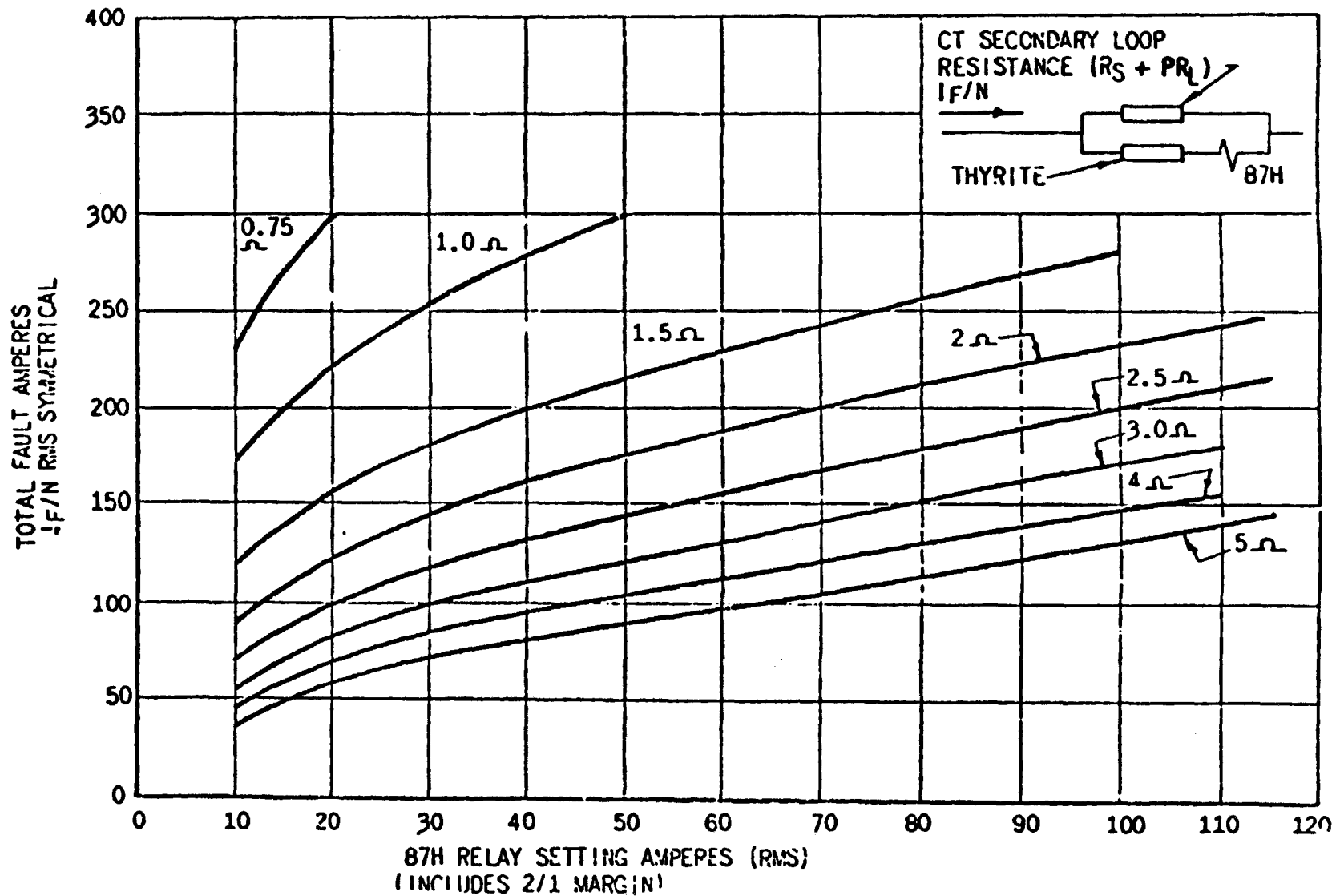

FIG. 10 (0246A3797-0) Curves Used for Obtaining 87H Unit Setting $2(R_s + P R_L) I_f / N$ Exceeds 350 Volts

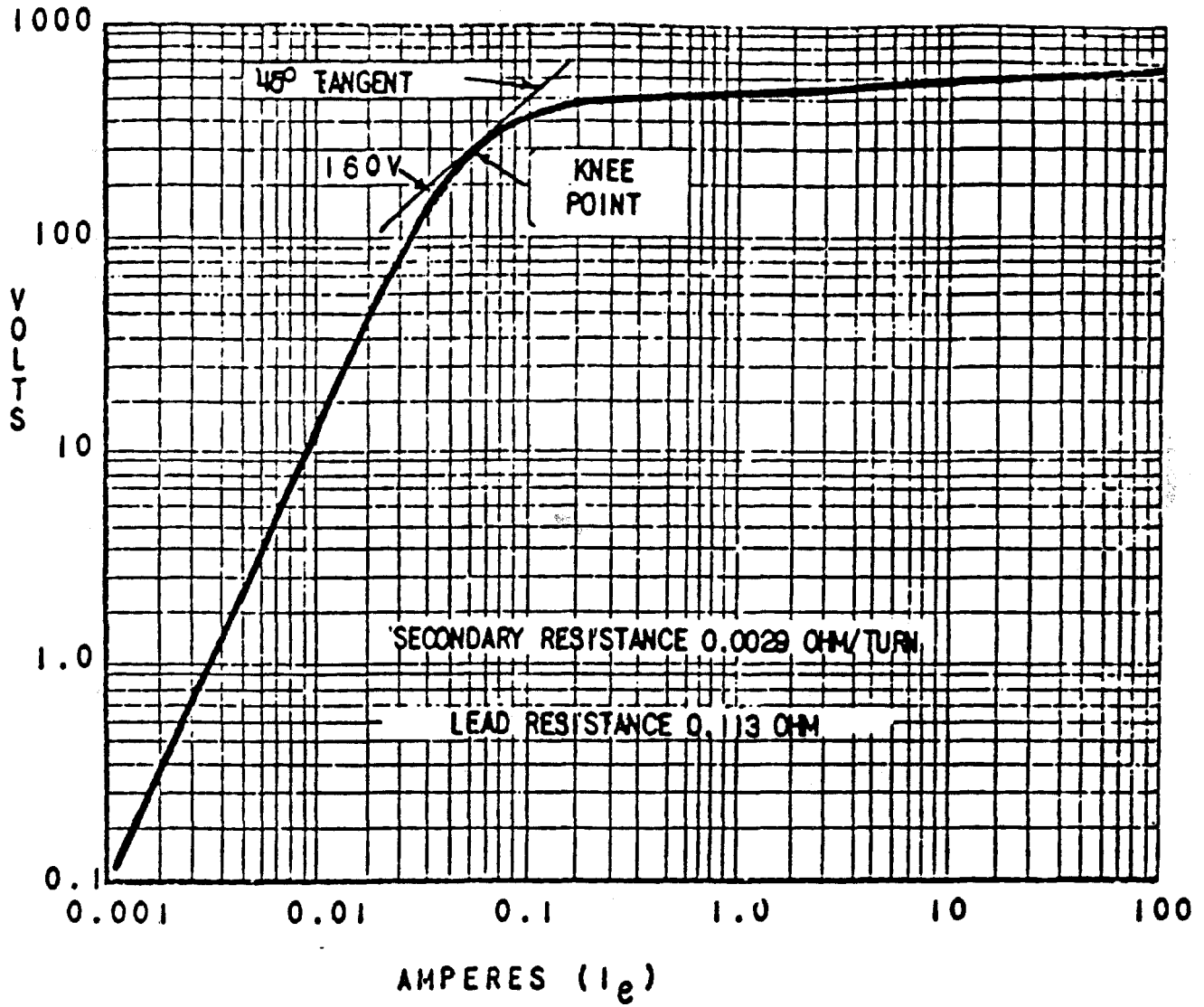
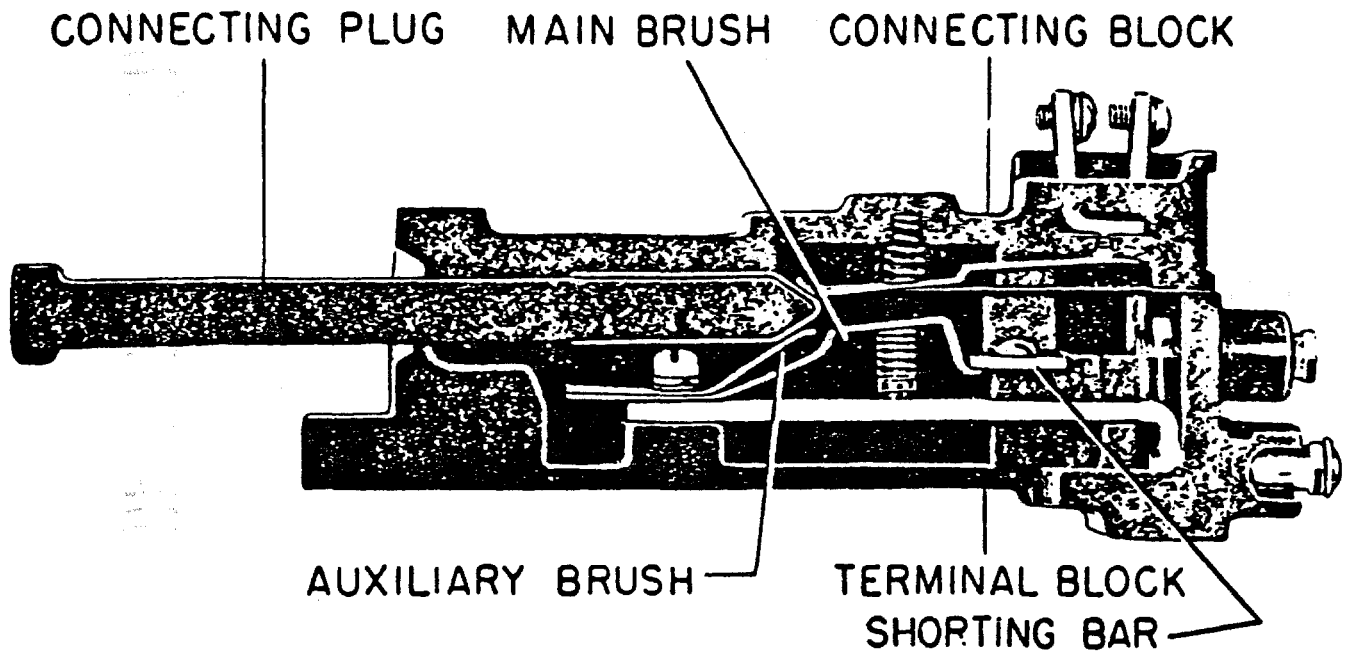

FIG. 11 (0246A3799-0) Typical Secondary Excitation Curve For Bushing Current Transformer



NOTE: AFTER ENGAGING AUXILIARY BRUSH, CONNECTING PLUG TRAVELS 1/4 INCH BEFORE ENGAGING THE MAIN BRUSH ON THE TERMINAL BLOCK

FIG. 12 (8025039) Cross Section Of Drawout Case Showing Position Of Auxiliary Brush And Shorting Bar

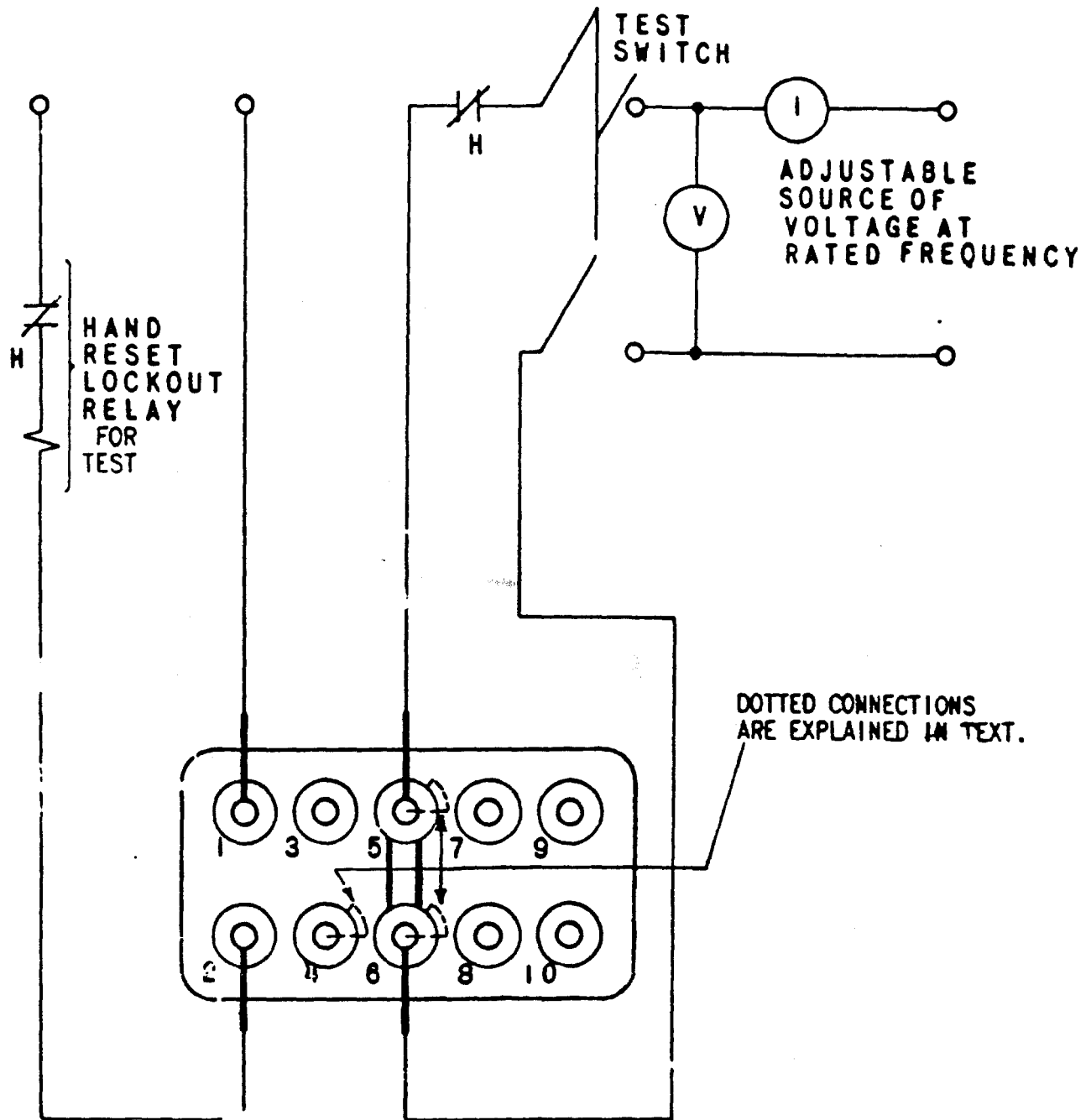

FIG. 13 (K-6507935-5) Test Connections For Type PVD11C And PVD11D Relays

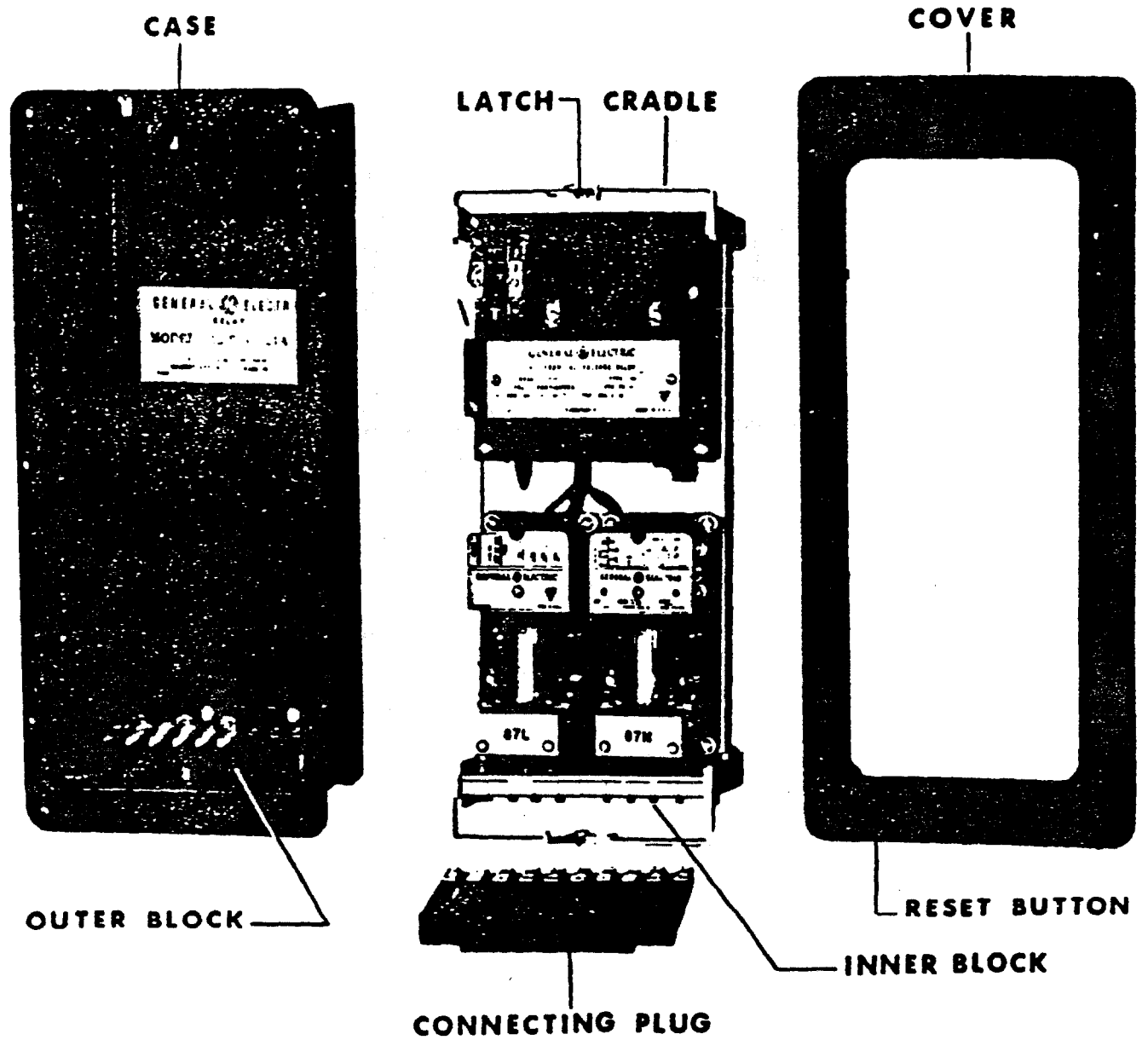

FIG. 14 (8009512) Type PVD11C Relay Disassembled

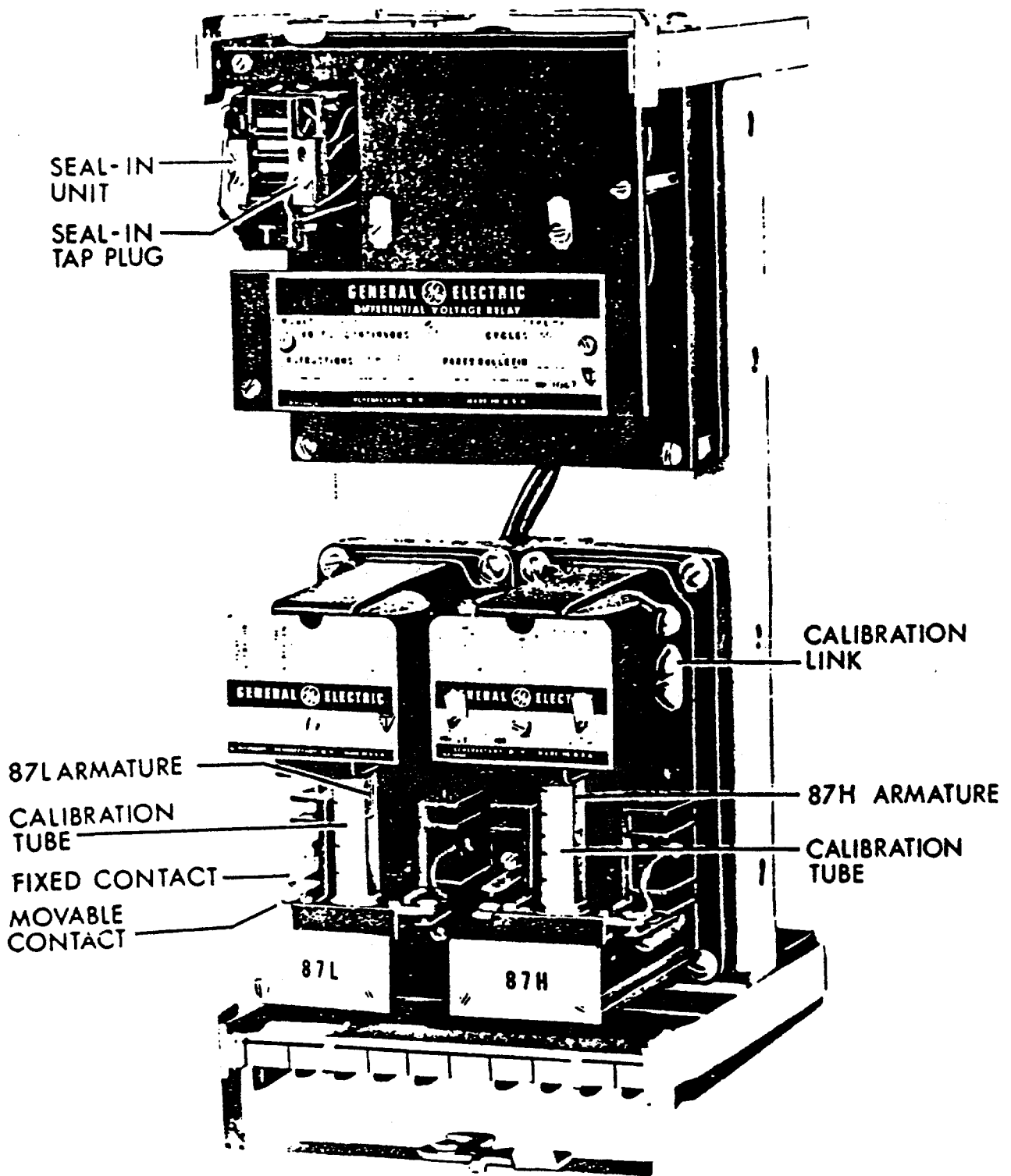

FIG. 15 (8018455) Type PVD11C Relay Unit In Cradle (Front View)

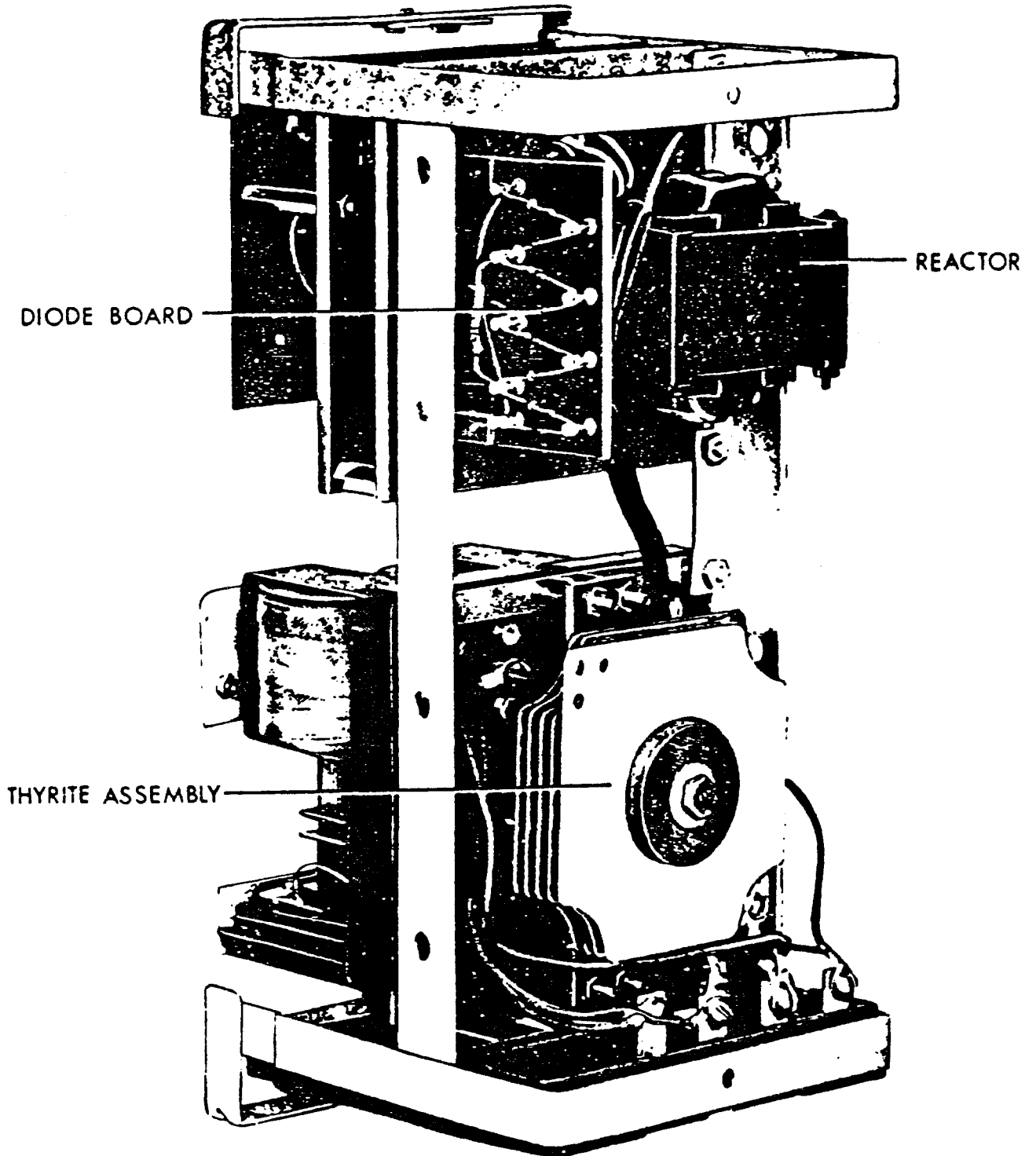

FIG. 16 (8041528) Type PVD11C Relay Unit In Cradle (Back View)



GE Power Management

215 Anderson Avenue
Markham, Ontario
Canada L6E 1B3
Tel: (905) 294-6222
Fax: (905) 201-2098
www.GEindustrial.com/pm