



Effective: September 1995  
Supersedes I.L. 41-751M, Dated August 1980  
( ) Denotes Change Since Previous Issue.



## Type SG Auxiliary Relay



Before putting protective relays into service, remove all blocking which may have been inserted for the purpose of securing the parts during shipment, make sure that all moving parts operate freely, inspect the contacts to see that they are clean and close properly, and operate the relay to check the settings and electrical connections.

### 1. APPLICATION

The relay is intended for use in the applications requiring:

- (1) Increased current-carrying or interrupting capability in a contact (low current contact energizes the SG coil to close the high current contact).
- (2) Circuit isolation.
- (3) Contact conversion (for example, from a normally open to a normally closed condition), or
- (4) Contact multiplication (from one contact input to two contact output).

The SG relay is available with 2 N.O. (normally-open) and 2 N.C. (normally-closed) contacts. They change condition when the coil is energized at a voltage level above pickup. The contacts are arranged in a 3-lead configuration with a "common" connected to a N.C. and a N.O. contact.

The relay can be supplied with suitable coils for use on the following voltages:

6, 12, 24, 48, 125 and 250 volts dc  
115 and 230 volts - 25 hertz  
115, 230, 440 and 575 volts - 50 or 60 hertz

By using a series resistor, each of the different voltage relays may be used on higher voltage systems provided the proper dielectric and safety considerations are observed.

### 2. CONSTRUCTION & OPERATION

The SG relays are clapper-type devices designed to operate over a wide range of ac and dc voltages. When their coils are energized at or above pickup rating, the moving contacts on the armature assembly, close and/or open with the two stationary contacts to activate the electrically independent contact circuits.

Closed types are supplied with two make and two break contacts. Open types (front connected) can be supplied with two make and two break contacts, or with only the two make contacts which can be reversed to provide one make, one break, or two break contact circuits. Contact gap and follow should be readjusted per Table 1 after contacts have been reversed. Adjustment is accomplished by bending the stationary contacts.

Small coil springs on the moving contact arms provide adequate contact pressure to assure positive contact action between the moving and stationary contacts.

Dc types have a bronze pin on the core which serves as a stop pin for the armature, and prevents magnetic seal-in of the armature due to residual magnetism. Ac types have a non-magnetic washer at the base of the core assembly to prevent the armature from sticking in the closed-gap position. Copper shading

*All possible contingencies which may arise during installation, operation or maintenance, and all details and variations of this equipment do not purport to be covered by these instructions. If further information is desired by purchaser regarding this particular installation, operation or maintenance of this equipment, the local ABB Power T&D Company Inc. representative should be contacted.*

rings are also provided on the core face of the ac types to prevent chattering of the armature.

### 3. CHARACTERISTICS

All relays will pick up at 80% of the nameplate voltage rating or less. No adjustments are provided for varying the pickup. The armature will open at 30% or less on direct current and at 60% or less on alternating current.

### 4. INSTALLATION

Mount the relay with the base against a vertical plane and with the contacts at the top.

When sheet metal cabinets are ordered for open-type relays, the relays and cabinets are shipped separately. The relays can be assembled on the tapped mounting holes in the bottom of the case by means of the mounting screws which are provided. The cabinets have knockouts for conduit connections on top, bottom and sides.

### 5. BURDEN

The closed gap volt-ampere burden at rated voltage (60 hertz) is 10, at a power factor of approximately 50%. The open gap volt-ampere burden at rated voltage (60 hertz) is 16, at the same power factor. The watt consumption at rated dc voltage is 3.5.

### 6. CONTACTS

Each contact will carry 12 amperes continuous and 30 amperes for one minute.

The contact interrupting ratings are as follows: All values are non-inductive currents.

#### INTERRUPTING RATING IN AMPERES

Volts	dc 1 Contact	2 Contacts in Series	ac 1 Contact
24	15	50	50
48	8	35	45
115	2.4	20	30
230	0.75	2.5	20
550	0.25	0.5	10

#### OPERATING TIME

Pickup: .033 - .05 sec. at dc rating  
.016 - .033 sec. at ac rating

Dropout: less than .016 sec. on dc or ac

### COIL DATA - DC

Rating amps	Volts	Resistance: Ohms	1 Second Rating: amps
1	-	2.5	35
2	-	0.7	55
3	-	0.33	85
4	-	0.2	110
5	-	0.1	185
-	5	12	-
-	12	48	-
-	24	185	-
-	32	294	-
-	48	725	-
-	62.5	1152	-
-	125	4650	-
-	250	17000	-

TABLE 1:  
CONTACT GAP AND FOLLOW ADJUSTMENT

Contact Arrange	Contact Gap	Make-Contact Follow
2M	5/32"	3/64"
2B	5/32"	-
SPDT	5/32"	3/64"
DPDT	1/8-9/64"	3/64"
Break Contact Follow		
	(1)	(2)
2M	-	-
2B	1/32-3/64"	0.020-0.031"
SPDT	3/64"	0.031"
DPDT	3/64"	0.031"

### 7. MAINTENANCE

All contacts should be cleaned periodically. A contact burnisher style 182A836H01 is recommended for this purpose. The use of abrasive material for cleaning contacts is not recommended, because of the danger of embedding small particles in the face of the soft silver and thus impairing the contact.

### 8. REPAIR AND RENEWAL PARTS

Major repairs can be most satisfactorily done at the factory or ABB Service Shops. However, for customers equipped to do their own work, parts may be furnished on order. In ordering any part or requesting any other information, always give entire nameplate data.

Relays for use on ac are assembled with a thin bronze washer between the yoke and core. A brass screw holds the yoke and core together. This washer helps to reduce the residual magnetism after the relay is de-energized. In case the relay should be dismantled, it is important that this washer be replaced when re-assembling it.

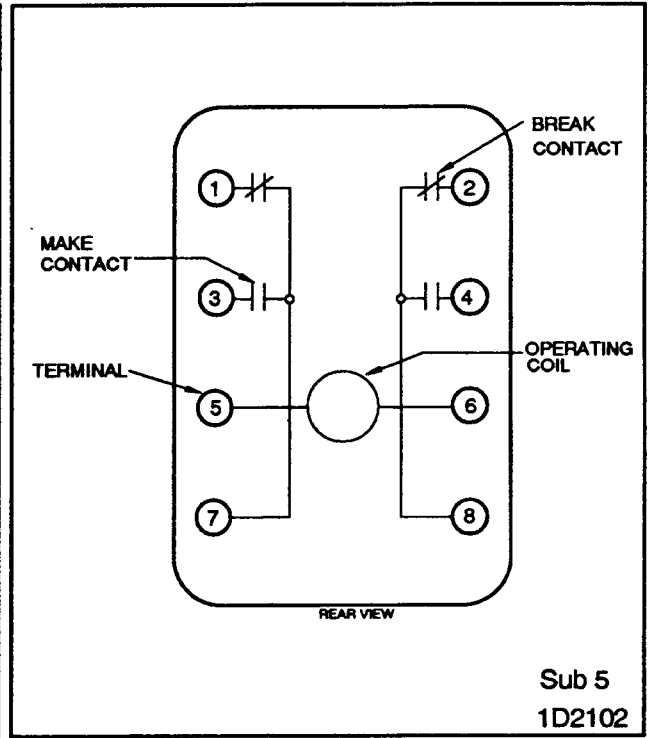
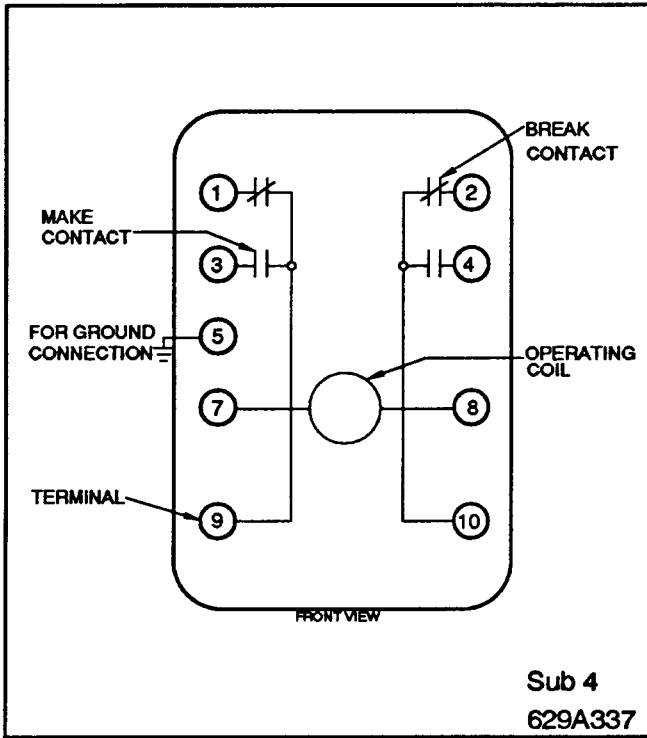

Figure 1. Internal Schematic for Type SG Relay in front connected case.

Figure 2. Internal Connections for Closed Type SG Relay.

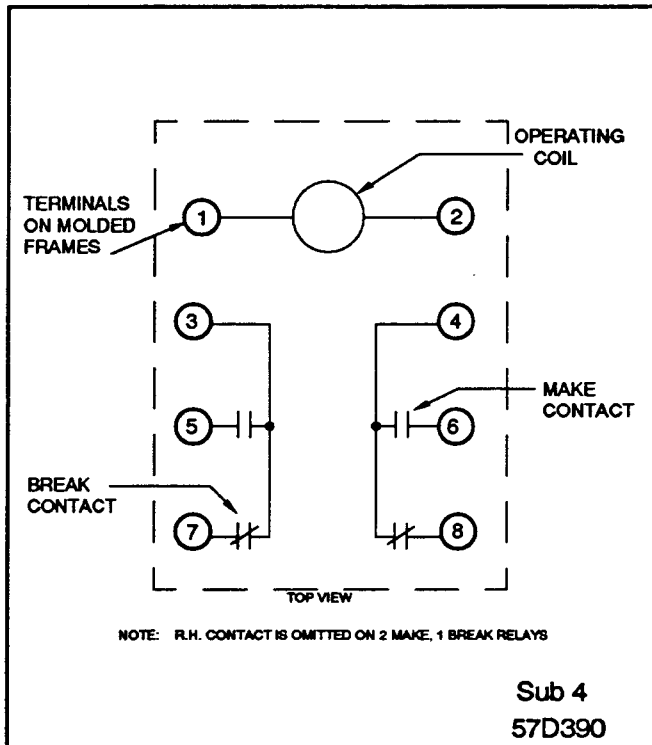

Figure 3. Internal Connections for 2-Make and 2-Break contact Open Type SG Relay.

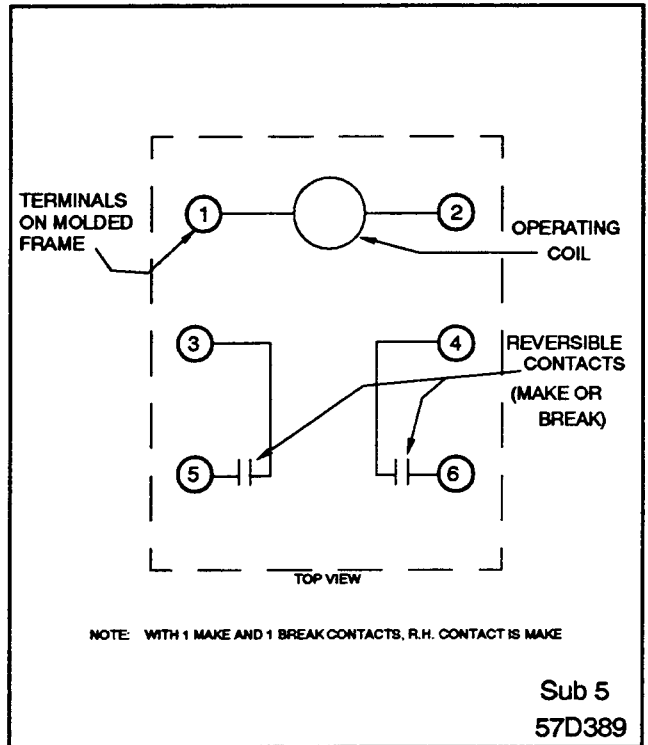

Figure 4. Internal Connections for Open Type SG Relay with Reversible Contacts.

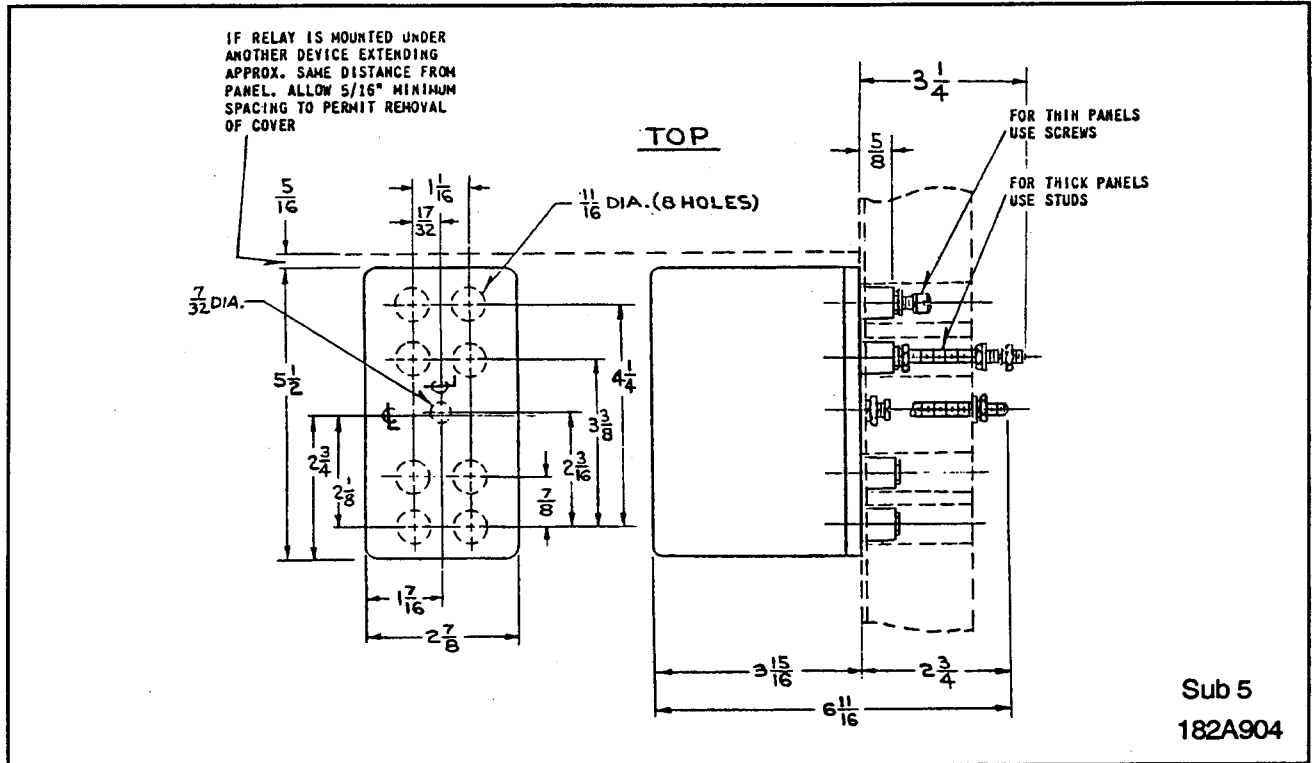

Figure 5. Outline and Drilling plan for the Closed Type SG Auxiliary Relay with 5/8 inch terminal studs.

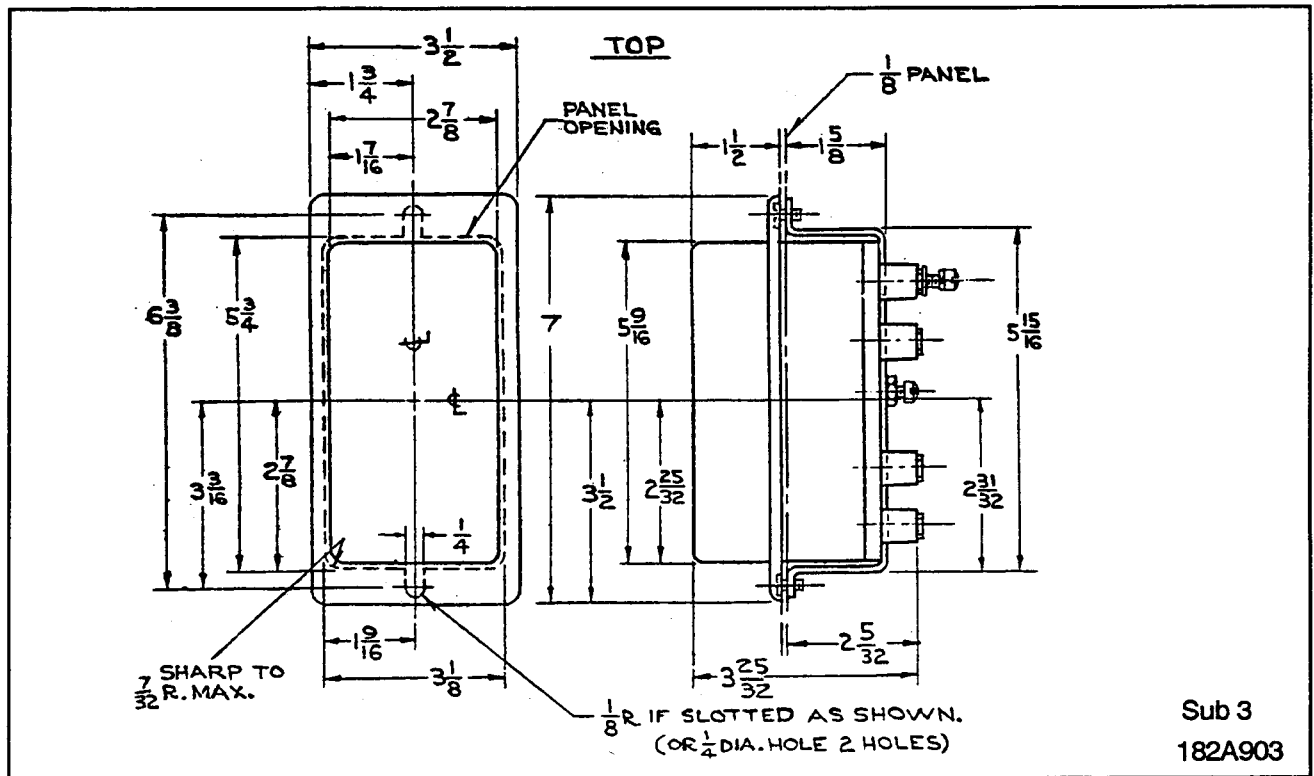

Figure 6. Outline and Drilling Plan for the Semi-flush Case for the Type SG Relay with 5/8 inch terminal studs.

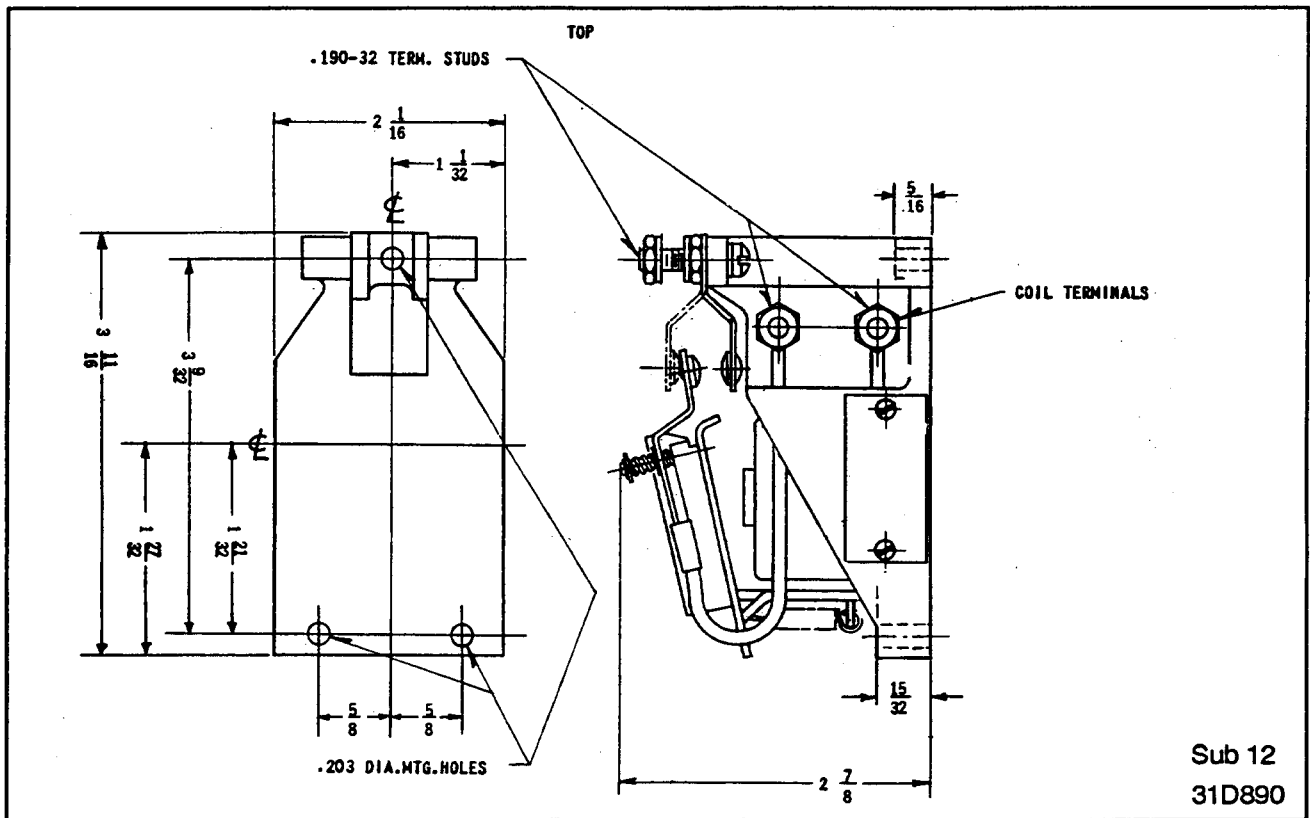

Figure 7. Outline and Drilling Plan for the Open Type SG Auxiliary Relay with Reversible Contacts.

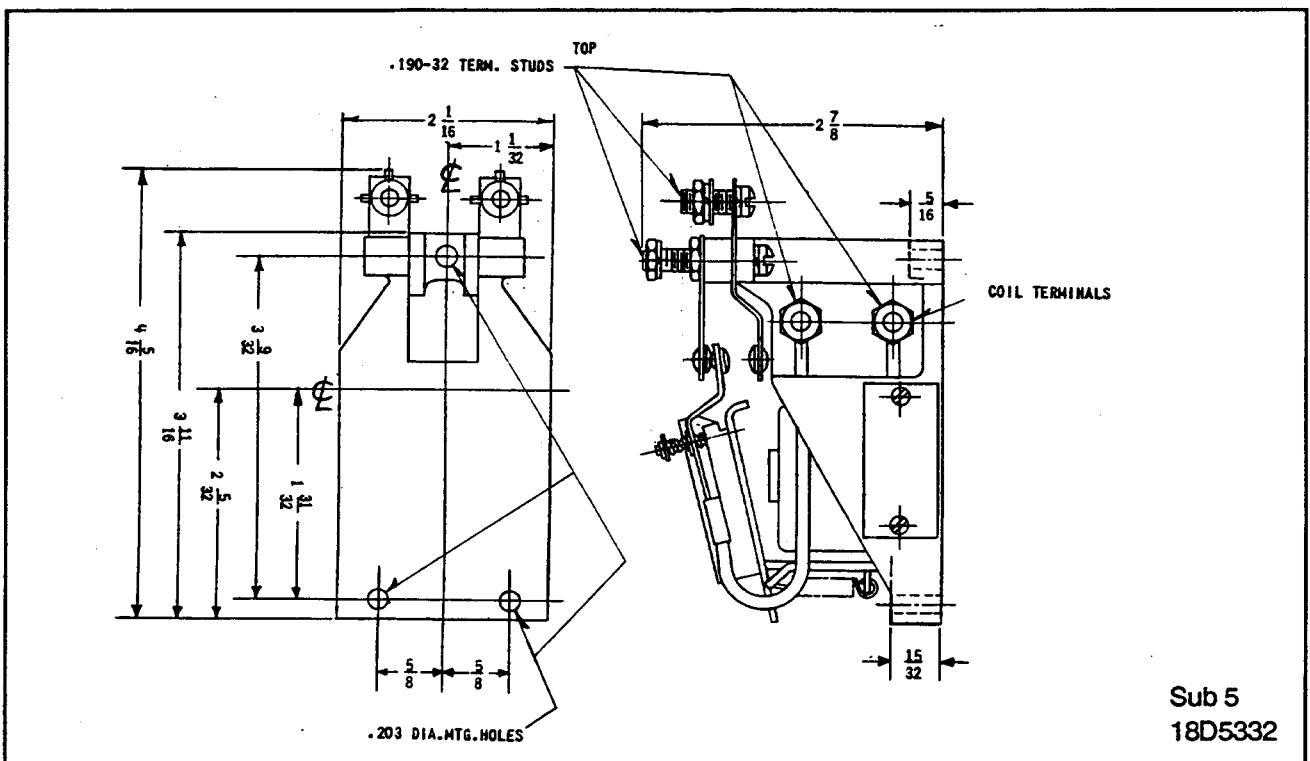

Figure 8. Outline and Drilling Plan for the 2-Make and 2-Break Contact Open Type SG Relay.

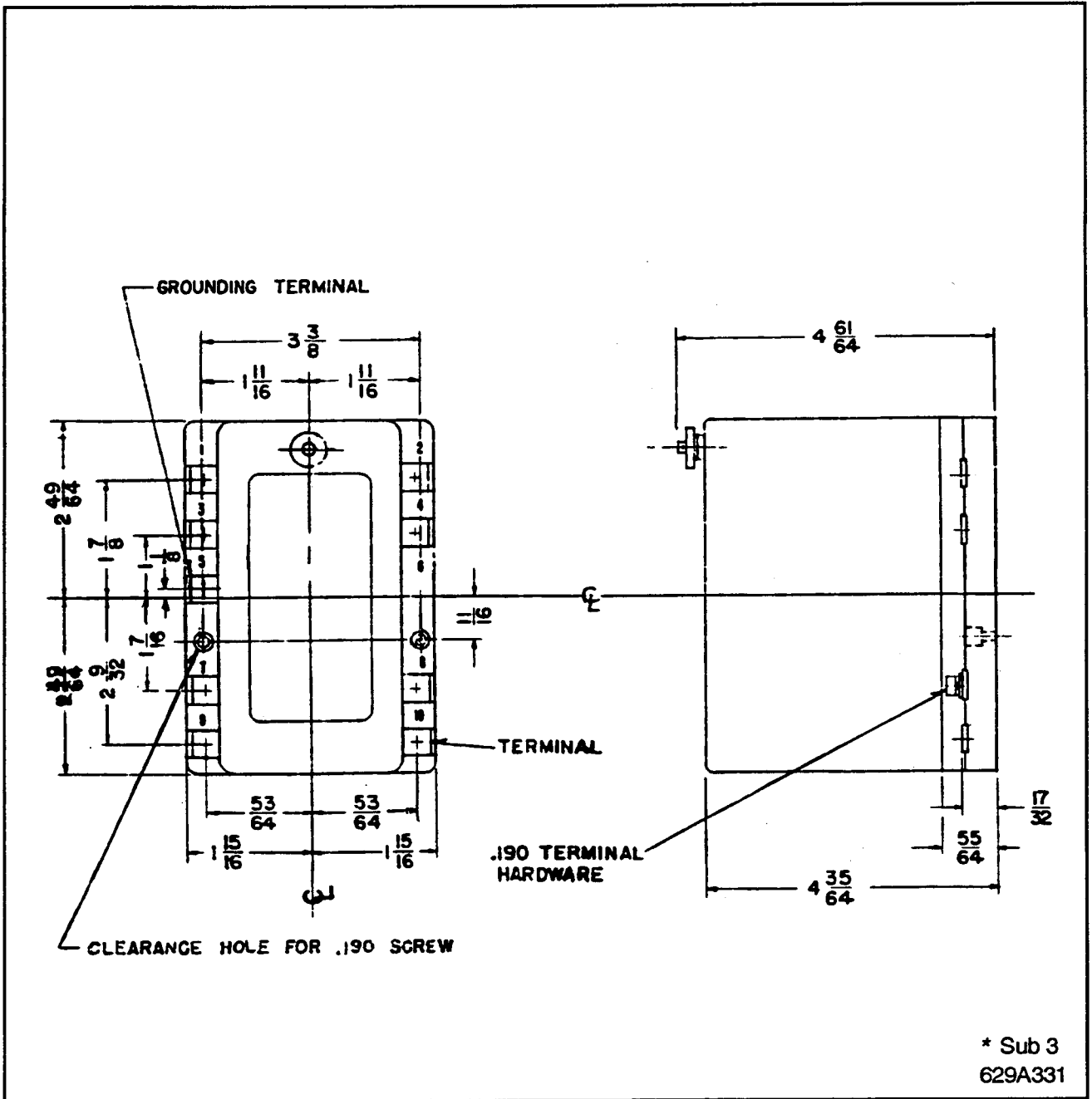

Figure 9. Outline and Drilling Plan for the Type SG Relay in Front Connected with dust cover.

\* Denotes Change