



Effective: January 1996
Supersedes 41-751.1F Dated October 1993
() Denotes Change Since Previous Issue

Type SG Auxiliary Relay in FT-11 and FT-22 Cases



File No. E103204



Before putting relays into service, remove all blocking which may have been inserted for the purpose of securing the parts during shipment, make sure that all moving parts operate freely, inspect the contacts to see that they are clean and close properly, and operate the relay to check the settings and electrical connections.

1. APPLICATION

The relay is intended for use in the applications requiring:

- (1) Increased current-carrying or interrupting capability in a contact (low current contact energizes the SG coil to close the high current contact).
- (2) Circuit isolation.
- (3) Contact conversion (for example, from a normally open to a normally closed condition), or
- (4) Contact multiplication (from one contact input to two contact output).

The SG relay has 2 N.O. (normally-open) and 2 N.C. (normally-closed) contacts. They change condition when the coil is energized at a voltage level above pickup. The contacts are arranged in a 3-lead configuration with a "common" connected to a N.C. and a N.O. contact.

The relay can be supplied with suitable coils for use on the following voltages:

6, 12, 24, 48, 125 and 250 volts dc
115 and 230 volts - 25 hertz
115, 230, 440 and 575 volts - 50 or 60 hertz

By using a series resistor, each of the different voltage relays may be used on higher voltage systems provided the proper dielectric and safety considerations are observed.

2. CONSTRUCTION

The SG relays are clapper-type devices designed to operate over a wide range of ac and dc voltages. When their coils are energized at or above pickup rating, the moving contacts on the armature assembly, close and/or open with the two stationary contacts to activate the electrically independent contact circuits.

Small coil springs on the moving contact arms provide adequate contact pressure to assure positive contact action between the moving and stationary contacts.

Dc types have a bronze pin on the core which serves as a stop pin for the armature, and prevents magnetic seal-in of the armature due to residual magnetism. Ac types have a non-magnetic washer at the base of the core assembly to prevent the armature from sticking in the closed-gap position. Copper shading rings are also provided on the core face of the ac types to prevent chattering of the armature.

The assembly of the moving contact fingers on the armature block is arranged to provide spring follow on both the make and break contacts. The stationary contact bracket may be bent slightly, if

All possible contingencies which may arise during installation, operation or maintenance, and all details and variations of this equipment do not purport to be covered by these instructions. If further information is desired by purchaser regarding this particular installation, operation or maintenance of this equipment, the local ABB Power T&D Company Inc. representative should be contacted.

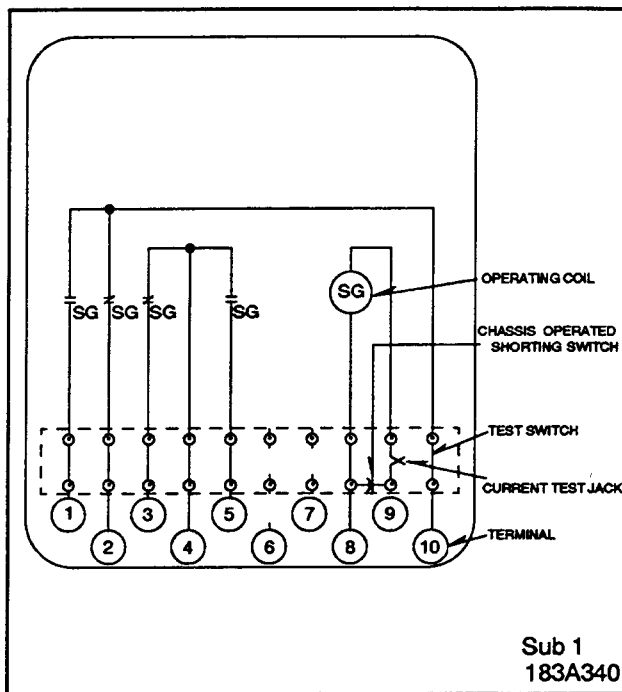

Figure 1. Internal Schematic of the Single Unit SG Relay, with Current Operated Coil, in FT-11 Case. Shorting Switches and Current Test jack Omitted from Terminals 8 and 9 for Voltage Operated Relays.

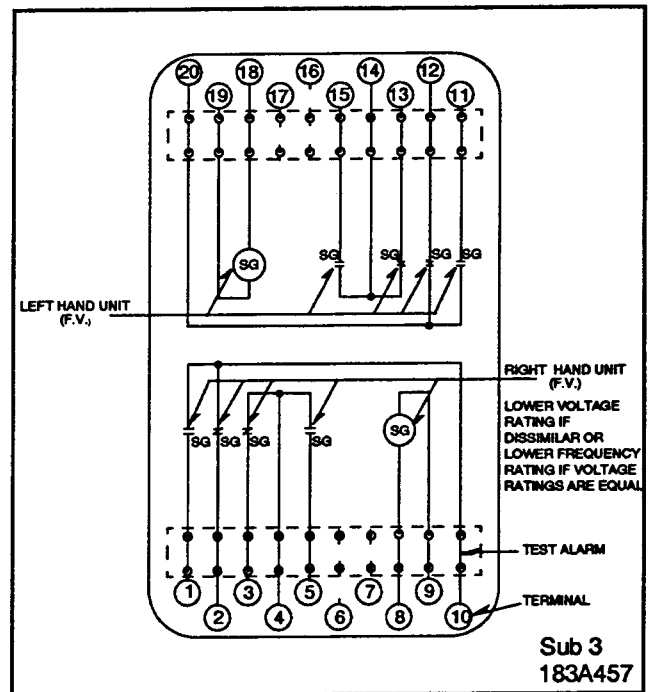

Figure 2. Internal Schematic of the Double Unit SG Relay, voltage Operated Coils, in FT-22 Case.

necessary, to change the back contact follow or alignment. See Table I for proper contact adjustment.

3. INSTALLATION

The relays should be mounted on switchboard panels or their equivalent in a location free of dirt moisture, excessive vibration, and heat. Mount the relay vertically by means of the four mounting holes on the flange for semi-flush mounting or by means of the rear mounting stud or studs for projection mounting. Either a mounting stud or the mounting screws may be utilized for grounding the relay. The electrical connections may be made directly to the terminals by means of screws for steel panel mounting or to the terminal studs furnished with the relay for thick panel mounting. The terminal studs may easily be removed or inserted by locking two nuts on the stud and then turning the proper nuts with a wrench.

For detailed FT case information, refer to the I.L. 41-076.

4. CHARACTERISTICS

All relays will pick up at 80% of the nameplate voltage rating or less. No adjustments are provided for vary-

ing the pick-up. The armature will open at 30% or less with direct current and at 60% or less with alternating current.

The at rated voltage (60 Hertz) is 10, at a power factor of approximately 50%. The watt consumption at rated dc voltage is 3.5 watts.

Each contact will carry 12 amperes continuous and 30 amperes for one minute.

The contact interrupting ratings that follow are non-inductive currents. External connections may be made for contacts in series if desired.1

Interrupting Rating in Amperes

Volts	dc Amps 1 Contact	dc Amps 2 Contacts In Series	ac amps 1 Contact
24	15	50	50
48	8	35	45
115	2.4	20	30
230	0.75	2.5	20
550	0.25	0.5	10

4.1 Operating Time

Pickup: .033 - .05 sec. at dc rating
 .016-.033 sec. at ac rating
 Drop-out: less than .016 sec. at dc or ac rating

5. ADJUSTMENTS AND MAINTENANCE

Contact gaps and follow adjustments can be made per Table1.

Table 1:
Adjustments and Maintenance

Contact Arrangement	Contact Gap	Make Contact Follow	Break Contact Follow	
			(1)	(2)
DPDT	1/8 - 9/64"	3/64"	3/64"	0.031"

- (1) Measured at the contacts
- (2) Measured between the contact finger and the guide bushing shoulder.

6. MAINTENANCE AND RENEWAL PARTS

All contacts should be cleaned periodically. A contact burnisher Style 182A836H01 is recommended for this purpose. The use of abrasive material for cleaning contacts is not recommended, because of the danger of embedding small particles in the face of the soft silver and thus impairing the contact.

Major repairs can be most satisfactorily done at the factory. However, for customers equipped to do their own work, parts may be furnished on order. In ordering any part or requesting any information, always give entire nameplate information.

Relays for use on ac are assembled with a thin bronze washer between the yoke and core. A brass screw holds the yoke and core together. This washer helps to reduce the residual magnetism after the relay is de-energized. In case the relay should be dismantled, it is important that this washer be replaced when reassembling it.

ABB Power T&D Company Inc.
 4300 Coral Ridge Drive
 Coral Springs Florida 33065
 (954) 752-6700
 FAX: (954) 345-5329

ABB Network Partner

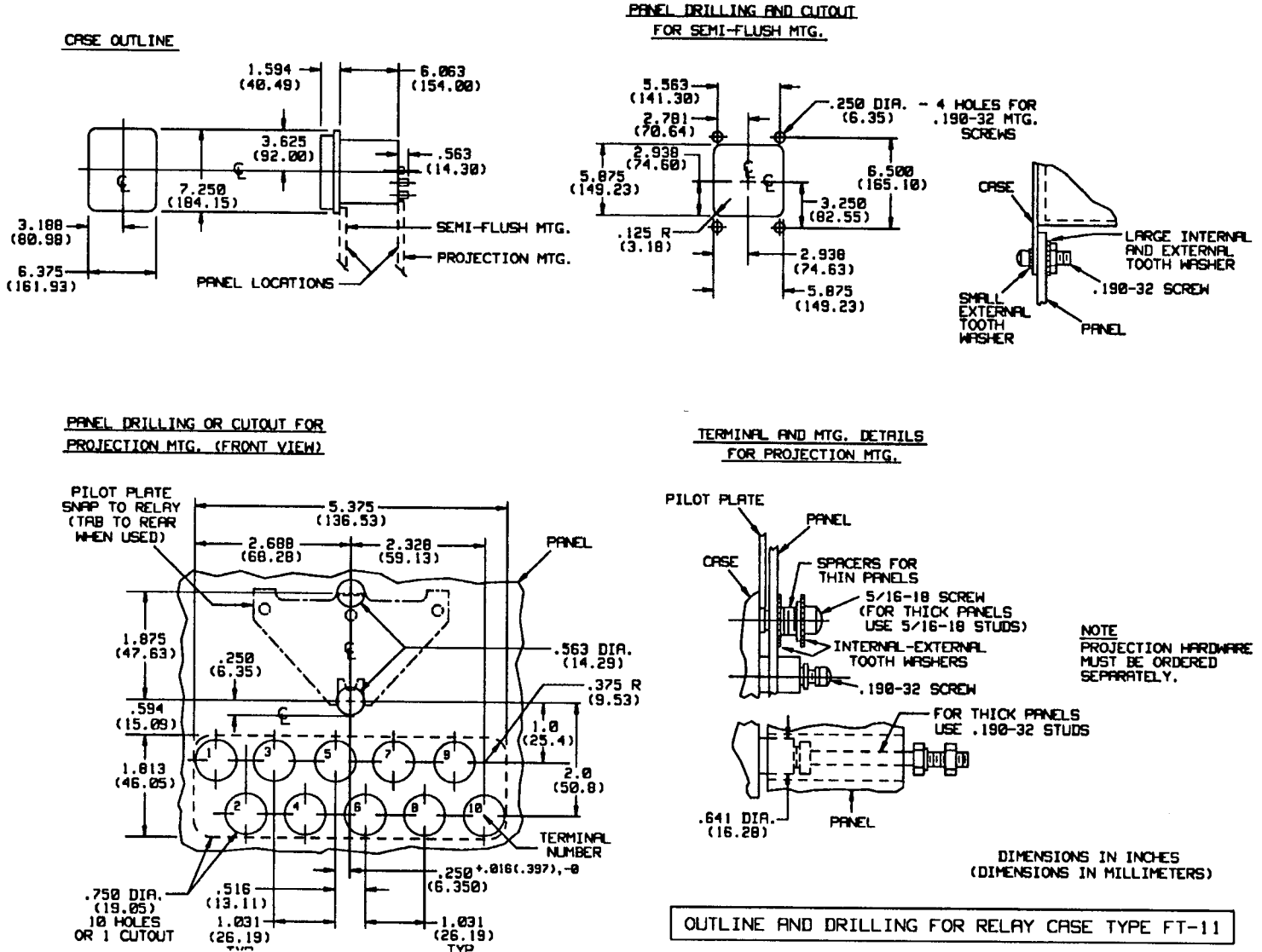

Figure 3. Outline and Drilling Plan for the Single Unit SG Relay in FT-11 Case

* Sub 19

57D7900