



## Type TD-5 Time Delay Relay

Effective September 1980  
Supersedes I.L. 41-579.1M dated March 1980

\* Denotes change since previous issue

**CAUTION:** Before putting relays into service, operate the relay to check the electrical connections. Close the red handle switch last when placing the relay in service. Open the red handle switch first when removing the relay from service.

### ⊕ APPLICATION

The type TD-5 relay is used in timing applications where accuracy, repeatability and fast reset are required. Its principal use is in time delayed distance relaying and in breaker failure timing applications.

It is a dc relay capable of direct application to station batteries. It covers 0.05 to 30 seconds in 4 different ranges. For dual independent timing refer to TD-52 relay, I.L. 41-579.3.

### CONSTRUCTION

The type TD-5 relay consists of a reference voltage circuit, a rheostat (T) and scale plate, a voltage biasing potentiometer (P), a printed circuit containing static timing components, an output telephone relay (TR), and an indicating contactor switch (ICS). An auxiliary relay (TX) is supplied on some types to override bounce of the initiating contact.

#### Reference Voltage Circuits

The reference voltage circuit provides a fixed supply voltage to the R-C time delay circuit and protects the static components from high voltages. It consists of a silicon power regulator and a series

resistor (Rs). The silicon power regulator (Z) is a 10 watt Zener diode mounted on an aluminum heat sink. The series resistor (Rs) is a 3½ inch resistor which is tapped for 24/32 volt dc and 48/125 volt dc relays.

#### Rheostat and Scale Plate

The rheostat (T) provides a variable resistance for the R-C time delay circuit. It is of wire-wound construction, which minimizes resistance change with temperature. Do not remove the knob from the rheostat shaft, since it is not easy to replace the knob in the calibrated position. The timing scale is non-linear as explained in the section under Printed Circuit.

#### Potentiometer

The potentiometer (P), provides a biasing voltage which keeps the silicon controlled rectifier (SCR) turned off until the capacitor voltage reaches the potentiometer brush voltage. It is of wire-wound construction and has a locking nut which should not be loosened unless the relay is being re-calibrated.

#### Printed Circuit

The printed circuit contains a diode (D<sub>1</sub>) which protects the static components in case the relay is connected with reverse polarity, a limiting timing resistor (R<sub>L</sub>), timing capacitor (C), a parallel resistor (R<sub>p</sub>) which makes the calibrating scale non-linear, and a silicon controlled rectifier (SCR). The printed circuit also contains a diode (D<sub>2</sub>) to reverse bias

*All possible contingencies which may arise during installation, operation, or maintenance, and all details and variations of this equipment do not purport to be covered by these instructions. If further information is desired by purchaser regarding this particular installation, operation or maintenance of this equipment, the local Asea Brown Boveri representative should be contacted.*

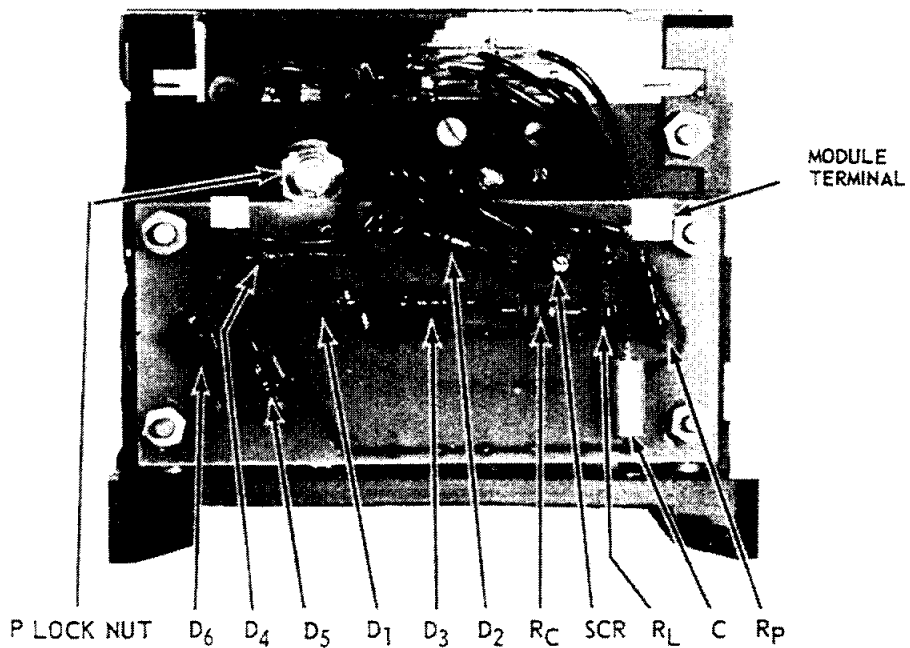
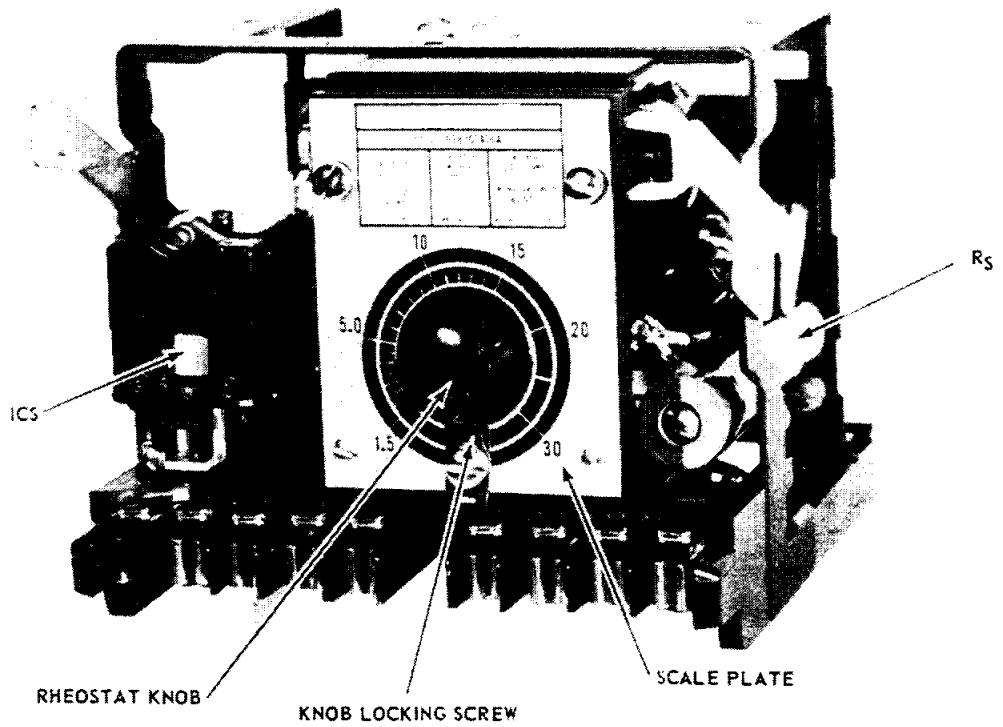

Fig. 1. Type TD-5 Relay Without Case.

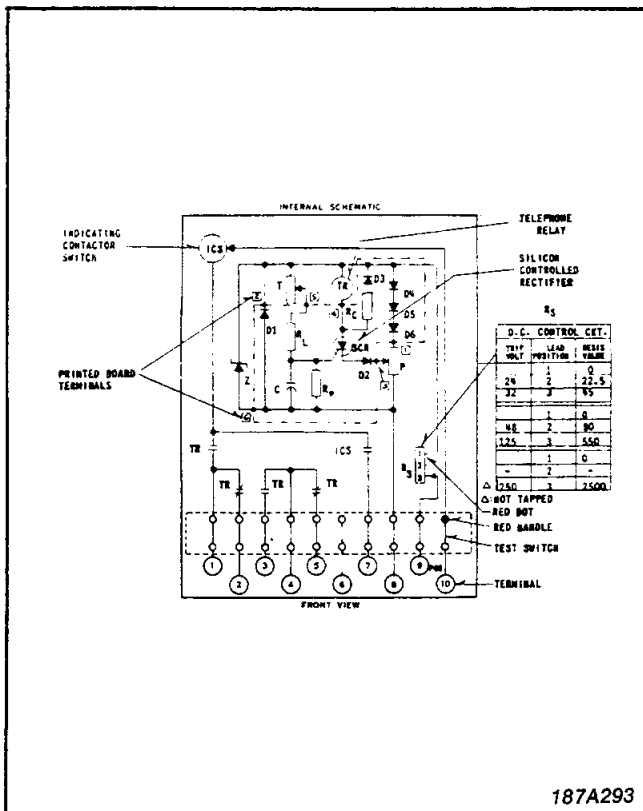

Fig. 2. Internal Schematic of Type TD-5 Relay.

SCR, a resistor ( $R_C$ ) and diode ( $D_3$ ) to protect the static components from the inductive voltage kick associated with the telephone relay coil, and series diodes ( $D_4$ ,  $D_5$ , and  $D_6$ ) which compensate for the forward voltage drop through SCR and  $D_2$  and zener reference variations.

### Telephone Relay (TR)

The telephone relay (TR) is energized by SCR at the conclusion of the time delay. The coil is energized by at least three times pick-up wattage to insure positive contact operation. The contacts are made of palladium and are suitable for circuit breaker trip duty, as proven by many years of experience in other relays. Two sets of transfer contacts are provided to give a flexible trip circuit arrangement.

### Telephone Relay (TX)

The telephone relay (TX) is energized by the application of a dc voltage to the relay. Because of its slow dropout characteristic a contact of the TX

relay is connected around the contact of the initiating relay to maintain voltage to the timing module of the relay if the contact of the initiating relay bounces. Refer to Fig. 5.

A resistor and diode are connected across the coil of the TX relay to protect the static components from the inductive voltage kicks associated with the telephone relay (TX) coil. A resistor is connected in series with the coil of the TX relay for use on 48/125 volts. This resistor is jumpered for 48 VDC operation. Operate time is 9ms - 48VDC, 6ms - 125VDC, Dropout time is 15ms.

### Indicating Contactor Switch (ICS)

The indicating contactor switch is a small dc operated clapper type device. A magnetic armature, to which leaf-spring mounted contacts are attached, is attracted to the magnetic core upon energization of the switch. When the switch closes, the moving contacts bridge two stationary contacts, completing the trip circuit. Also, during this operation two fingers on the armature deflect a spring located on the front of the switch, which allows the operation indicator target to drop. The target is reset from the outside of the case by a push rod located at the bottom of the cover.

The front spring, in addition to holding the target, provides restraint for the armature and thus controls the pickup value of the switch.

## OPERATION

Operation of the TD-5 relay occurs when a silicon controlled rectifier (SCR) switches from a non-conducting state to a conducting state. In the non-conducting state, the SCR acts as an opened switch to prevent energization of the telephone relay (TR), but in the conducting state acts as a closed switch to connect the telephone relay to the dc source. To switch the SCR from a non-conducting state to a conducting state requires that a maximum of 20 microamperes flow in the gate of the SCR. This current is produced by the difference in voltage across the capacitor (C) and the brush of the potentiometer (P).

When dc voltage is first applied to the relay,

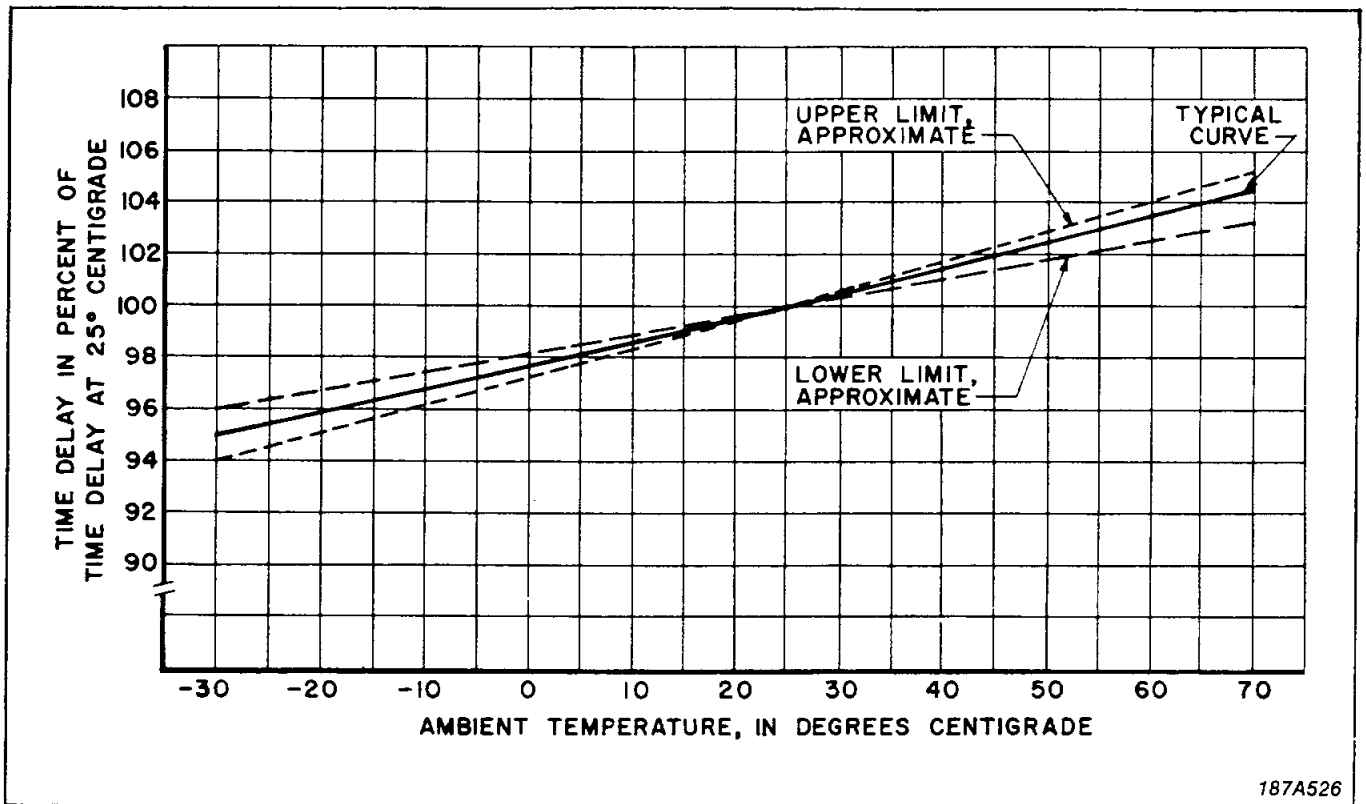

Fig. 3. Timing Variation with Temperature Changes.

voltage instantaneously appears across the potentiometer brush but is delayed in building up across the capacitor in accordance with the R-C time constant of the circuit. As long as the capacitor voltage is less than the potentiometer brush voltage, a reverse voltage appears across the diode  $D_2$ , and the SCR to keep the silicon controlled rectifier (SCR) biased off. When the capacitor voltage reaches the potentiometer brush voltage plus approximately one volt (forward voltage drop across SCR and  $D_2$ ), gate current will flow to the silicon controlled rectifier (SCR). This current switches the SCR to a conducting state to allow the telephone relay (TR) to pickup.

The SCR latches on when it switches and can be reset only by removing voltage from terminals 8 and 9. If a trip coil supervisory indicator lamp is used, when the timer is used with a fault detector to trip a breaker, a breaker "a" contact must be connected between terminal 8 of the relay and negative.

The rate at which the capacitor charges is determined by the rheostat setting. The charging

rate is not a linear function of rheostat setting, since  $R_p$  gives a parallel resistive path. This has the effect of expanding the scale for short times and thereby permitting more accurate settings.

## CHARACTERISTICS

### Time Delay Range and Voltage Rating

Time Delay Range (Seconds)	Voltage Rating (Volts dc)
.05-0.4	24/32
.05-0.4	48/125
.05-0.4	250
.05-1.0	24/32
.05-1.0	48/125
.05-1.0	250
0.2-4.0	24/32
0.2-4.0	48/125
0.2-4.0	250
1.5-30	24/32
1.5-30	48/125
1.5-30	250

## Battery Drain

	24 Volts dc	32 Volts dc	48 Volts dc	125 Volts dc	250 Volts dc
STAND-BY:	0	0	0	0	0
OPERATING:	500 MA	420 MA	270 MA	180 MA	80 MA

NOTE: TD-5 with TX Relay has an extra operating drain of 63 MA at 48 or 125 VDC.

## Voltage Rating Over The Temperature Range

The relay can stand 110% voltage continuously over a temperature range of  $-40^{\circ}\text{C}$ . to  $+70^{\circ}\text{C}$ .

## Reverse Polarity

Diode ( $D_1$ ) limits reverse voltage of the static components to less than one volt dc, so that no damage is done to the circuit by connecting the relay with reverse polarity. However, the relay will, of course, not operate under this condition, and series resistor ( $R_S$ ) may over-heat if reverse voltage is applied for approximately 15 minutes or more.

## Reset Time

TR drop-out time = 0.1 sec. or less. TR drop-out time of Relay with TX contact is an additional 15 msec.

Discharge of timing capacitor: the discharge of C is essentially instantaneous, the R-C time constant through P being less than 20 milliseconds, in most cases. However, the discharge path through P is limited by silicon voltage drops through SCR and  $D_2$ , totaling approximately one volt. Therefore, C discharges rapidly through P down to about one volt and then more slowly through  $R_P$  down to zero volts.

## Accuracy

The accuracy of the time delay depends upon the repetition rate of consecutive timings, the supply voltage, and the ambient temperature. Self-heating has a negligible effect on the time accuracy.

### (1) Nominal Setting

The first time delay, as measured with the test circuit shown in Figure 4, taken at  $25^{\circ}\text{C}$ . and rated voltage, will be within four milliseconds of its set-

ting for settings of 0.2 seconds or less. For settings above 0.2 seconds, this accuracy will be  $\pm 2\%$ .

### (2) Consecutive Timings

Incomplete capacitor discharge will cause changes in time delay. These changes are a function of discharge rate. Timing accuracy for slow repetitions will be per Table I.

**Table I**

Relay Rating	Delay Between Readings	Accuracy, as Percent of Setting
.05- 1.0 seconds	at least 3 seconds	$\pm 2\%$
0.2 - 4.0 seconds	at least 5 seconds	$\pm 2\%$
1.5 -30 seconds	at least 5 seconds	$\pm 2\%$

Timing accuracy for fast repetitions will be per Table II.

**Table II**

Relay Rating	Delay Between Readings	Accuracy, as Percent of Setting
.05- 1.0 seconds	instantaneous	$\pm 4\%$
0.2 - 4.0 seconds	instantaneous	$\pm 4\%$
1.5 -30 seconds	approx. $\frac{1}{2}$ sec.	$\pm 4\%$

### (3) Supply Voltage

Changes in supply voltage, between 80% and 110% of nominal, cause time delay variations of no more than  $\pm 3$  milliseconds for settings of 0.3 seconds or less, and no more than  $\pm 1\%$  for settings above 0.3 seconds.

### (4) Ambient Temperature

Changes in ambient temperature cause changes in time delay. This variation in time

delay is a direct function of capacitance change with temperature. Typical variation of time delay with temperature is shown in Figure 3.

## SETTINGS

Time delay is selected by adjusting rheostat, T.

- ⊕ For zone 2 distance applications, the timer setting should be sufficient to allow relays and breakers beyond the next bus to clear the fault. Also, it should be set to allow successful breaker-failure clearing without it operating. This usually requires a setting of approximately 0.25 seconds.
- ⊕ Zone 3 timing must coordinate with remote zone 2 timing. A typical setting is 0.5 seconds.
- ⊕ Breaker failure timing is set to assure normal fault clearing and fault detector reset plus 2 to 3 cycles margin. 0.1 to 0.2 second settings are typical.

The correct tap on series resistor,  $R_S$ , should be selected for the supply voltage being used.

### Indicating Contactor Switch (ICS)

No setting is required on the ICS unit except the selection of the 0.2 or 2.0 ampere tap setting. This selection is made by connecting the lead located in front of the tap block to the desired setting by means of the connecting screw.

## INSTALLATION

The relays should be mounted on switchboard panels or their equivalent in a location free from dirt, moisture, excessive vibration, and heat. Mount the relay vertically by means of the four mounting holes on the flange of semi-flush mounting or by means of the rear mounting stud or studs for projection mounting. Either a mounting stud or the mounting screws may be utilized for grounding the relay. The electrical connections may be made directly to the terminals by means of screws for steel panel mounting or to the terminal studs furnished with the relay for thick panel mounting. The terminal studs may be easily removed or inserted by locking two nuts on the stud and then turning the proper nuts with a wrench.

For detailed FT case information refer to I.L. 41-076.

## ADJUSTMENT AND MAINTENANCE

The proper adjustments to insure correct operation of this relay have been made at the factory and should not be disturbed after receipt by the customer. In particular, do not remove knob from rheostat shaft and do not loosen potentiometer lock nut.

### Acceptance Test

A timing check at minimum and maximum settings is recommended to insure that the relay is in proper working order. A recommended test circuit is shown in Figure 4. When testing the TD-5 with a TX telephone relay make the dotted connection as shown in Figure 4. The neon lamp will light if the TX relay is operating properly.

### Routine Maintenance

All contacts should be cleaned periodically. A contact burnisher S#182A836H01 is recommended for this purpose. The use of abrasive material for cleaning contacts is not recommended, because of the danger of embedding small particles in the face of the soft silver and thus impairing the contact.

### Trouble Shooting Procedure

Use the following procedure to locate the source of trouble if the TD-5 is not operating correctly.

1. Inspect all wires and connections, paying particular attention to telephone relay and printed circuit terminals.
2. Check the reference voltage circuit. This is done by measuring the dc voltage across the silicon power regulator, Z. Connect the dc voltmeter positive terminal to the rear terminal of  $R_S$  and the negative terminal to relay terminal 8. Apply rated voltage per the test circuit diagram, Figure 4. The Zener voltage should be between 11.0 and 14.0 volts for 24/32 volt relays, between 21.5 and 25.5 volts for 48/125 volt relays, and between 50 and 59 volts for 250 volt relays.

3. Check the timing capacitor voltage and the potentiometer brush voltage (between printed circuit terminal 3 and relay terminal 8) with a cathode ray oscilloscope or a high resistance dc voltmeter. It is necessary to scrape varnish from the capacitor positive terminal in order to make a connection at this point. The brush voltage, which is constant until the telephone relay trips, should be approximately one half the reference voltage. The capacitor should gradually change to the potentiometer brush voltage, plus approximately one volt for silicon junction forward voltage drops through SCR and D<sub>2</sub>.
4. If reference voltage, capacitor voltage, and potentiometer voltage all appear to behave correctly, the SCR may be the cause of trouble. The anode to cathode voltage, as measured between printed circuit terminals 4 and 3, should be approximately one-half the reference voltage until capacitor voltage reaches the brush voltage, at which time the anode to cathode voltage should drop to approximately one volt.

### Calibration

Use the following procedure for calibrating the relay if the relay adjustments have been disturbed. This procedure should not be used until it is apparent that the relay is not in proper working order. Before calibrating, follow the Trouble Shooting Procedure to locate the source of trouble.

#### 1. Telephone Type Relay Adjustment

Adjust the armature gap on the telephone type relay to be approximately .004 inch with the armature closed. This is done with the armature set-screw and lock-nut. Also, adjust contact leaf springs to obtain at least .015 inch gap on all contacts and at least .010 inch follow on all normally open contacts and at least .005 inch follow on all normally closed contacts.

#### 2. Rheostat Knob Adjustment, Same Scale Plate

If it is necessary to replace the rheostat (T) or the silicon power regulator (Z), the relay may be recalibrated with the same scale plate, in most cases. This is done by rotating the rheostat shaft, without knob, until a time delay equal to the

minimum scale marking is obtained. Then, align the knob for this delay and tighten the knob set-screw securely. Pause several seconds between readings for all delays above .05 seconds. See section under Accuracy for discussion of this.

#### 3. Scale Plate Calibration, New Scale Plate

If it is necessary to replace the potentiometer (P) or the printed circuit, the relay should be recalibrated with a new scale plate. Use the following procedure:

- (a). With the knob off the shaft, set the rheostat (T) at maximum.
- (b). Adjust P so that the times are 5% to 10% longer than the maximum scale marking.
- (c). Set the rheostat (T) at minimum and check that times are less than or equal to the minimum scale marking. If not, adjust P slightly to reduce times. Tighten lock nut on P.

- (d). Place the knob on the rheostat shaft in such a position that the times are symmetrical with respect to the scale plate marking. Tighten the knob set-screw and mark calibration lines on the scale plate. When striking calibration lines for delays above 0.5 seconds, pause at least 3 seconds between readings. See section under Accuracy for discussion of this.

#### 4. Indicating Contractor Switch (ICS)

Close the main relay contacts and pass sufficient dc current through the trip circuit to close the contacts of the ICS. This value of current should be not greater than the particular ICS tap setting being used. The operation indicator target should drop freely.

The contact wipe should be 1/64" to 3/64" between the bridging moving contact and the adjustable stationary contacts. The bridging moving contact should touch both stationary contacts simultaneously.

### RENEWAL PARTS

Repair work can be done most satisfactorily at the factory. However, interchangeable parts can be furnished to customers who are equipped for doing repair work. When ordering parts, always give the complete nameplate data.

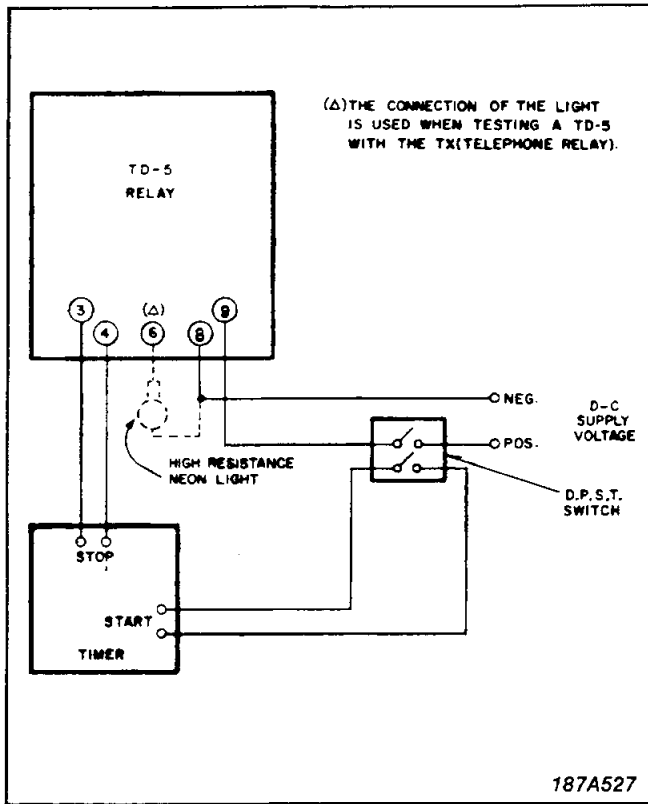

Fig. 4. Test Circuits for Type TD-5 Relay.

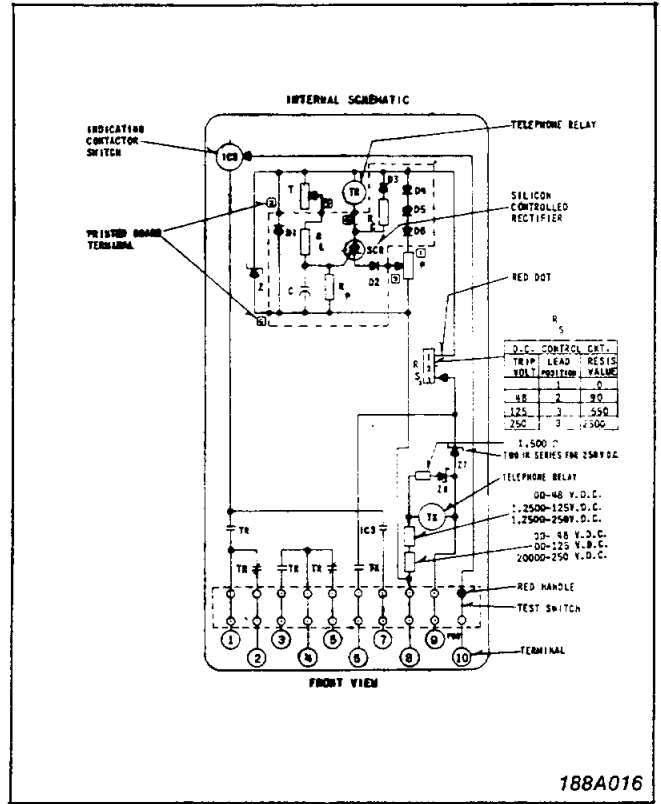
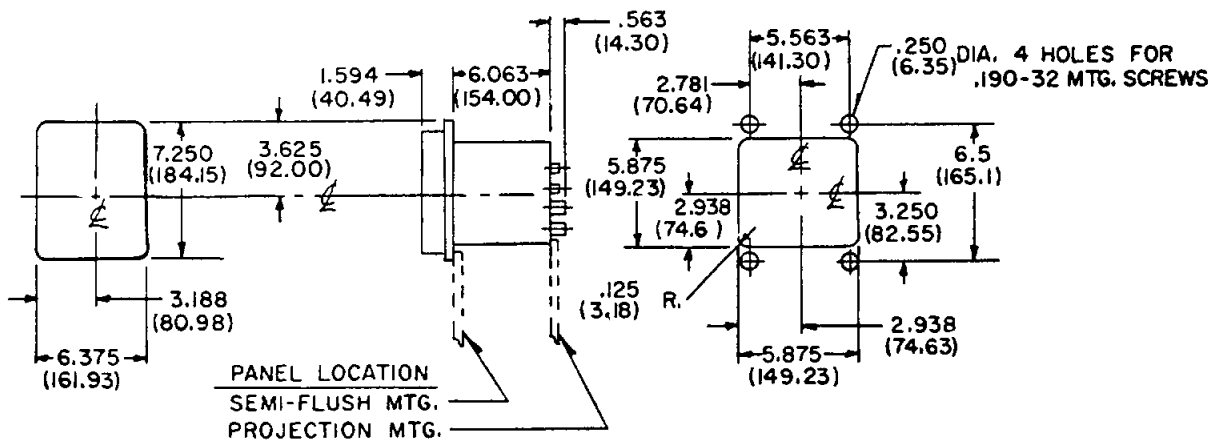

Fig. 5. Internal Schematic of TD-5 with Telephone Relay (TX).



TABLE OF REPLACEABLE PARTS

CIRCUIT SYMBOL	RELAY CHARACTERISTIC		DESCRIPTION	STYLE NUMBER
	DC VOL TS	TIME RANGES		
R <sub>S</sub>	24/32	All	Resistor, 40 Watts, 45 ± 5% ohms, center tap	184A064H03
	48/125	All	Resistor, 40 Watts, 550 ± 5% ohms, tap at 95 ohms	187A321H01
	250	All	Resistor, 40 Watts, 2500 ± 5% ohms	1995653
Z	24/32	All	Zener Diode, 1N2977B, 10 Watts, 13 Volts	629A798H02
	48/125	All	Zener Diode, 1N2986B, 10 Watts, 24 Volts	629A798H03
	250	All	Zener Diode, 1N2999B, 10 Watts, 56 Volts	629A798H04
D	All	All	Silicon Diode, 1N4818, 200 Volts, 0.75 Amp	188A342H06
Z7, Z8	All	All	Zener Diode 1N3051 (For TD-5 with T <sub>X</sub> only)	187A936H01
T	All	0.05-1	Rheostat, 3 Watt, 40K	184A756H01
	All	0.2 -4	Rheostat, 4 Watt, 100K	184A756H02
	All	1.5 -30	Rheostat, 4 Watt, 100K	184A756H02
	All	.05-.4	Rheostat, 4 Watt, 20K	184A756H04
R <sub>L</sub>	24/32	0.05-1 & .05-.4	Resistor, 1/2 Watt, 1K ± 1%	862A376H01
	48/125	0.05-1 & .05-.4	Resistor, 1/2 Watt, 1K ± 1%	862A376H01
	250	0.05-1 & .05-.4	Resistor, 3 Watts, 1K ± 5%	184A636H08
	All	0.2-4	Resistor, 1/2 Watt, 5.6K ± 1%	862A376H73
	All	1.5-30	Resistor, 1/2 Watt, 5.6K ± 1%	862A376H73
C	24/32	0.05-1 & .05-.4	Tantalum Capacitor, 22uf, 35 volts	184A661H16
	48/125	0.05-1 & .05-.4	Tantalum Capacitor, 22uf, 35 volts	184A661H16
	250	0.05-1 & .05-.4	Tantalum Capacitor, 22uf, 50 volts	184A661H17
	24/32	0.2-4	Tantalum Capacitor, 22uf, 35 volts	184A661H16
	48/125	0.2-4	Tantalum Capacitor, 22uf, 35 volts	184A661H16
	250	0.2-4	Tantalum Capacitor, 22uf, 50 volts	184A661H17
	24/32	1.5-30	Tantalum Capacitor, 22uf, (7 in parallel) 35 V	184A661H16
	48/125	1.5-30	Tantalum Capacitor, 22uf, (7 in parallel) 35 V	184A661H16
	250	1.5-30	Tantalum Capacitor, 22uf, (7 in parallel) 50 V	184A661H17
	R <sub>P</sub>	All	0.05-1 & .05-.4	Resistor, 1/2 W, 62K ± 1%
All		0.2-4	Resistor, 1/2 Watt, 267K ± 1%	184A764H85
All		1.5-30	Resistor, 1/2 Watt, 267K ± 1%	184A764H85
T <sub>R</sub>	24/32	All	Telephone Relay, 30 ohm coil	407C614H05
	48/125	All	Telephone Relay, 125 ohms coil	407C614H06
	250	0.05-1 & .05-.4	Telephone Relay, 125 ohm coil	407C614H06
	250	0.2-4	Telephone Relay, 650 ohm coil	407C614H07
	250	1.5-30	Telephone Relay, 650 ohm coil	407C614H07
T <sub>X</sub>	48/125	All	Telephone Relay 750 ohm coil	19B1312H09
R <sub>C</sub>	24/32	All	Resistor, 1/2 Watt, 56 ± 5% ohms	187A290H19
	48/125	All	Resistor, 1/2 Watt, 270 ± 5% ohms	184A763H13
	250	All	Resistor, 1/2 Watt, 1200 ± 5% ohms	184A763H29
SCR	24/32	All	Silicon Controlled Rectifier, 2N885	185A517H02
	48/125	All	Silicon Controlled Rectifier, 2N885	185A517H02
	250	All	Silicon Controlled Rectifier, 2N886	185A517H03
P	24/32	All	Potentiometer, 4 Watts, 60 ± 10% ohms	185A067H04
	48/125	All	Potentiometer, 4 Watts, 250 ± 10% ohms	185A067H05
	250	All	Potentiometer, 4 Watts, 1300 ± 10% ohms	185A067H06



PANEL CUTOUT & DRILLING FOR SEMI-FLUSH MTG.

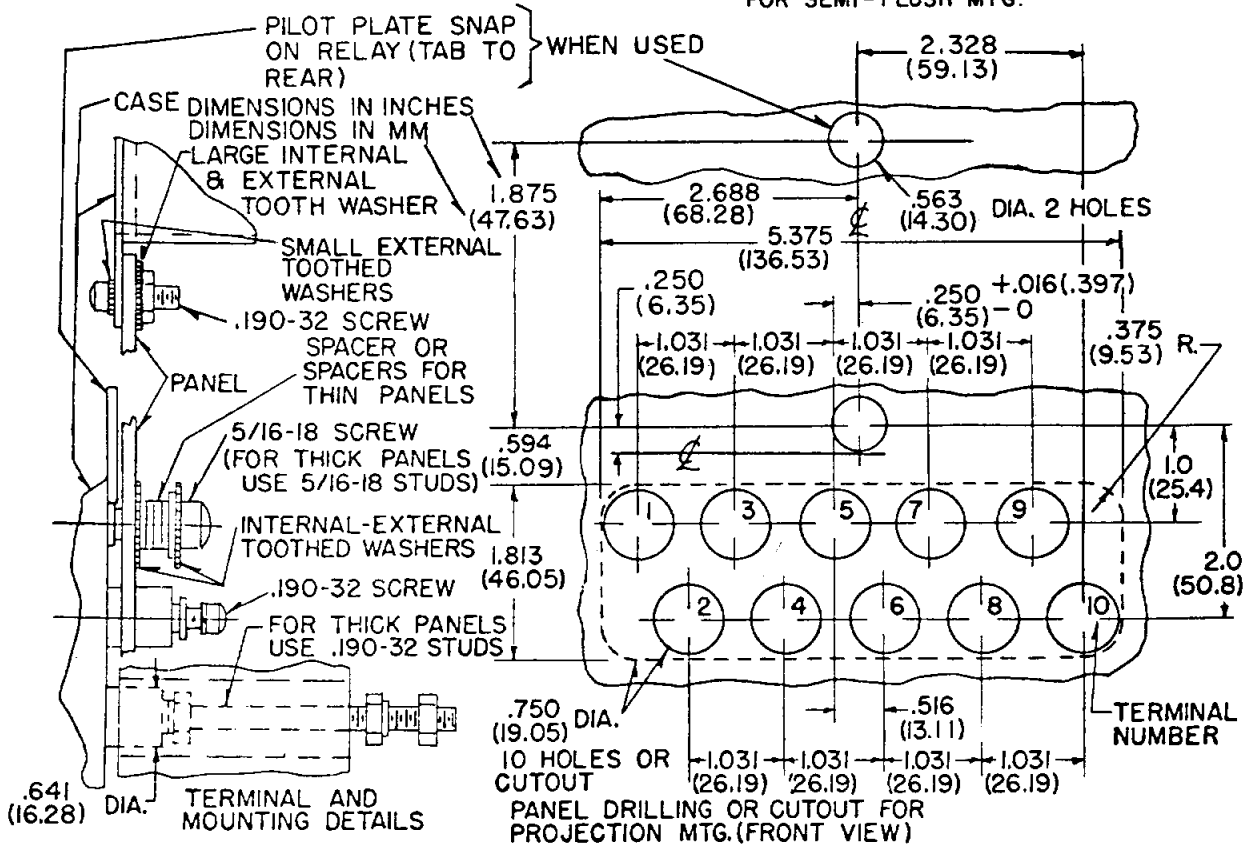

Fig. 6. Outline and Drilling Plan for Type TD-5 Relay in Type FT11 Case.