



Effective: November 1980  
Supersedes I.L.41-222.4B, Dated May 1977

⊕ Denotes Changed Since Previous Issue

## Type KP

# Three Phase Voltage And Phase Sequence

**CAUTION:** Before putting relays into service, remove all blocking which may have been inserted for the purpose of securing the parts during shipment, make sure that all moving parts operate freely, inspect the contacts to see that they are clean and close properly, and operate the relay to check the settings and electrical connections.

### APPLICATION

The type KP relay is a three phase high speed voltage and phase sequence relay.

This relay can be used as either an undervoltage or overvoltage fault detector. In addition, it can also be used to check phase sequence of a three phase voltage.

### CONSTRUCTION AND OPERATION

The type KP relay consists of a high speed cylinder unit with an adjustable spring and an indicating contactor switch when required.

#### Voltage Unit

The voltage unit is a product induction cylinder type unit.

Mechanically, the overcurrent unit is composed of three basic components: a die-cast aluminum frame and electromagnet, a moving element assembly, and a molded bridge.

The frame serves as the mounting structure for the magnetic core. The magnetic core which houses the lower pin bearing is secured to the frame by a spring and snap ring. The bearing can be replaced, if necessary, without having to remove the magnetic core from the frame.

The electromagnet has two pairs of coils. The coils of each pair are mounted diametrically opposite one another. In addition, there are two locating pins. The locating pins are used to accurately position the lower pin bearing, which is mounted on the frame, with respect to the upper pin bearing, which is

threaded into the bridge. The electromagnet is permanently secured to the frame and cannot be separated from the frame.

The moving element assembly consists of a spiral spring, contact carrying member, and an aluminum cylinder assembled to a molded hub which holds the shaft. The shaft has removable top and bottom jewel bearings. The shaft rides between the bottom pin bearing and the upper pin bearing with the cylinder rotating in an air gap formed by the electromagnet and the magnetic core.

The bridge is secured to the electromagnet and frame by two mounting screws. In addition to holding the upper pin bearing, the bridge is used for mounting the adjustable stationary contact housing. The stationary contact housing is held in position by a spring type clamp. The spring adjuster is located on the underside of the bridge and is attached to the moving contact arm by a spiral spring. The spring adjuster is also held in place by a spring type clamp.

With the contacts closed, the electrical connection is made through the stationary contact housing clamp, to the moving contact, through the spiral spring out to the spring adjuster clamp.

The voltage at which the contacts either pickup or dropout can be varied by means of moving the spring adjuster.

#### Indicating Contactor Switch Unit (ICS)

The indicating contactor switch is a small d-c operated clapper type device. A magnetic armature, to which leaf-spring mounted contacts are attached, is attracted to the magnetic core upon energization of the switch. When the switch closes, the moving

*All possible contingencies which may arise during installation, operation or maintenance, and all details and variations of this equipment do not purport to be covered by these instructions. If further information is desired by purchaser regarding this particular installation, operation or maintenance of this equipment, the local ABB Power T&D Company Inc. representative should be contacted.*

# TYPE KP THREE PHASE VOLTAGE AND PHASE SEQUENCE RELAY

contacts bridge two stationary contacts, completing the trip circuit. Also during this operation two fingers on the armature deflect a spring located on the front of the switch, which allows the operation indicator target to drop. The target is reset from the outside of the case by a push rod located at the bottom of the cover.

The front spring, in addition to holding the target, provides restraint for the armature and thus controls the pickup value of the switch.

## Contacts

The moving contact assembly in the KP voltage unit has been factory adjusted for low contact bounce performance and should not be disturbed.

The set screw in each stationary contact has been shop adjusted for optimum follow and this adjustment should not be disturbed.

## CHARACTERISTICS

The type KP relay can be adjusted by means of the spring adjuster on the cylinder unit for a range of pickup or dropout of 30 to 120 volts three phase. Factory calibration is 70 volts.

The KP Voltage Relay will also respond to phase to phase voltage conditions as well as three phase voltage. A conversion curve between both is shown in Fig. 4.

The relay has inverse timing; that is, the greater the decrease, or the greater the increase, in voltage, the faster the relay contacts will close. Typical time curves are shown in Figures 5 and 6.

## Trip Circuit

The main contacts will safely close 30 amperes at 250 volts d-c and the seal in contacts of the indicating contactor switch (when supplied) will safely carry this current long enough to trip a circuit breaker. The indicating contactor switch (when supplied) has a pickup of approximately 1 ampere. Its d-c resistance is 0.1 ohms.

## Energy Requirements

### Burden at rated 120 Volts ac

Phase A to B;

watts — 1.44

vars. — 2.40

Volt-amperes — 2.80

power factor angle — 59° Lag.

Phase C to B

watts — 1.45

vars. — 2.33

volt-amperes — 2.75

power factor angle — 58° Lag.

Continuous rating of the KP relay is 132 volts ac.

## SETTINGS

The KP Voltage Relay is factory calibrated and set for a dropout of 70 volts. However, if another voltage setting is required, then the following procedure should be used to recalibrate the relay:

If the relay is to be used as an undervoltage relay, apply the required three phase dropout voltage and make the following adjustment. Move the spring adjuster mounted just under the bridge of the cylinder unit until the mounting contact just touches the right hand stationary contact. For an overvoltage setting, use the same procedure except that the moving contact must just touch the left hand stationary contact.

The maximum range of adjustment is 30 to 120 volts, three phase. Looking at the front view and from the top of the KP relay, the 30 volt adjustment of the spring will be towards the full clockwise position of adjustment. The 120 volt calibration point will be towards the full counter-clockwise position of the spring adjuster.

Note: In order to adjust the spring, place a screwdriver or similar tool into one of the notches located on the periphery of the spring adjuster and rotate it.

## INSTALLATION

The relays should be mounted on switchboard panels or their equivalent in a location free from dirt, moisture, excessive vibration and heat. Mount the relay vertically by means of the rear mounting stud or studs for the type FT projection case or by means of the four mounting holes on the flange for the semi-flush type FT case. Either the stud or the mounting screws may be utilized for grounding the relay. External toothed washers are provided for use in the locations shown on the outline and drilling plan to facilitate making a good electrical connection between the relay case, its mounting screws or studs, and the relay panel. Ground wires are affixed to the mounting to the mounting screws or studs as required for poorly grounded or insulating panels. Other electrical connections may be made directly to the terminals by means of screws for steel panel mounting or to the terminal stud furnished with the relay for thick panel mounting. The terminal stud may be easily removed or inserted by locking two nuts on the stud and then turning the proper nut with a wrench.

For detail information on the FT case refer to I.L. 41-076.

## ADJUSTMENTS AND MAINTENANCE

The proper adjustments to insure correct operation of this relay have been made at the factory. Upon receipt of the relay, no customer adjustments, other than those covered under "Settings," should be required.

### Acceptance Check

The following check is recommended to insure that the KP Relay is in proper working order:

#### A. Voltage Unit

1. contact gap – the contact gap should be approximately 0.020”:
2. voltage setting – a voltage setting of 70 volts was made at the factory. This can be checked by applying 70 volts three phase to the relay and the moving contact should be just floating or touching the right-hand stationary contact within  $\pm 3\%$  of this value. Greater accuracy can be obtained by pre-heating the relay at normal line voltage for approximately one hour.

#### B. Indicating Contactor Switch (ICS)

Close the main relay contacts and pass sufficient d-c current through the trip circuit to close the contacts of the ICS. This value of current should be between 1 and 1.2 amperes. The indicator target should drop freely.

The contact gap should be approximately 5/64” between the bridging moving contact and the adjustable stationary contacts. The bridging moving contacts should touch both stationary contacts simultaneously.

### Routine Maintenance

All relays should be inspected periodically and the operation should be checked at least once every year or at such other time intervals as may be dictated by experience to be suitable to the particular application.

All contacts should be periodically cleaned. A contact burnisher S#182A836H01 is recommended for this purpose. The use of abrasive material for cleaning contacts is not recommended because of the danger of embedding small particles in the face of the soft silver and thus impairing the contact.

### Calibration

Use the following procedure for calibrating the relay if the relay has been taken apart for repairs or the adjustments have been disturbed. This procedure should not be used unless it is apparent that the relay is not in proper working order. (See "Acceptance Check").

#### A. Voltage Unit

1. The upper pin bearing should be screwed down until there is approximately .025 clearance between it and the top of the shaft bearing. The upper pin bearing should then be securely locked in position with the lock nut. The lower bearing position is fixed and cannot be adjusted.
2. The contact gap adjustment for the under-voltage unit is made with the moving contact in the reset position, i.e., against the right side of the molded bridge. Advance the right hand stationary contact until it just touches the moving contact. Then advance the stationary contact  $\frac{1}{4}$  turn. Now screw in the left hand stationary contact until it just touches the moving contact. Then back off the left hand stationary contact one turn for a gap of approximately 1.020”. The clamp holding the stationary contact housing need not be loosened for the adjustment since the clamp utilizes a spring-type action in holding the stationary contact in position.
3. For greater accuracy pre-heat the relay by applying rated voltage for approximately one hour prior to setting the sensitivity.

The sensitivity adjustment is made by varying the tension of the spiral spring attached to the moving element assembly. The spring is adjusted by placing a screwdriver or similar tool into one of the notches located on the the periphery of the spring adjuster and rotating it. The spring adjuster is located on the underside of the bridge and is held in place by a spring type clamp that does not have to be loosened prior to making the necessary adjustments.

Apply the desired dropout voltage to the relay and adjust the spiral spring as noted above until the moving contact just floats or makes with the right hand stationary contact.

## TYPE KP THREE PHASE VOLTAGE AND PHASE SEQUENCE RELAY

### B. Indicating Contactor Switch (ICS)

Adjust the contact gap for approximately  $5/64''$   
( $-1/64''$ ,  $+0$ ).

Close the main relay contacts and check to see  
that the relay picks up and the target drops between  
1 and 1.2 amperes dc.

To increase the pickup current remove the molded  
cover and bend the springs out or away from the

cover. To decrease the pickup current bend the  
springs in toward the cover.

### RENEWAL PARTS

Repair work can be done most satisfactorily  
at the factory. However, interchangeable parts can  
be furnished to the customers who are equipped for  
doing repair work. When ordering parts, always give  
the complete nameplate data.

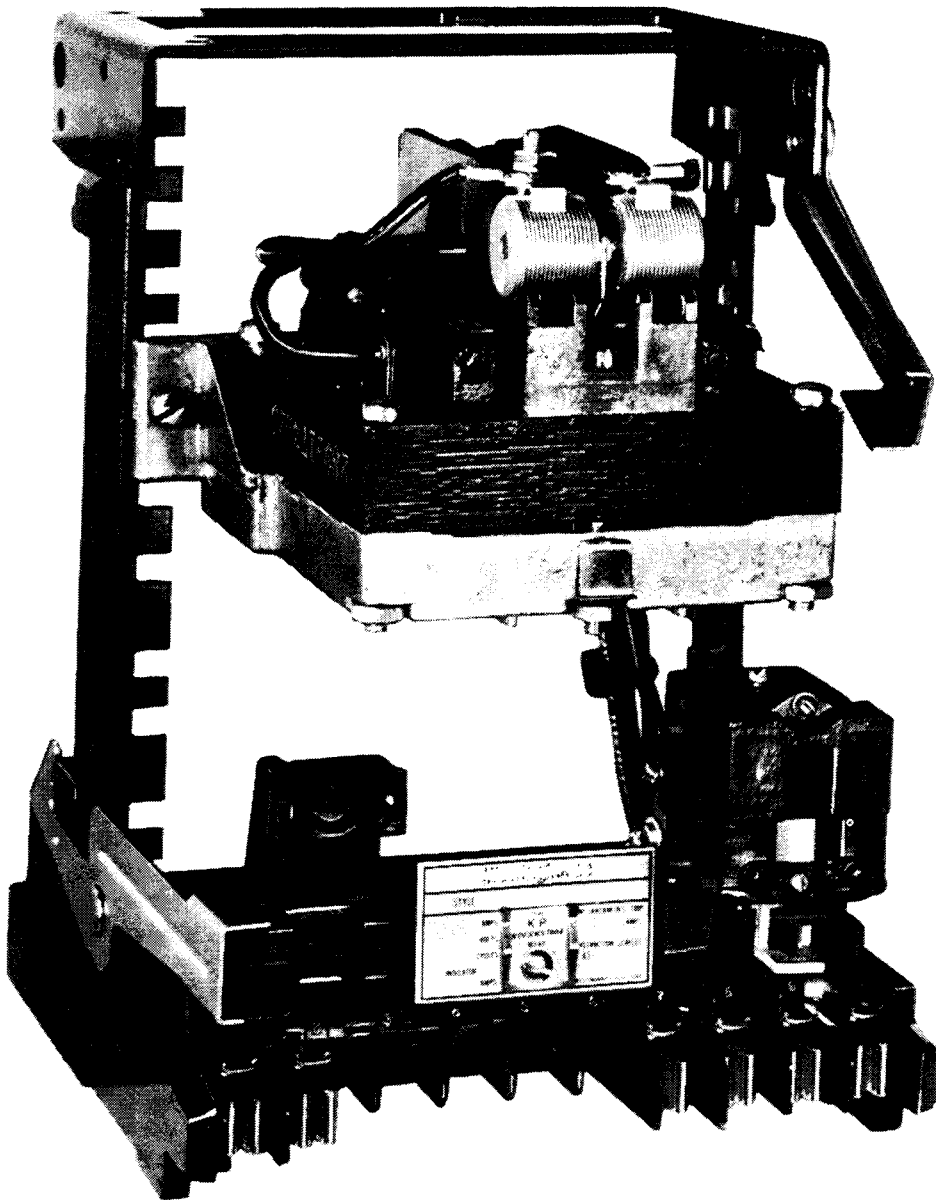

Fig. 1. Photograph - Type KP Relay without case.

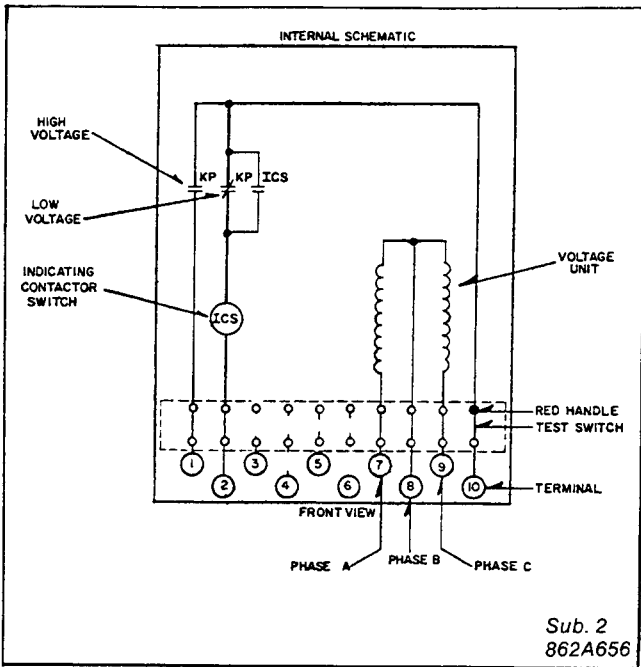

Fig. 2. Internal Schematic – Type KP Voltage Relay with an ICS in the Low Voltage circuit in the type FT21 case.

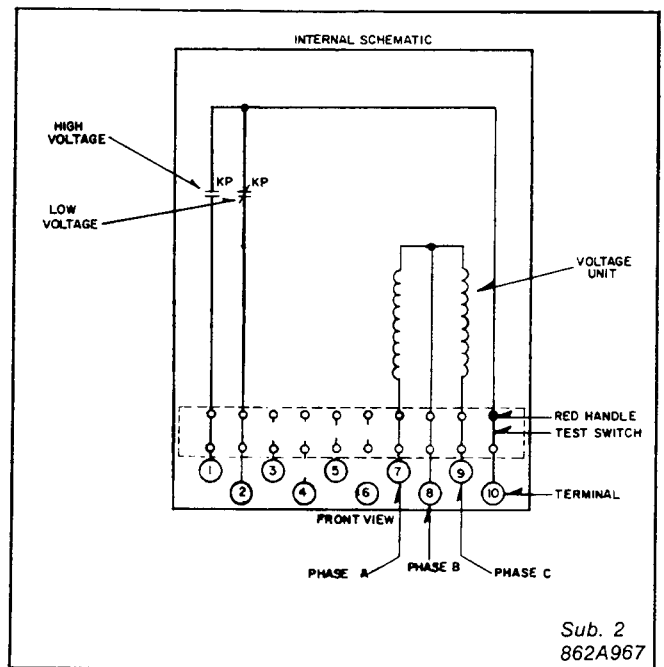

Fig. 3. Internal Schematic – Type KP Voltage Relay in the type FT21 case.

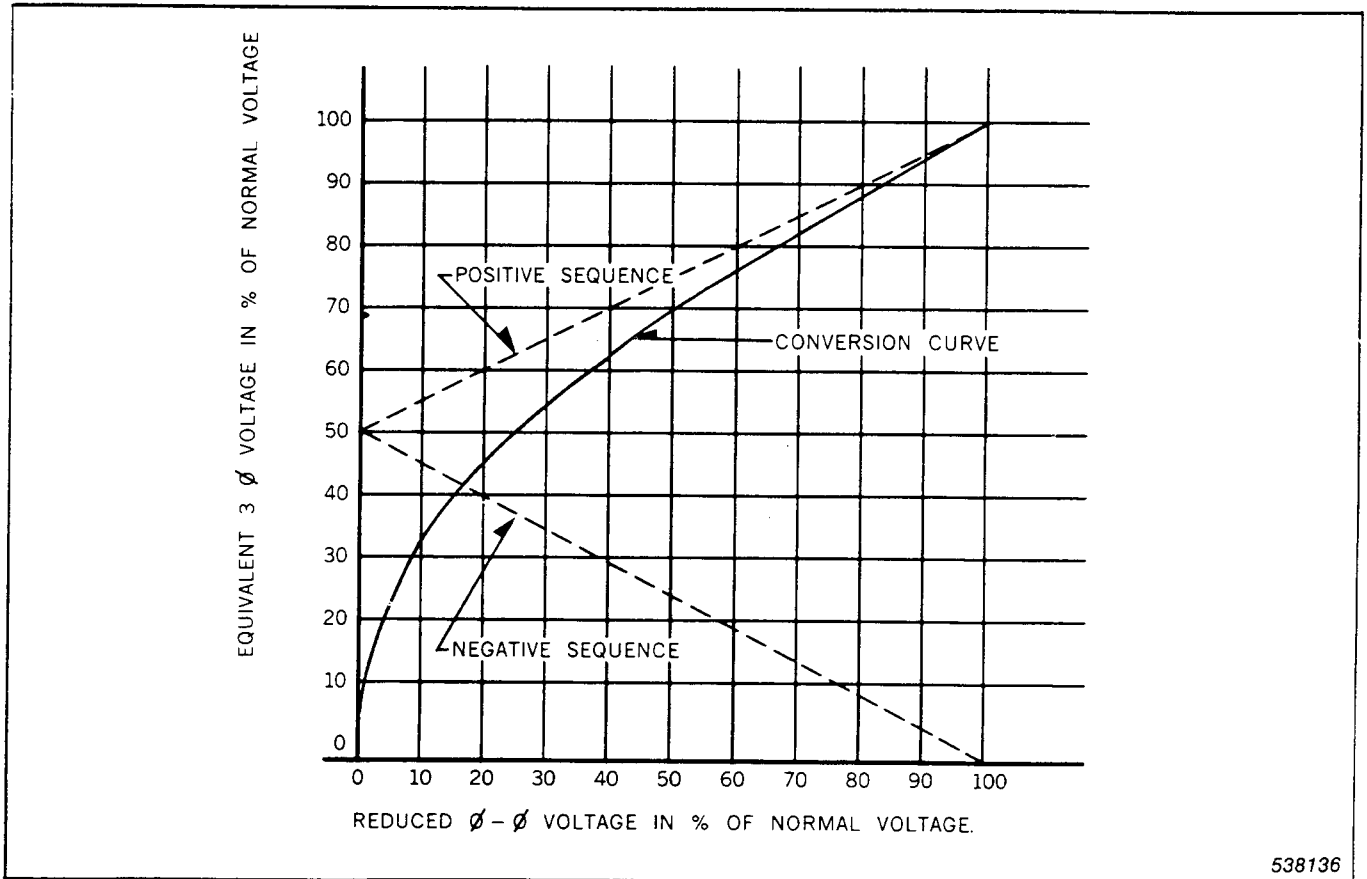

Fig. 4. Conversion curve for three phase vs. phase to phase voltages for the type KP Voltage Relay.

**TYPE KP THREE PHASE VOLTAGE  
AND PHASE SEQUENCE RELAY**

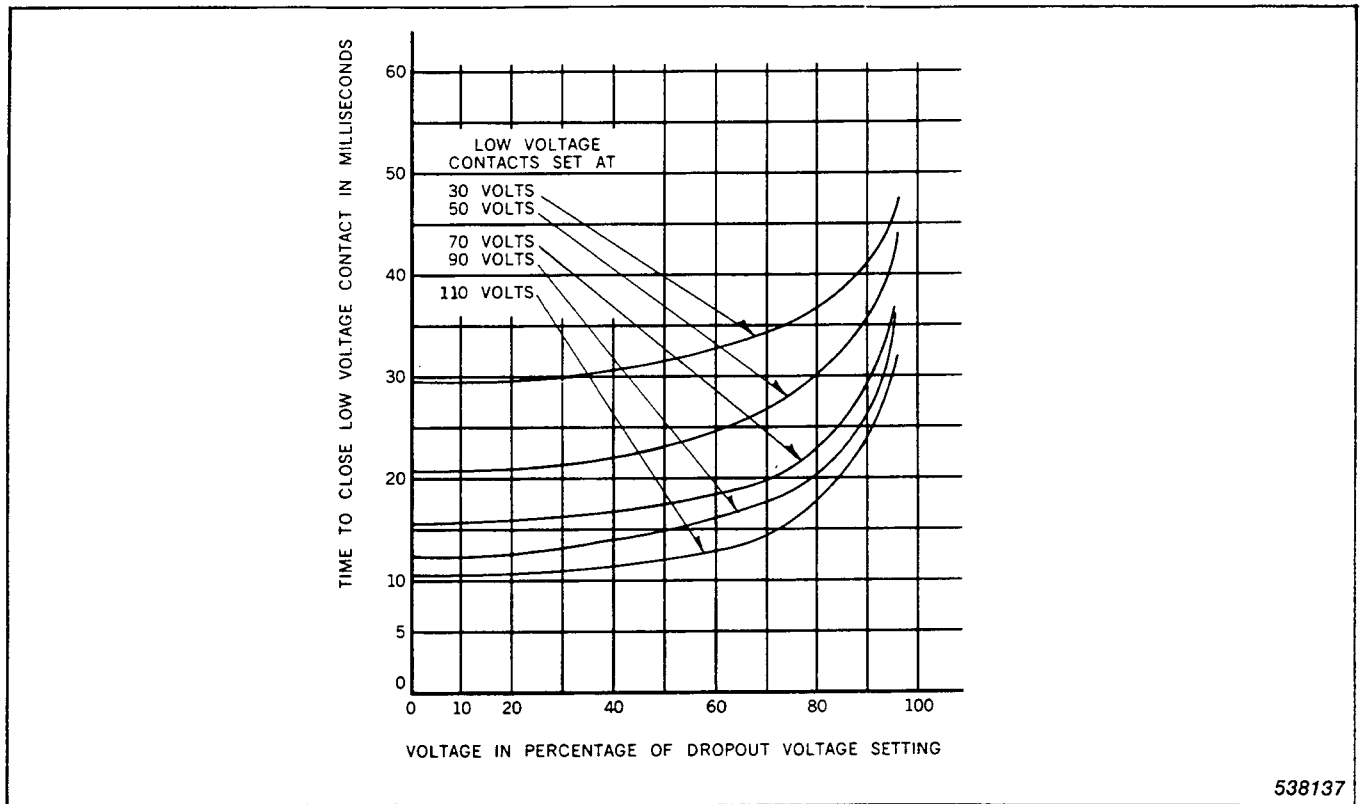

Fig. 5. Typical undervoltage time curves for the type KP Voltage Relay.

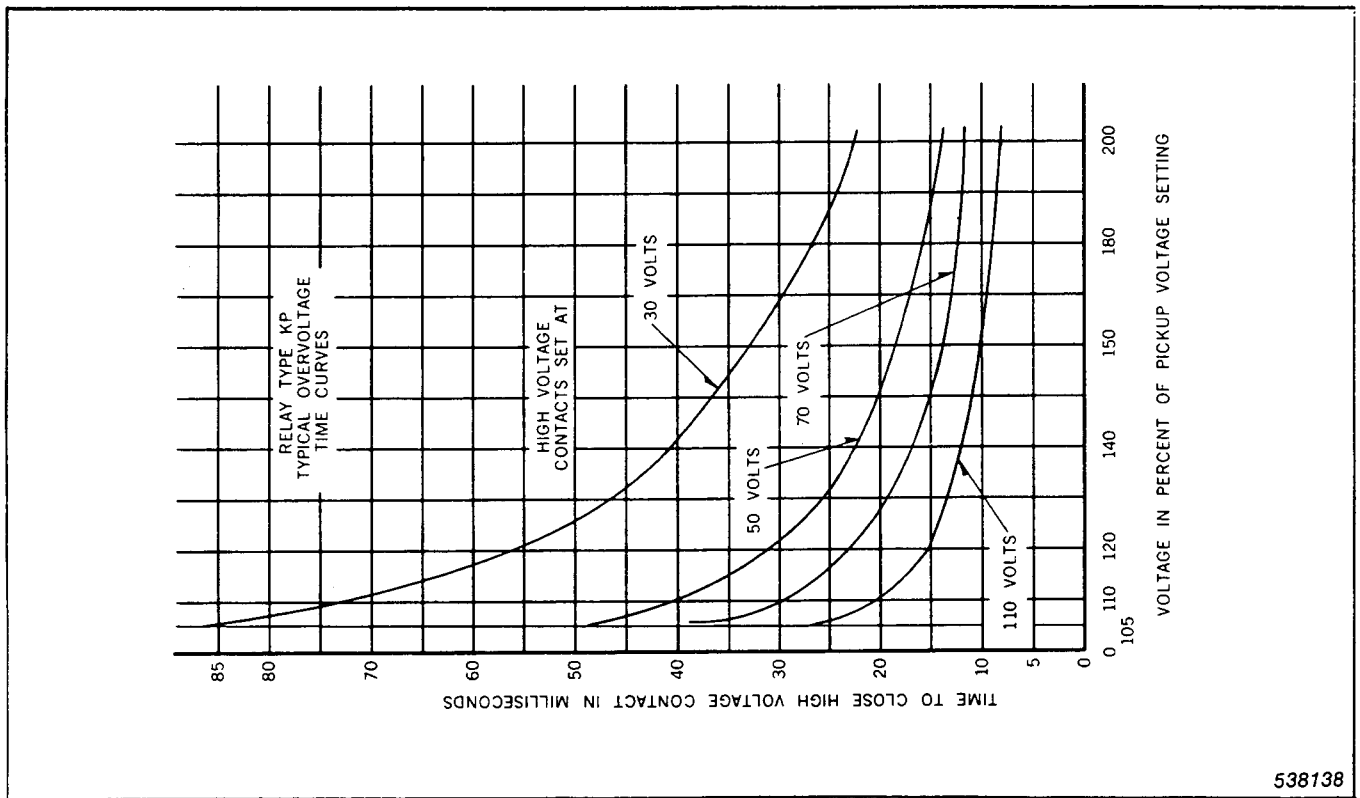
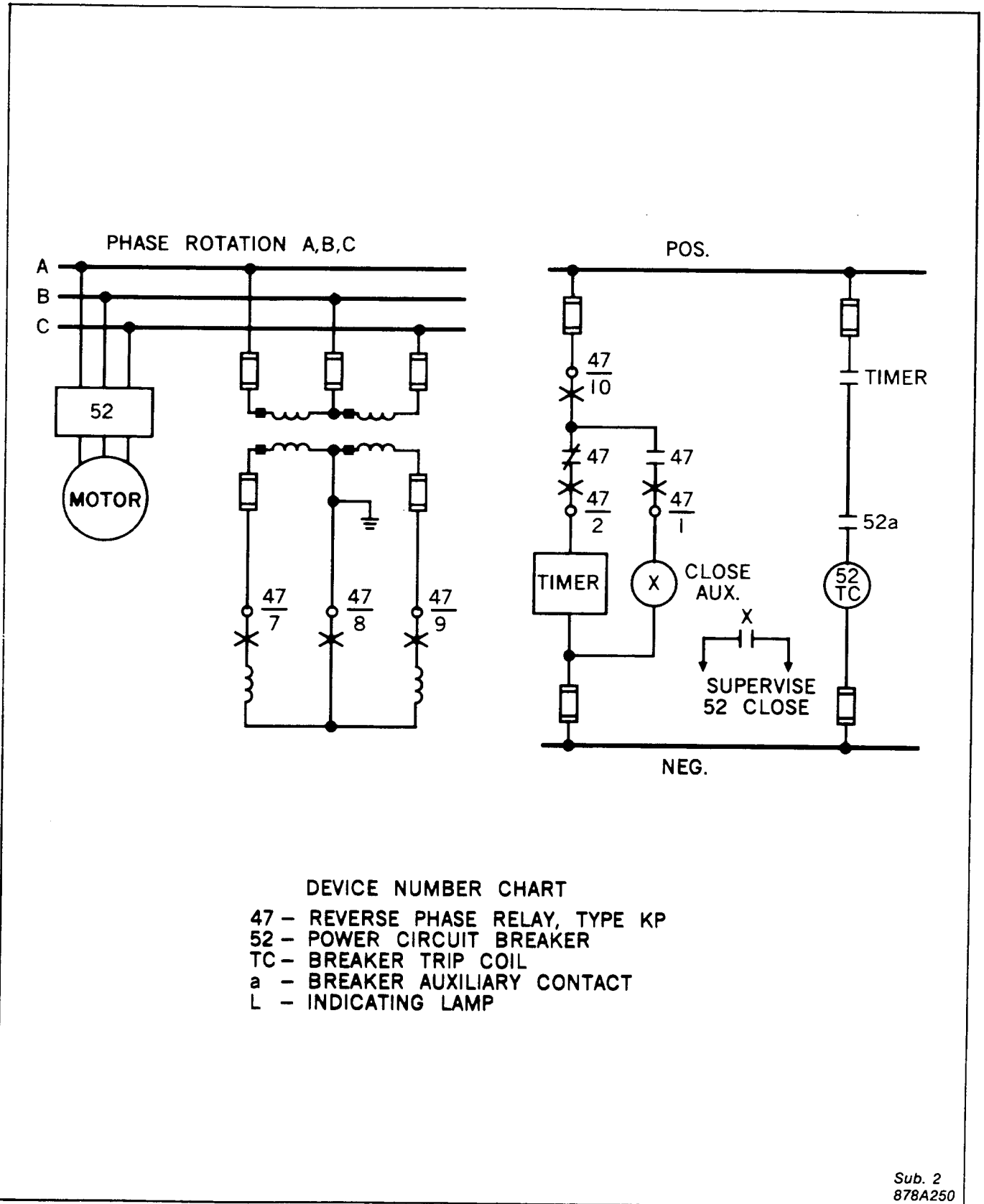

Fig. 6. Typical overvoltage time curves for the type KP Voltage Relay.



★ Fig. 7. External schematic diagram for the type KP Voltage Relay in the type FT21 case.

**TYPE KP THREE PHASE VOLTAGE  
AND PHASE SEQUENCE RELAY**

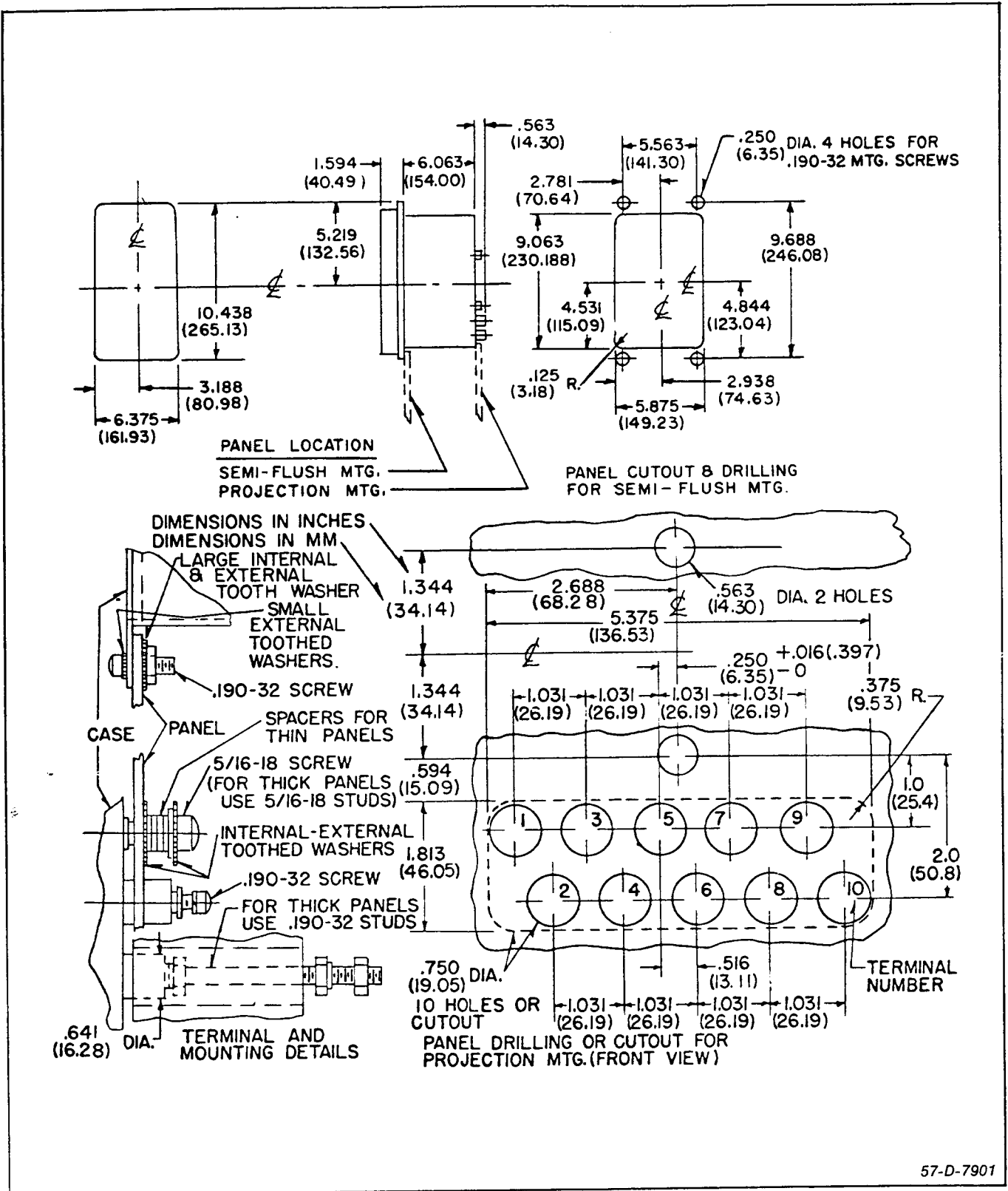

Fig. 8. Outline and drilling plan for the Type KP Voltage Relay in the type FT21 case.

**ABB Network Partner**

ABB Power T&D Company Inc.  
4300 Coral Ridge Drive  
Coral Springs Florida 33065  
(954) 752-6700  
FAX: (954) 345-5329



Printed in U.S.A.