



Type D-3 Direct Current Relay

Effective January 1976
Supersedes I.L. 41-151.1G dated April 1975

* Denotes change since previous issue

CAUTION

Before putting relays into service, remove all blocking which may have been inserted for the purpose of securing the parts during shipment, make sure that all moving parts operate freely, inspect the contacts to see that they are clean and close properly, and operate the relay to check the settings and electrical connections.

APPLICATION

The type D-3 relay is suitable for applications where overload, underload, or reverse-current protection is required on direct current circuits. One particular application is in the protection of rotary converters which require sensitive reverse-current relays to prevent running inverted.

In the usual application of the D-3 relay the moving coil is connected to a shunt in the circuit being protected. By suitable selection of relay calibration and of shunt rating, the relay can be made to respond to particular magnitudes or directions of current flow through the shunt as required.

In applications where the D-3 relay is used for the purpose of regulating a load, closing of the overload contacts will initiate action to reduce the amount of the load. Since the relay is very sensitive, a slight reduction in load will cause the overload contacts to open. If the reduction of load is interrupted, the relay will close contacts again on a small load increase. Thus small load fluctuations might cause excessive operation of the relay and the device controlled by it. The connections of Fig. 5 show the use of an external auxiliary relay (type SG) to keep the controlled device energized until the load has dropped by an amount determined by the setting of the left-hand contact of the D-3 relay. Fig. 6 shows how this feature has been added to some styles.

CONSTRUCTION

The type D-3 relay is a d'Arsonvol type d.c. contact making voltmeter consisting of a moving coil, permanent magnet, and contacts. The magnetic circuit is shown schematically in Fig. 1.

Permanent Magnet

The permanent magnet is a cylindrical core, consisting of an Alnico permanent magnet, two iron pole pieces and two brass spacer blocks. This magnet is mounted concentrically in the bore of a malleable iron frame.

A magnetic field is produced by the permanent magnet in the air gap between the magnet and the iron frame. The path of magnetic flux is from the Alnico magnet through the iron pole piece across the air gap to the iron frame. The return path of the flux is through the frame across the second air gap to the second pole piece. The pole pieces and the bore of the frame are shaped such that a uniform flux distribution is obtained in the air gaps.

Moving Coil

The moving coil rotates in the air gap between the core and the iron frame. Electrical connections are made to the coil through two springs located at the top of the element. One end of each spring is connected through a lever arm to a head of the coil. The other end of each spring is fastened to posts mounted in a circular insulation plate. This plate can be rotated to permit adjustment of the zero position of the moving element.

A third spiral spring located at the bottom of the element provides a current path to the moving contact.

Auxiliary Switch (CS-1) (When Used)

The auxiliary switch is a small solenoid type switch. A cylindrical plunger with a silver disc

All possible contingencies which may arise during installation, operation or maintenance, and all details and variations of this equipment do not purport to be covered by these instructions. If further information is desired by purchaser regarding this particular installation, operation or maintenance of this equipment, the local ABB Power T&D Company Inc. representative should be contacted.

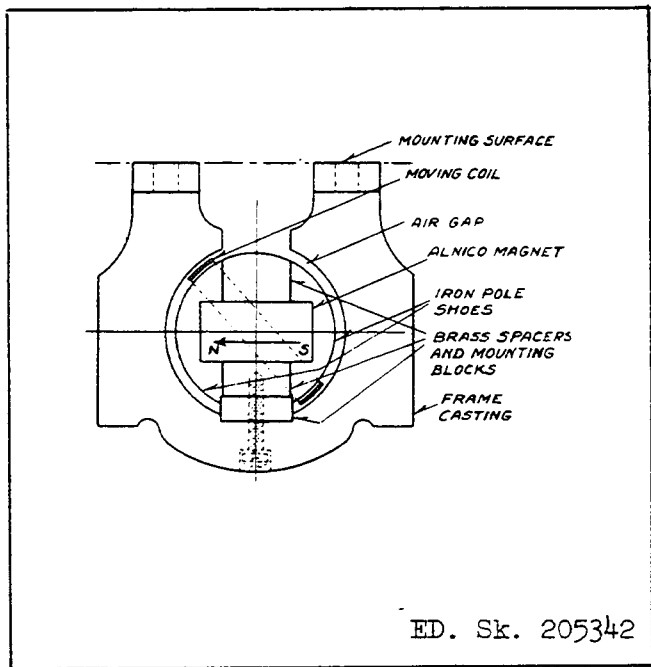
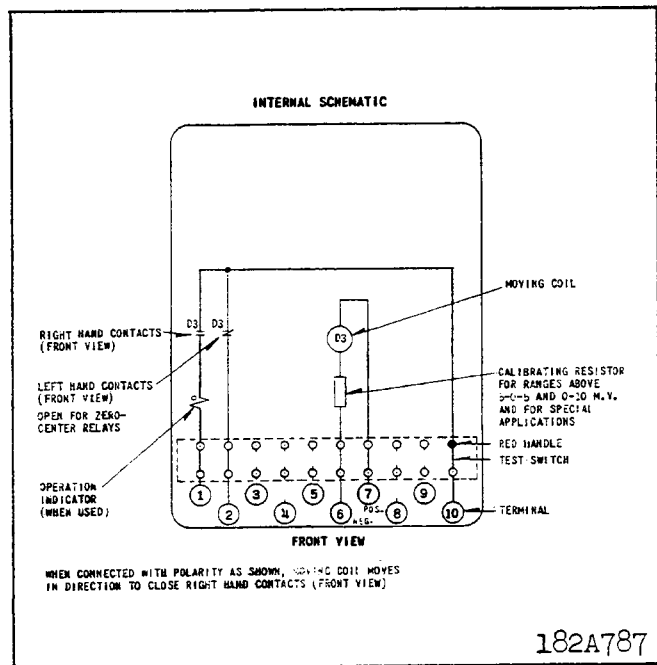

Fig. 1. Schematic Drawing of Magnetic Circuit of Type D-3 Relay (Top View). Moving Coil Bearing Supports, Springs and Contacts Omitted.



* Fig. 2. Internal Schematic of the Type D-3 Relay in the Type FT21 Case.

mounted on its lower end moves in the core of the solenoid. As the plunger travels upward, the disc bridges three silver stationary contacts.

* Operation Indicator (When Used)

The operation indicator consists of a small solenoid coil mounted in a steel frame, a spring restrained armature and a white flag. The indicator is reset by a push rod in the cover.

OPERATION

The D-3 relay operates on the principle of a current carrying conductor (moving coil) located in a magnetic field (permanent magnet). When a current is applied to the coil of the relay, a torque is produced that rotates the moving coil until the electrical torque is equal to the torque of the restraining spring. The moving contact will assume a position in its travel that is proportional to the current applied to the moving coil.

The direction of movement of the moving coil is determined by the polarity of the current applied to the coil. In the "left zero" and "suppressed zero" D-3 relays, the contacts will move to the right when a current of the proper magnitude and polarity is applied to the relay. On the other hand, the contact of the "center zero" relay will move either left or right depending on the polarity and magnitude of the applied current.

CHARACTERISTICS

The type D-3 relay is supplied in the standard ranges listed in the table below. The numbers on the scale indicate in millivolts the potential required at the relay base terminals to operate the moving element to the indicated scale position.

MOVING COIL CIRCUIT

Ranges in Millivolts, d-c	Average Resistance in Ohms at 25°C
0-10	0.3
5-0-5	0.3
40-80	1.2
100-0-100	6.0
0-200	6.0

* Other ranges can also be supplied.

As shown in the above Table, the D-3 relay is available with a "left zero," "suppressed zero" and "center zero" scale. In the "left zero" and the "suppressed zero" relays the moving contact is located in the extreme left hand position of the scale when the relays are deenergized. The "suppressed zero" relay is held in this position with considerable more force than the "left zero" relay. When the relays are energized with voltages of the proper magnitude and polarity, the moving contact moves to the right.

In the "center zero" relay, the moving contact is located in the center of the scale when the relay is

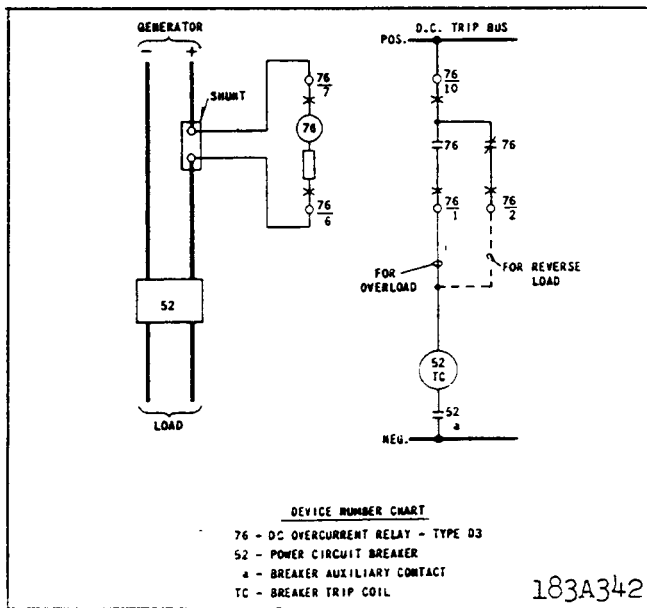

Fig. 3. External Schematic Diagram for Overload or Reverse Current Protection, using the Type D-3 Relay.

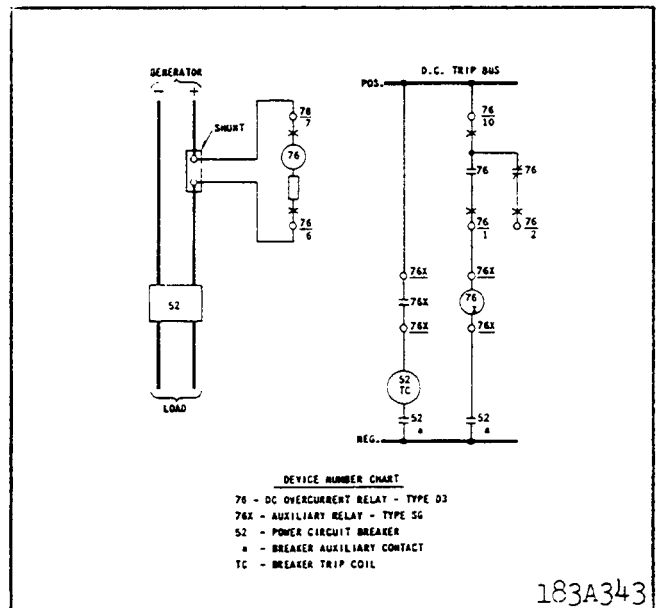

Fig. 4. External Schematic Diagram for Overload Protection where Trip Currents in Excess of One Ampere Rating Require Use of an Auxiliary Relay.

deenergized. When the relay is energized, the contact will move either to the right or left depending upon the polarity of the applied voltage.

A modification of the D-3 relay, in which a rectifier is mounted internally, makes it suitable for a.c. operation. Full scale deflection can be obtained with 6 milliamperes a.c. Relays modified for AC volts can also be supplied.

The relay has a slight time-delay, with inverse characteristics. In the usual application the moving coil terminals are connected across a shunt, and this results in longer delay for both operating and reset times. When a shunt is used the operating time for full scale travel at 125% of the full scale operating current is about 4 seconds, while at 1000% it is about .25 second. In applications where no shunt is used, the operating times for the same conditions are about 1.25 and .15 second respectively. When the relay is de-energized, the time required for it to reset from the full scale position to the 10% position is approximately 5 seconds when a shunt is used, and 2 seconds when there is no shunt.

Continuous maximum overload is approximately 1500% of full scale.

The minimum setting which D-3 Relay can accommodate is 5% of the full scale.

SETTINGS

For reverse-current protection a sensitivity of 2 per cent is obtained when using a standard 50 milli-

volt shunt and setting the relay at 1 millivolt. A 10 per cent sensitivity is obtained by setting the relay at 5 millivolts. These values of sensitivity can be doubled by using a 100 millivolt shunt.

For overload protection the relay is set at the index setting which, with respect to the millivolt drop of the shunt, will operate at desired per cent of overload.

TRIP CIRCUIT

contacts	d-c control voltage	amperes contacts will: (non-inductive load)		
		open	close	carry continuously
D-3 relay	125 v	0.04♦	1.0	...
	250 v	0.02♦	1.0	...
contactor switch (when supplied)	125 v	3.5	30	5.0
	250 v	1.0	30	5.0

♦ infrequent operation

INSTALLATION

The relays should be mounted on switchboard panels or their equivalent in a location free from dirt, moisture, excessive vibration, and heat. Mount the relay vertically by means of the four mounting holes on the flange for semi-flush mounting or by means of the rear mounting stud or studs for projection mounting. Either a mounting stud or the mounting screws may be utilized for grounding the relay. The electrical con-

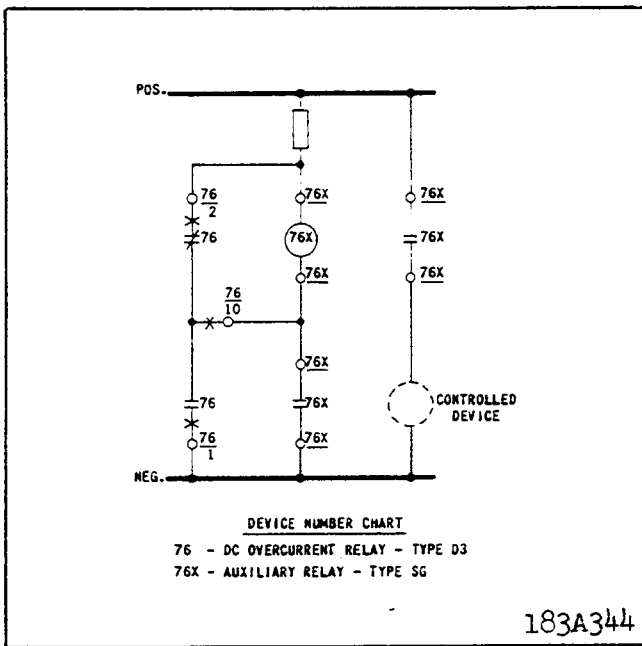

Fig. 5. External Schematic Diagram for Use of External Auxiliary Relay to Prevent Pumping of the Type D-3 Relay when used for Overload Protection.

nections may be made directly to the terminals by means of screws for steel panel mounting or to the terminal studs furnished with the relay for thick panel mounting. The terminal studs may be easily removed or inserted by locking two nuts on the stud and then turning the proper nut with a wrench.

For detailed FT case information refer to I.L. 41-076.

Standard D-3 relays are calibrated in millivolts measured at the relay terminals. Hence, the resistance of the leads between the relay and the ammeter shunt must be sufficiently low to avoid introducing an excessive error in the relay indication. With the 0-10 or 5-0-5 millivolt relays, leads 8 feet long of #10 B&S gauge copper wire will reduce the relay indication by approximately 5%. If the lead length is less or the conductor size is larger, the error will be correspondingly reduced. Relays with higher millivolt ranges have proportionally greater internal resistances, and consequently error due to lead resistance is reduced. For example, a 0-100 millivolt relay with leads as described above would have an error of 0.5% due to lead resistance.

The use of standard ammeter shunts may be avoided by connecting the moving element leads over an equivalent length of bus-bar or cable. On a basis

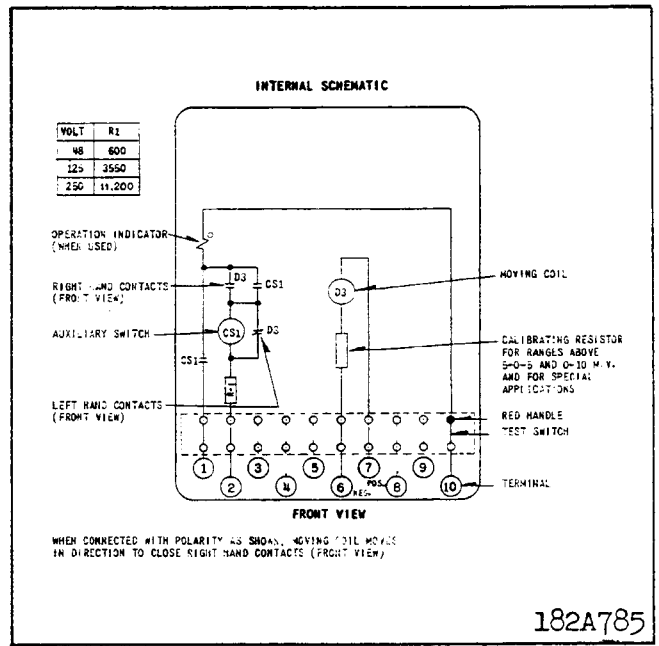

* Fig. 6. Internal Schematic of the Type D-3 Relay in the Type FT21 Case with Self-Contained Auxiliary Relay used to Prevent Pumping on Overload Protection.

of 1000 amp. per square inch, at 20°C., 6 feet of copper bus-bar will give 50 millivolts drop.

ADJUSTMENTS AND MAINTENANCE

The proper adjustments to insure correct operations have been made at the factory. Upon receipt of the relay, no customer adjustments, other than those covered under "Settings" should be required.

Acceptance Check

Check the scale markings by setting either of the two adjustable contacts at a value marked on the scale. Then alternately apply this voltage plus and minus 3%. The contacts should make and break.

Remove the adjustable contact from the setting and set the second adjustable contact at the same point on the scale. Alternately apply this voltage plus and minus 3%. The contacts should make and break.

Routine Maintenance

All contacts should be cleaned periodically. A contact burnisher S#182A836H01 is recommended for this purpose. The use of abrasive material for cleaning contacts is not recommended because of the danger of embedding small particles in the face of the soft silver and thus impairing the contact.

If the moving element should be removed, the bearing end-play should be checked when replacing it.

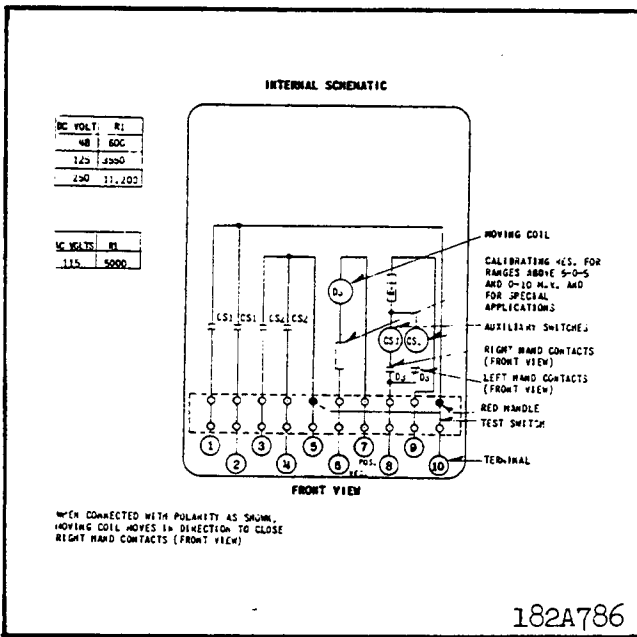

Fig. 7. Internal Schematic of the Type D-3 in the Type FT21 Case with Two Self-Contained Auxiliary Relays used to Increase Contact Capacity.

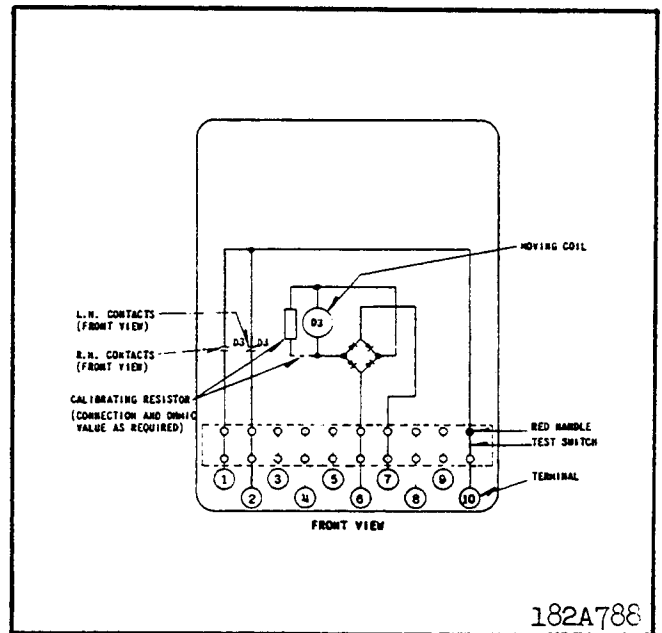

Fig. 8. Internal Schematic of the Type D-3 Relay in the Type FT21 Case, Modified for A-C Operation.

This should be from .020 inch to .025 inch, and can be measured by inserting a feeler gauge between the upper bearing screw and the shoulder on the moving element shaft.

The core and moving coil assembly should not be removed from the frame casting of the D-3 relay unless a keeper having the same radius on the core is placed on the core in such manner as to bridge the iron pole pieces as the core is withdrawn from the bore of the casting. It is necessary also to insert spacers in the air gap so that the core will remain approximately centered when the mounting screws are removed, to prevent damaging the coil winding when sliding the assembly out of the casting.

Auxiliary Switch (CS-1)

Adjust the stationary core of the switch for a clearance between the stationary core and the moving core when the switch is picked up. This can be done by turning the relay upside-down. Then screw up the core screw until the moving core starts rotating. Now back off the core screw until the moving core stops rotating. This indicates the points when the play in the assembly is taken up, and where the moving core just separates from the stationary core screw. Back off the core screw approximately one turn and lock in place. This prevents the moving core from striking

and sticking to the stationary core because of residual magnetism. Adjust the contact clearance for 3/64" by means of the two small nuts on either side of the Micarta disc.

Block main contacts closed and energize trip circuit with rated voltage. Contacts of auxiliary switch (CS-1) should make.

Operation Indicator

The operation indicator (when used) consists of a small solenoid coil mounted in a steel frame, a spring restrained armature and a white flag. The indicator is reset by a push rod in the cover. Block the CS-1 auxiliary relay contacts closed and pass 0.2 amperes AC or DC through the indicator. The white target should fall into view.

The coil has a dc resistance of approximately 2.8 * ohms and a continuous current carrying capacity of 0.6 amperes.

REPAIRS AND RENEWAL PARTS

Repair work can be done most satisfactorily at the factory. However, interchangeable parts can be furnished to the customers who are equipped for doing repair work. When ordering parts, always give the complete nameplate data.

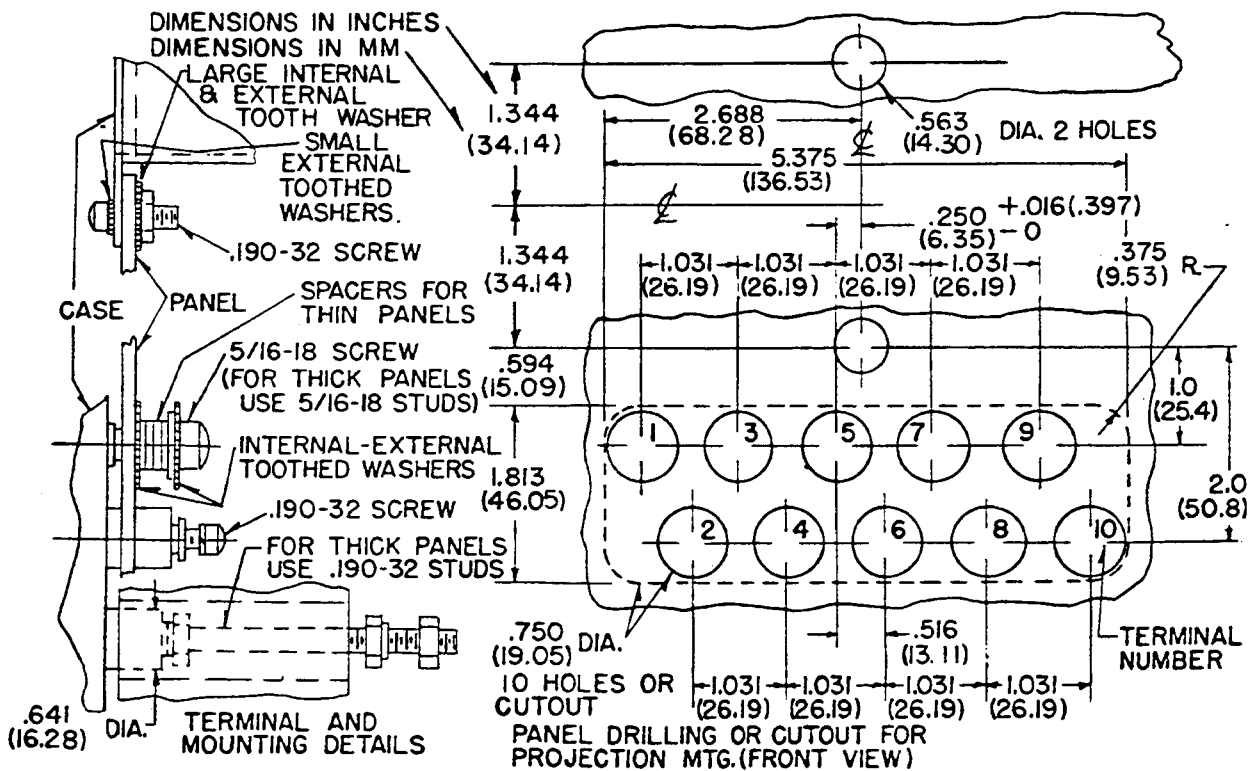
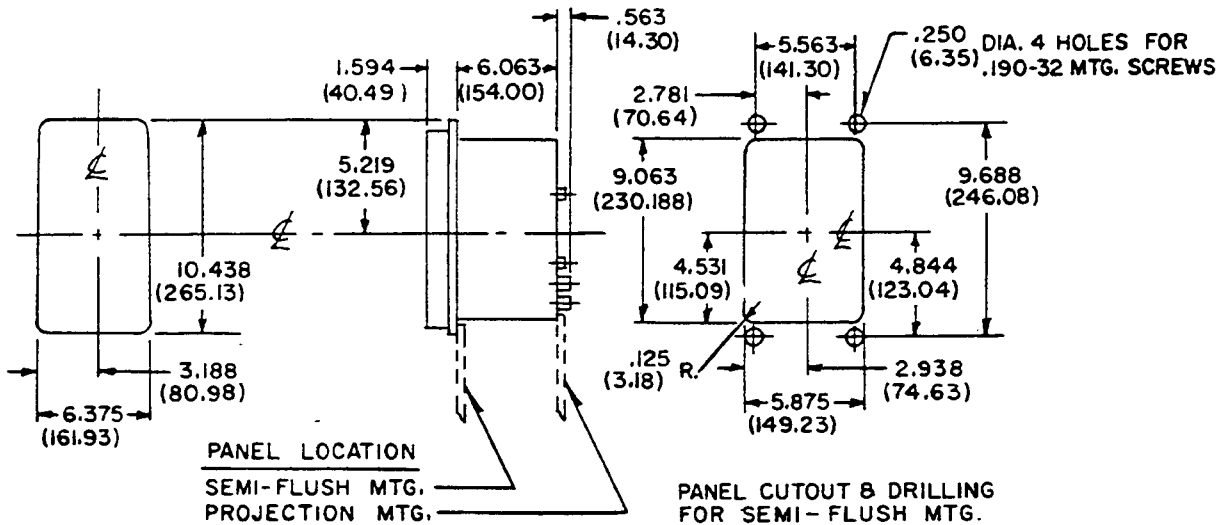

57D7901

Fig. 9. Outline and Drilling Plan for the Type D-3 Relay in the Type FT21 Case.

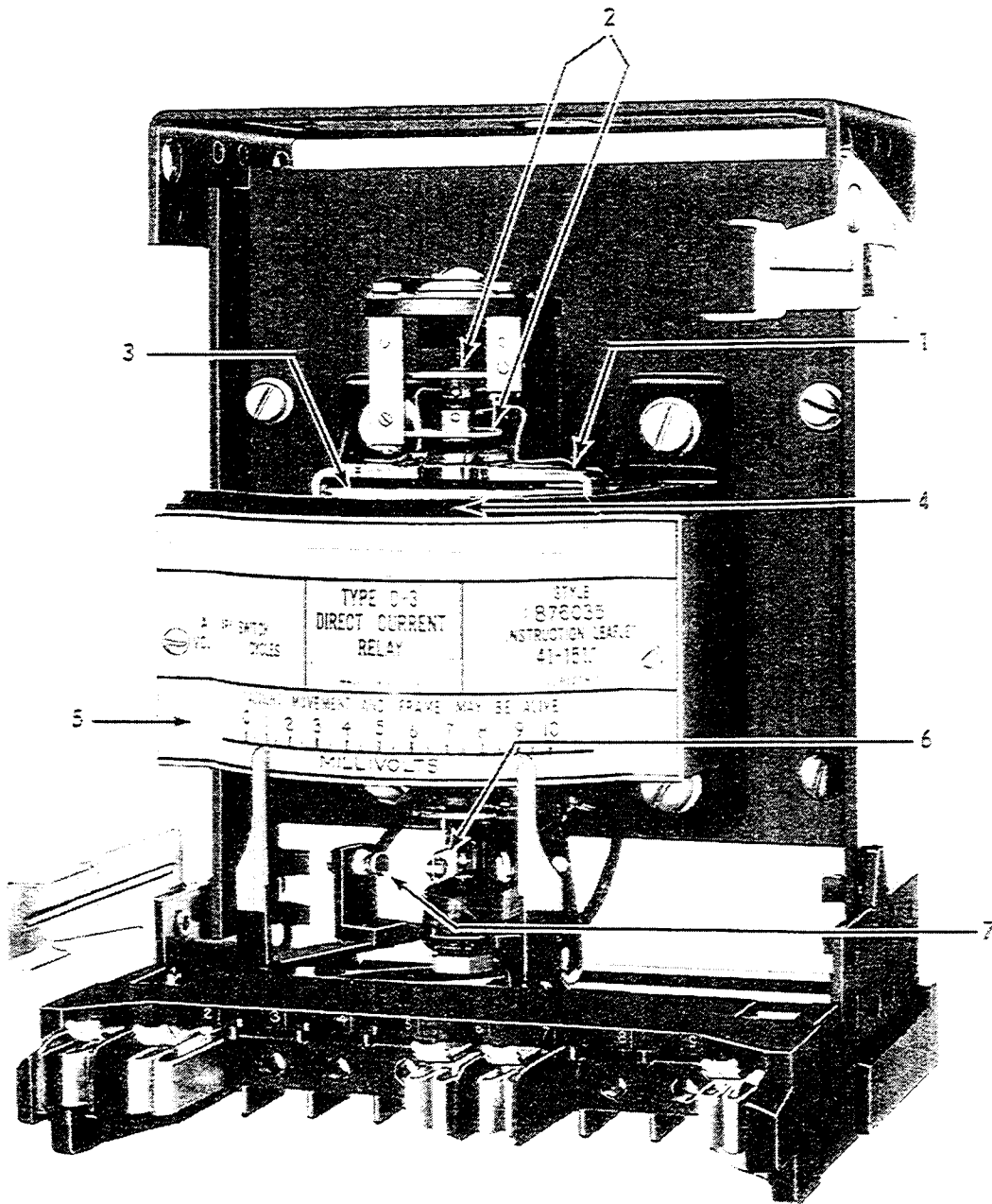

Fig. 10. Type D-3 Relay without Case. 1-Moving Coil. 2-Current-carrying restraining springs. 3-Permanent Magnet. 4-Iron-Frame. 5-Scale. 6-Moving Contact. 7-Stationary Contacts.