



# INSTALLATION • OPERATION • MAINTENANCE INSTRUCTIONS

## TYPE HZ, HZ-4 OR HZM PLATE-KEYED CARRIER RELAYING

### INTRODUCTION

The high-speed clearing of faults on transmission lines is recognized as necessary for good system operation. The best overall protection is provided by the method known as differential relaying in which conditions at the two ends of the line are compared to determine whether the fault is in the line section or external to the protected zone. This assures simultaneous tripping of the breakers, which is desirable from the stand points of stability, continuity of service, quick reclosing, and minimum damage to equipment. For many lines, carrier relaying is the most practical and reliable medium for comparing the conditions at two ends of the line.

This system of protection uses relays operating on current and voltage at each end of the line to detect and determine the direction of faults. Carrier is started by fault detectors when a fault occurs. Fault power flowing out of a line section indicates that the fault is external and the breakers should not be tripped. At the same instant, however, power will be flowing into the other end of the line as though the fault were in the section. Under this condition, the directional relays at the end where power is flowing out of the section will operate to continue the transmission of a carrier signal which is received at both ends and prevents the relays at both ends from tripping for all external faults. For internal faults, power will not be flowing out at either end and carrier will be stopped by operation of the directional elements at both ends to permit simultaneous tripping of both breakers.

The carrier scheme utilizes the time-

distance characteristics of the type HZ, HZ-4 or HZM relay to provide high speed simultaneous tripping with carrier in service, and step type distance protection with carrier either in or out of service. The first element of the type HZ, HZ-4 or HZM relay operated independently of carrier. The second element trips at high speed for faults in the section because the carrier tripping contacts short around the synchronous timer. These tripping contacts close immediately if the fault is within the section, but are held open by carrier to block tripping if the fault is beyond the section being protected. This arrangement thus provides simultaneous tripping over the entire line section. The synchronous timer is used in connection with the second impedance element to provide back-up protection for the second zone section. The tripping circuit of the third element is independent of carrier and operates with time delay for overall back-up protection. The directional element, supervised by the second impedance element, together with the third impedance element, control the transmission of carrier. Additional interlocks can be included to prevent tripping of any of the elements (carrier or back-up protection) due to out-of-synchronism surges. Thus, besides the carrier pilot protection, this system inherently provides high speed and time delay back-up protection.

### COMPONENTS OF COMPLETE EQUIPMENT

An outline of the equipment used at each terminal of a transmission line is as follows:

1. A set of relays, operating on the current and voltage of the line, to detect and determine the direction of faults, to trip the breaker if the fault falls within the zone of protection, and to control the transmission of carrier for external faults. One terminal of

SUPERSEDES I. L. 41-904

EFFECTIVE AUGUST 1955

\* Denotes change from superseded issue.

# CARRIER RELAYING

---

carrier relays consists of:

- \* 3 Type HZ impedance, HZ-4 Distance or HZM Distance Relays for phase faults.

1 Type HRK (current polarized) or Type HRP (Potential Polarized) Carrier Directional Overcurrent Ground Relay.

1 Type RS or RSN Carrier Auxiliary Relay.

1 Type CO, CR, CRC, CWC or CWP Ground Backup Relay.

- The type RSN relay with the Type HZ Relays
- \* provides out-of-synchronism blocking. The Type HZM Relays are usually set so that they do not operate on load or synchronizing surge swings from which the system can recover. Thus the Type HZM Relay with the Type RS Relay provides swing or synchronism surge blocking, but not out-of-step blocking without additional distance elements.

2. A d-c carrier transmitter-receiver set, the transmitter controlled by the fault detecting and directional relays, and the receiver to operate a receiver relay included in the Type RS or RSN relay. This is either the Type JY or the Type FD Carrier Set.

3. A coupling capacitor with carrier auxiliary for introducing the carrier frequency onto the transmission line. This may be supplied with a potential device for measuring line-to-ground potential or 3 sets can be used for measuring three phase line potential. The Carrier Coupling capacitor is the Type PC, and with the potential device, is usually the Type PCA.

4. A Line Coupling Tuner. This unit is used to tune out the capacitance of the coupling capacitor and match the transmitter or receiver circuits to the transmission line. The tuner is a part of the carrier set when the transmitter-receiver is mounted outdoors, or is separately mounted near the coupling capacitor when the transmitter-receiver is located indoors some distance from the tuner.

5. A Line trap to prevent short circuiting by the carrier transmitter output during a nearby external fault on the same phase wire

to which the carrier is coupled. These are usually the Type P or the Type M.

Similar equipment is required at each line terminal of the protected line section. Each line section is considered as a unit and should be assigned a different frequency to minimize the possibility of interference with other lines.

The transmitter-receiver sets are tuned to respond to the assigned frequency so that either receiver may receive a signal from the transmitter at the opposite end of the section. It is not necessary for the receiver to receive a signal from its own transmitter, since under this condition, the fault is external and the directional element contact blocks tripping. Therefore, it is possible on two terminal lines to use two frequencies in this carrier scheme and obtain two independent carrier channels for transmitting auxiliary functions in two directions simultaneously.

## OPERATION OF SCHEME

The ground relay and the type HZ impedance, type HZ-4 distance or type HZM distance relays are operated by current and voltage using the usual connections for these relays. For simplicity, the current and voltage circuits are not shown in the d-c simplified schematic diagrams of Figs. 1 and 2. The three impedance elements of these relays are set in the usual manner for step-type distance relaying except when Z3 is offset with the type HZ-4 or HZM relay. The first element Z1, is set for 80-90% of the line section and operates independently of carrier. The second element, Z2, is set for about 150% of the line section and so covers the entire line, but is particularly associated with that portion which is beyond the setting of the first element; that is, the last 20-10% of the line (end zone) adjacent to the next sectionalizing point. In this zone, it is not possible to determine by distance indication whether the fault is just within or just beyond the end of the section. For distance relaying, without carrier, a time delay contact T2, is used in series with the contact of the second zone impedance element to allow time

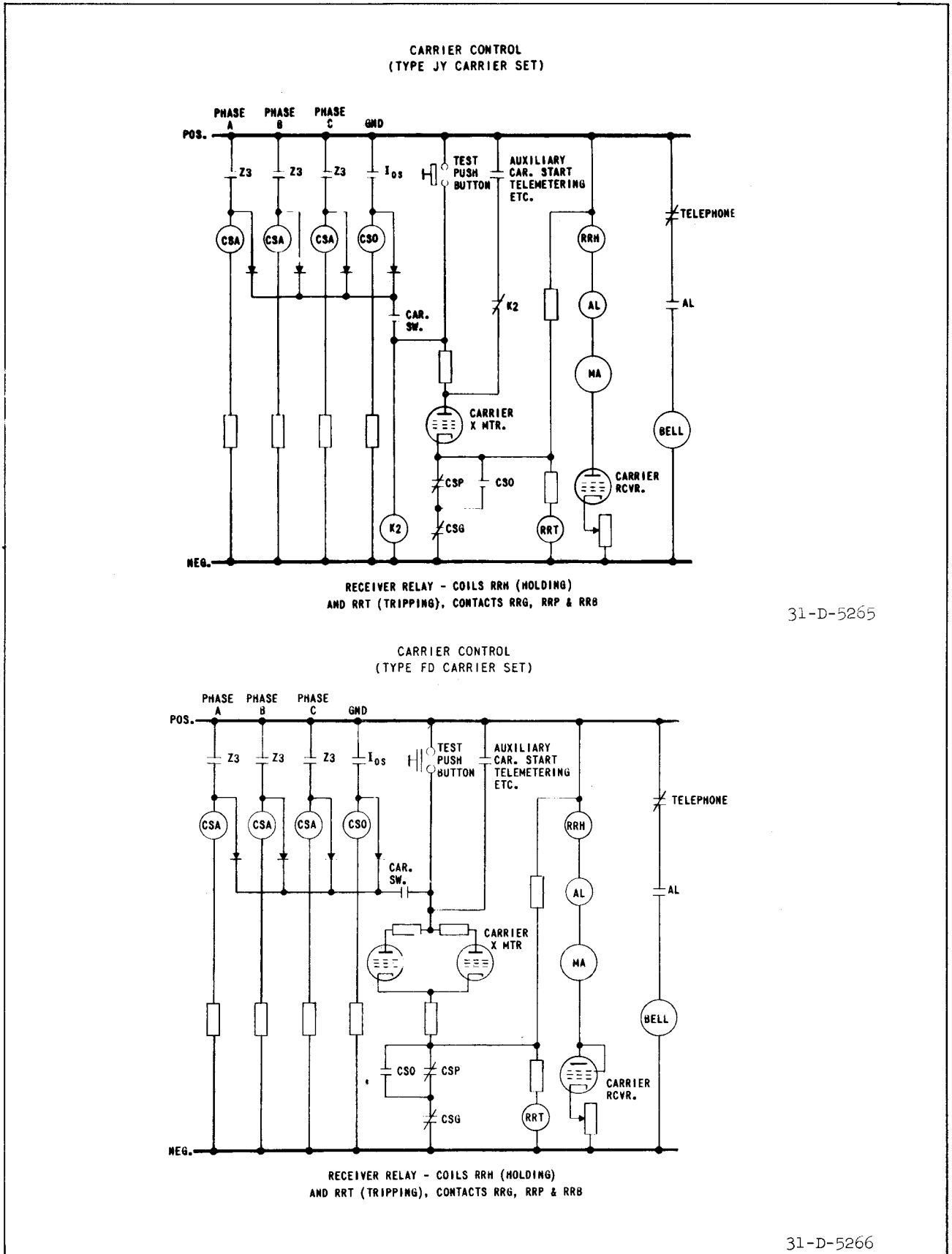

\* Fig. 1—Simplified D-C Schematic of the Carrier Control Circuits.

# CARRIER RELAYING

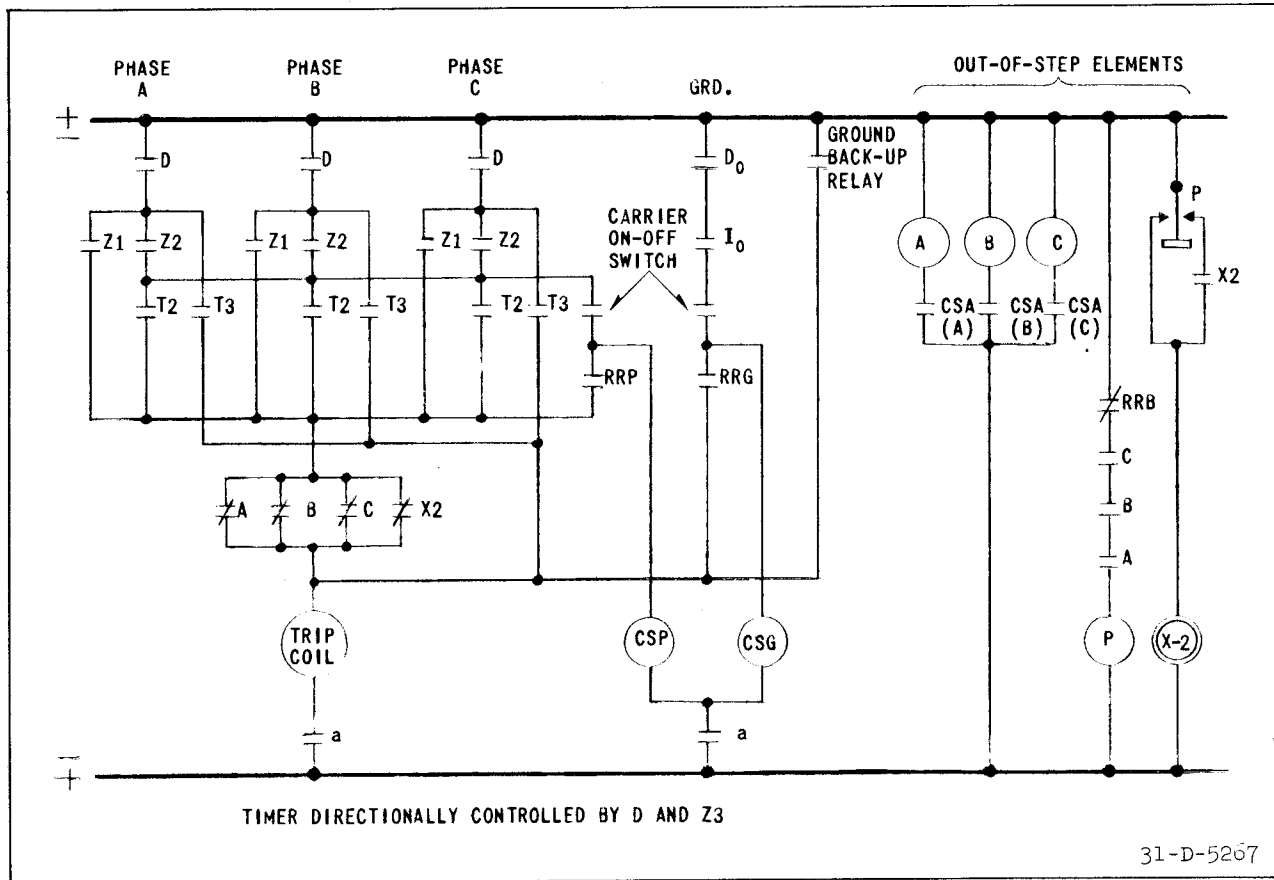

\* Fig. 2—Simplified D-C Schematic of the Trip Circuits.

for the breaker in the next section to clear. When used in carrier relaying, this T2 contact is paralleled by a contact, RRP, controlled by carrier, as explained below. The third element, Z3 of the Type HZ Relays, is given a distance setting to provide complete back-up protection through contact T3, and to start carrier transmission.

When the Z3 element of the Type HZ-4 or HZM Relay is offset to operate for internal faults, the element has directional characteristics and will not send blocking carrier for external faults. Consequently, in the Type HZ-4 or HZM Carrier scheme, it is necessary to reverse the Z3 element. This means that the third zone back-up protects the lines extending out of the station instead of the lines adjacent to the remote terminal breaker.

The synchronous timer motor is started by the directional and third element contacts in

series in the type HZ, HZ-4 and HZM relays except directional control is omitted when Z3 is reversed for Carrier when using the Type HZ-4 or HZM relays.

The Types HRK or HRP ground relays have a directional element and two instantaneous over-current elements. The operation of these elements is explained below.

The schematic carrier control and trip circuits are shown simplified in Figs. 1 and 2. The Type HZM, HZ-4 or HZ relay shown here has a single third impedance element contact and directional control of the timer. The same scheme also can be used with the older type HZ relays with two make and one break third impedance element contacts. With this latter type HZ relay the carrier control circuit is slightly different from that shown in Fig. 1. The trip circuits using either type HZ relay are basically the same as shown in Fig.2 as

far as carrier is concerned.

The upper diagram of Fig. 1 comprises the carrier control circuits when the type JY carrier set is used, and the lower diagram comprises the carrier control circuit when the type FD carrier set is used. The contacts Z3 (A, B, & C phases) in Fig. 1 serve to start the transmission of carrier for phase faults and contact IoS performs the same function for the ground faults. The ground start contact, IoS, is operated by an over-current element separate from that which operates the tripping contact.

Fig. 2 shows the trip circuits. The distance type trip paths are: First zone - D and Z1; Second zone - C, Z2 and T2, Third zone - D and T3. The carrier controlled tripping path is through D, Z2 and RRP contacts. For ground protection a carrier controlled trip circuit is set up through the contacts Do and Io of the ground relay and the carrier controlled contact RRG. The contact IoS is used to start carrier. The contacts, RRP and RRG, are on the blocking relay controlled by the carrier signal operating RRH and RRT coils.

Carrier is started by closing any one of the carrier start contacts Z3 or IoS, the carrier test push button, or the auxiliary carrier start contacts. These contacts connect the plate of the carrier oscillator tube to positive. The rectifier valves in the relaying carrier start circuit are to prevent the flow of current in the control circuit resistors which would unnecessarily load the carrier start contacts. The cathode of the oscillator tube is connected to negative through the back contacts CSP and CSG as shown in Fig. 1. Carrier stopping is controlled by the tripping contacts, D and Z2, for phase faults and Do and Io2 for ground faults. When fault power flows into the protected line section, the tripping contacts, D and Z2 close for phase faults and permit the coil of the auxiliary contactor switch, CSP, to be energized. This causes the back CSP contact in the carrier control circuits to open, which stops carrier by raising the cathode voltage above the operating value, and permits the RRT operating

coil of the receiver relay to be energized by the station battery.

Similarly, for ground faults Do and Io close to energize the coil of another auxiliary contactor switch, CSG, whose back contact, CSG, stops carrier and permits the operating coil of the receiver relay to be energized.

The arrangement of the carrier start and stop circuits is such that opening CSP and CSG contacts stop carrier regardless of how carrier is started. Thus relaying has preference at all times over all other uses of the carrier channel.

The circuits are arranged so that the action of the ground relay can be given preference over the phase relays. This is done by connecting the contacts CSO of the type RS or RSN relay around CSP carrier stop contacts as shown. This means that if IoS of the ground relay starts carrier, it is then impossible for the CSP contact and the phase relays to stop carrier. The purpose of this ground preference is to prevent possible incorrect indications of the phase relays due to load currents and the flow of positive and negative sequence currents during external ground faults.

The carrier controlled receiver relay is a sensitive polarized d-c relay provided with two make contacts, RRP and RRG, and one break contact, RRB. These contacts are operated by the action of two coils, one an operating coil, RRT, energized by the local battery and controlled as explained above by CSP and CSG contacts, and the other a carrier holding coil, RRH, connected in the plate circuit of the carrier receiving tube. Normally, both coils are de-energized and the make contacts, RRP and RRG, are held open by a magnetic bias. The relay is prevented from operating when the carrier holding coil, RRH, is energized even though the operating coil, RRT, is energized. This means that as long as carrier is being received either from the local transmitter or from the opposite end, RRH is energized and carrier tripping is prevented.

# CARRIER RELAYING

---

The complete sequence of events may be briefly summarized as follows: Assume an internal phase-to-phase fault just beyond the zone of one of the Z1 elements. Carrier will be initiated immediately at both ends of the line by the closure of one of the Z3 contacts. Meanwhile, the directional and second zone impedance contacts close and energize the auxiliary switch, CSP, stopping carrier and energizing the operating coil, RRT, of the carrier receiver relay. Since the same action has occurred at the far end of the line, no carrier is received and the contact, RRP, is closed at both ends completing the trip circuits through D and Z2. However, the trip coil at one end has already been energized through Z1. If the fault has been external to the section, then tripping could not have occurred since the carrier holding coil, RRH, would have been energized by carrier from the end nearest the fault where D would not be closed to stop carrier.

If an internal-two-phase-to-ground fault is assumed, the ground carrier start contact IoS, and one of the phase contacts will close to start carrier. If the ground preference contact is connected, then the operation of IoS will energize CSO and its contact will short out CSP thus making it impossible for the phase relays to stop carrier. However, the ground tripping contacts Do and Io2, will close energizing the CSG auxiliary relay to stop carrier.

It will be noted that carrier is not started at either end unless fault current operates a starting element (fault detector). This is significant in case a line becomes disconnected from a source of power at one end in other words, becomes a stub end feeder. If a fault occurs on such a line, the carrier transmitter will be started and stopped only at the end which is connected to the source of power and no carrier will be received from the other end to interfere with tripping.

On parallel lines, it is possible to have the fault power undergo a quick reversal as the breakers on the faulted line open. Under this condition, carrier transmission is maintained at one end until it has had time to be

started at the other.

It is desirable to check periodically the condition of the carrier set to determine its ability to send and receive a carrier signal. For this purpose a test push button is connected in parallel with the carrier start elements. Pressing the test push button sends a carrier signal which is received by the receiver tubes at both ends of the line section to operate an alarm relay and energize milliammeter. If the carrier set is not functioning, the alarm is not heard and the milliammeter does not deflect indicating trouble which must be investigated. The alarm relay has a minimum operating value in excess of the minimum required to operate the receiver relay so that an indication of impending trouble can be obtained before actual failure occurs.

A four-pole single-throw switch operated from a common handle is connected in the carrier control and carrier trip circuits, as shown in Figs. 1 and 2. The switch is marked "Carrier On-off" and opening it removes carrier supervision and permits the type HZ or HZM relays to operate in the conventional step-zone manner. The switch also removes the types HRK or HRP ground relay and ground protection is available through back-up ground relays.

## Out-of-Step-Protection

It is often desirable to prevent the operation of relays during out-of-step conditions so that the system can be separated at locations where synchronizing equipment is available. The carrier relaying system provides a means of preventing tripping during out-of-step conditions without impairing the ability to trip for internal faults occurring during out-of-step conditions. One fundamental difference between a three phase fault and an out-of-step condition is that a fault suddenly reduces the voltage and increases the current whereas during the approach of an out-of-step condition, the voltage and current changes are comparatively gradual.

The type HZM relays are usually set to oper-

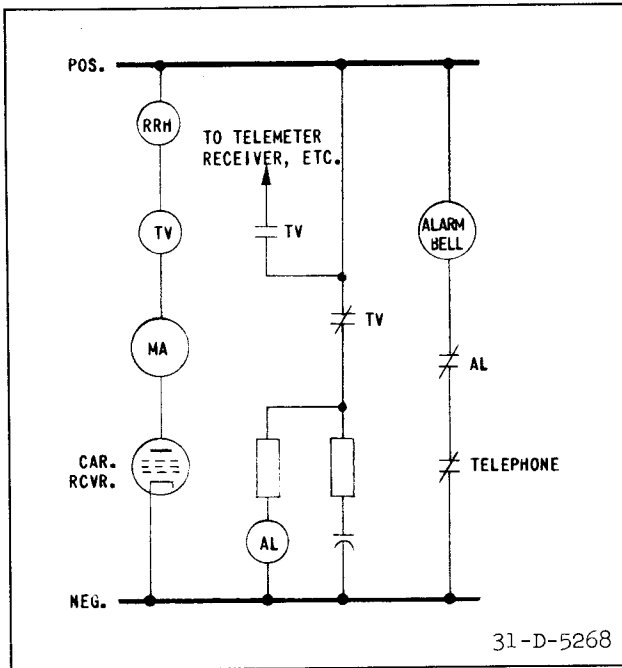

**\* Fig. 3—Time Delay Circuit for the Carrier Alarm when using the Carrier Channel for Telemetry or Supervisory.**

ate on faults, but not on load or synchronizing surge swings from which the system can recover. However, when the system goes out-of-step, the type HZM relays operate to separate the system. To provide out-of-step blocking in the Type HZM Carrier scheme, an additional blocking relay is required, such as the Type TSO-4 out-of-step blocking relay described in

\* I.L. 41-484.

In the type HZ Carrier scheme, out-of-step blocking is provided by using the type RSN relay instead of the type RS relay.

In this scheme, the distance elements all operate simultaneously for a three phase fault if they are to operate at all, while during out-of-step the Z3 operates first, followed by Z2 and then Z1. As the system returns toward the "in-phase" position, the elements reset the opposite order: that is, Z1, Z2, Z3.

To prevent tripping during out-of-step, it is necessary to arrange for the closure of the three contacts A, B, C, and for the receiver relay back contact, RRB, to operate an additional blocking relay to open the trip circuit.

This blocking relay must have a slight time-delay so that it does not open the trip circuit before tripping on a three phase fault can occur. On the other hand, it must open the trip circuit during an out-of-step condition before the second element, Z2 is operated.

The out-of-step blocking contact is designated as X2, and is connected in the trip circuit as shown in Figure 1. In parallel with it are three contacts, A, B, C, which are the back contacts on the auxiliary switches A, B, C, operated by the Z3 carrier starting contacts of the distance relays thru the auxiliary contactor switches, CSA, CSB, and CSC. The make contacts of these switches are in series with the back contact, RRB, of the receiver blocking relay, and energize the coil, P, of a pendulum type time-delay relay, whose lower contacts make and energize the coil of the X2 blocking relay. Every time that all three of the Z3 carrier start contacts close, the back contacts, A, B, C, and X2, open the trip circuit after a 3 to 4 cycle delay. Back contact X2, opens by virtue of all three make contacts, A, B, and C, closing through RRB to energize the P coil and in turn, the X2 coil.

If the electrical center is inside the protected line section, and in other cases where the two voltage sources appear 180° out of phase, the directional and impedance elements at each end of the line will be closed. This stops carrier (previously started by the Z3 contact).

This energizes RRT to allow the contact RRB to open. This de-energizes the pendulum relay, P, whose spring arm begins now to oscillate, alternately closing the bottom and top contacts, P. This keeps the X2 coil energized. After the amplitude of vibration of the pendulum has decreased to a certain value, it will not strike either of its contacts and X2 will reset. This action occurs in cycles, and the time delay introduced by the pendulum relay should be longer than the time during which both directional elements "point in" \*cycle" of the system. It is desirable to

## CARRIER RELAYING

---

clear internal faults occurring during an out-of-step condition, but it is not so essential to be able to clear them at high speed. The ground relay trip circuit is not blocked by the out-of-step relay, X2, and can trip instantly. On phase-to-phase faults, one or two of the Z3 contacts will reset when the system swings in phase, thus allowing one of the back contacts, A, B, or C to complete the trip circuit without waiting for the reset of X2. On a three phase fault, however, none of the Z3 contacts will reset, and consequently, tripping will not occur until after the expiration of the X2 time delay. The reset of X2 is made possible by the opening of the receiver relay back contacts, RRB.

It will be noted from Fig. 2 that the back-up tripping through D and T3 is not shown blocked by the out-of-step contacts. Therefore back-up protection is obtained on three-phase faults during out-of-step. If desired, it is arranged so that the T3 connection can be made on the other side of the out-of-step contacts in which case back-up protection on three-phase faults during out-of-step is not possible.

### ADDITIONAL CARRIER CHANNEL USES

In addition to the relaying described above, the carrier channel can be used for other functions such as telemetering, load control, communication and supervisory control. For these functions, suitable arrangements are made for keying the carrier transmitter by an auxiliary start contacts. As described previously, relaying has preference at all times.

In order to prevent the carrier alarm from ringing during the time carrier is being used for auxiliary telemetering function, the time delay circuit of Fig. 3 can be used at each terminal. This circuit consists of a combination of resistors and a capacitor energized thru contacts on an auxiliary type TV relay. When telemetering impulses are being sent or received, the coil of the type TV relay in the

receiver plate circuit is energized on each impulse. This causes the normally closed contact, TV, to alternately open and close energizing the circuit thru a resistor and a capacitor. In parallel with this capacitor, is a circuit consisting of a resistor and a coil AL of the carrier alarm element. The resistors and capacitors are chosen so that for this particular case a maximum delay of approximately 2 seconds can be obtained. This will prevent operation on the longest telemetering impulse.

If it is desired to signal by means of the push button, it is only necessary to hold the push button closed for a period long enough to cause the alarm element to drop out. Energizing carrier thru the push button maintains the normally closed contact, TV, open and when the charge on the capacitor is used up, the alarm element will drop out, closing its back contact marked "alarm" and causing the bell to sound. By properly proportioning the resistor and capacitor, a wide range of drop-out times can be obtained for the alarm element.

The alarm bell can be made to operate instantaneously whenever the relays start carrier by using the type PG relay connected in the carrier relay start circuit with its back contact in the alarm coil circuit.

Emergency point-to-point communication is normally supplied with the carrier relaying equipment. This can be done by plugging a handset at the carrier set, at the relay switchboard, or from a desk set permanently wired to the equipment. The push-to-talk type of communication is employed where the operator pushed a switch on the handset to start carrier and connect the microphone to the carrier transmitter. During the listening period, the operator releases the switch. Whenever the handset is plugged in or lifted from the desk stand, the carrier alarm circuit is opened to prevent ringing during conversation. This alarm circuit is used for code ringing.

**WESTINGHOUSE ELECTRIC CORPORATION**  
**METER DIVISION** **NEWARK, N.J.**