



# INSTALLATION • OPERATION • MAINTENANCE INSTRUCTIONS

## TYPE TD TIMING RELAY

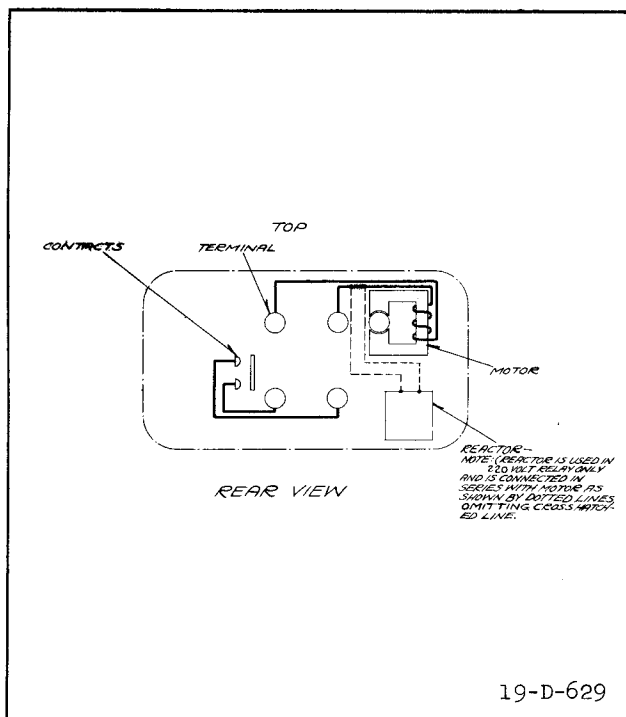

Fig. 1—Internal Connections of Four-Terminal Type TD Relay.

**CAUTION** Before putting relays into service, remove all blocking which may have been inserted for the purpose of securing the parts during shipment, make sure that all moving parts operate freely, inspect the contacts to see that they are clean and close properly, and operate the relay to check the settings and electrical connections.

### APPLICATION

Westinghouse type TD relay is an a-c. relay suitable for applications which require a time-delay of from five seconds to three minutes between the closing of an a-c. circuit and the closing or opening of a second circuit, either a-c. or d-c., through the contacts of the re-

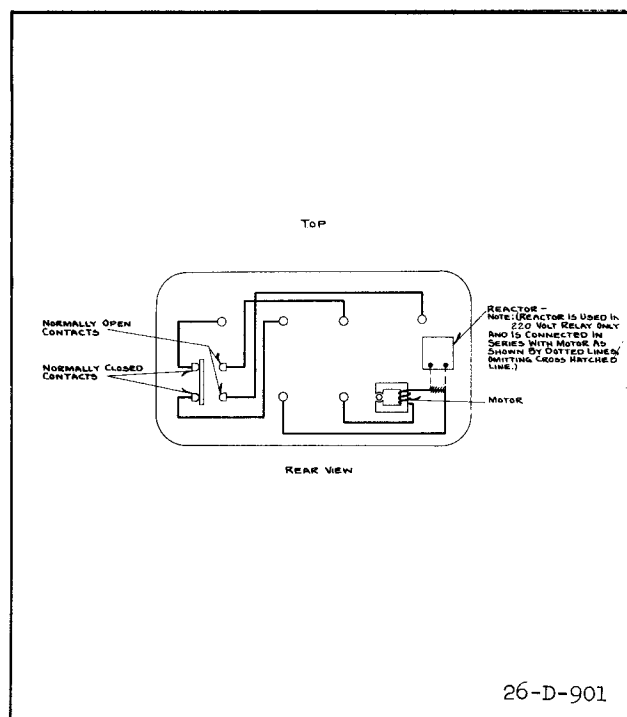

Fig. 2—Internal Connections of Six-Terminal Type TD Relay.

lay. Many such applications are found in automatic control circuits for generators and motors, in connection with the operation of large rectifier and other thermionic tubes, and in various types of industrial control.

Compared to the type TK relay, the type TD relay is recommended for comparatively shorter delay times, with a maximum of 3 minutes. Where circuit-opening features are needed the type TK relay should usually be used.

### INSTALLATION

The relay should be mounted with its long dimension horizontal, so that the gear shafts

## TYPE TD TIMING RELAY

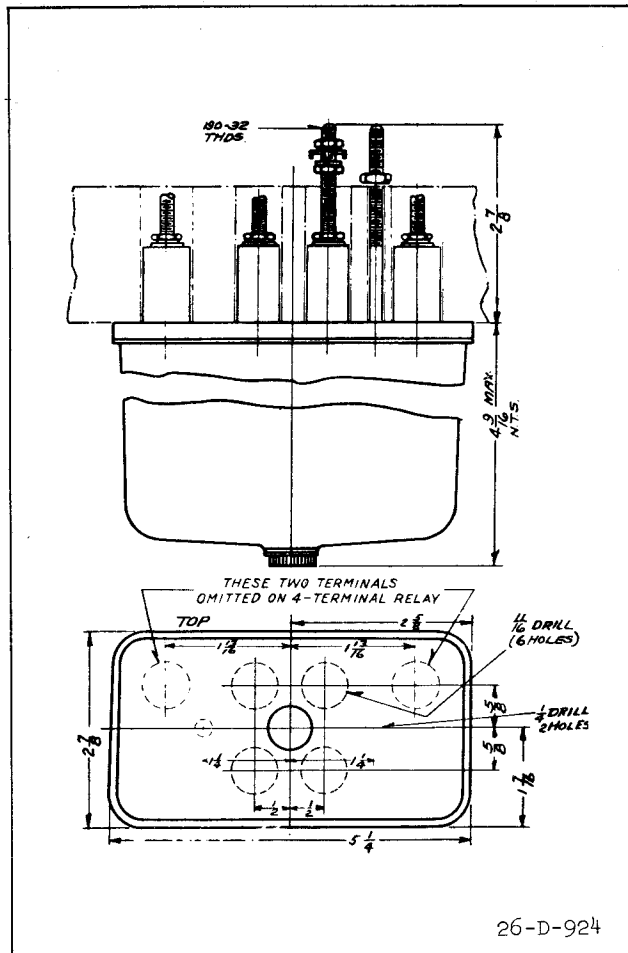

Fig. 3—Outline and Drilling Dimensions of Type TD Relay.

are vertical and the motor terminals are at the top. It will not operate properly if mounted in any other position. If the circuit to which the motor of the relay is connected has a voltage higher than 240 volts a-c., an external resistor is supplied with the relay. This should be mounted near the relay and connected in series with the motor circuit.

### CONSTRUCTION AND OPERATION

The type TD relay consists of a small 600 r.p.m. self-starting synchronous motor, a gear train, and a set of silver contacts of the bridging type. When the motor is de-energized the rotor rests in a position somewhat lower than the pole pieces of the stator. In this position the pinion on the rotor shaft is out of mesh with the gear on the countershaft which is mounted in the motor frame. When the

motor is energized, the rotor is lifted by magnetic attraction and the pinion is brought into mesh with the gear. The pinion on the motor countershaft drives a train of three reduction gears. An arm pressed on the shaft of the last gear is used to operate the contacts. When the motor has operated to open or close the relay contacts, the arm on the last shaft strikes a stop and the motor stalls. However, the motor can remain connected to the line without injury when stalled, and the locked rotor torque provides very good pressure on the closed contacts.

A spiral spring fastened to the shaft of the last gear causes the arm to reset to its initial position when the motor is de-energized. Since the pinion on the rotor shaft drops out of mesh when the motor is de-energized, the gear train ratio is reduced and the control spring will reset the arm very quickly. The resetting time for maximum time-delay is less than 5% of the operating time. Because of the inertia of the gear train the resetting time is not directly proportional to the operating time. Consequently, with a time-delay setting of about one scale division the resetting time may be about 10% of the closing time.

An adjustable backstop for the arm on the last gear shaft is clamped between the upper bearing plate of the gear train assembly and the bearing screw for the last shaft. A scale on the upper bearing plate is used in conjunction with an index line on the Micarta portion of the arm when it is desired to make an approximate setting of the relay. For the style most generally used the motor will drive the arm over the entire scale travel in approximately 1.5 minutes. Thus each of the ten small scale divisions corresponds to approximately 9 seconds. Where a very accurate setting is desired, the time interval should be checked with a stop watch and the position of the backstop adjusted for the exact time required. The backstop should be clamped securely by means of the bearing screw after the desired setting is obtained.

For special applications which require a longer time-delay than 1.5 minutes, the TD relay can be supplied with a maximum delay of

approximately three minutes. This is accomplished by a change in the gearing of the motor only. The two styles of relays are identical in other respects.

The TD relay can be supplied with several different contact arrangements. The contacts themselves are made of chemically pure silver. The four-terminal relay can be furnished with bridging contacts which are either opened or closed at the end of the time-delay. The six-terminal relay has one set of contacts which are opened after a time-delay and a second set which are closed a few seconds later. In this case a silver strip which is held bridged across the normally closed contacts by a spring is moved away from these contacts by the arm on the last gear shaft and is forced against the normally-open contacts. Therefore, the transition is not instantaneous, but depends upon the spacing between the two sets of contacts and upon the gear ratio. The spacing between the contacts can be varied a small amount by adding or removing washers between the heads of the contact screws and the mounting blocks.

The minimum time-delay obtainable with the TD relay with normally-open contacts only depends entirely on the minimum contact gap permissible. If the backstop is set so that the contact arm is one-half of a scale division from the contact-closed position, the contact gap will be approximately 1/16" and the time-delay will be about 4.5 seconds for the 1.5 minute relay. Because of the bridging type of contact used, there are two gaps in series in the contact circuit, and the total gap in this case would be about 1/8". If the contacts are required to break only a small amount of current when the motor circuit is de-energized, the time-delay may be decreased by a further reduction in the contact gap.

The normally-open contacts of the type TD relay can be used to close circuits carrying as much as 10 amperes at 125 volts, either a-c. or d-c. They will open such a circuit satisfactorily if a-c., but should not be used to open a d-c. circuit carrying more than 1.5 amperes at 125 volts. The normally-closed contacts have less contact pressure than the normally-open contacts and should not be used to carry more than 5 amperes. Because they open slowly, they should not be required to break more than 2.5 amperes at 125 volts a-c. or 0.5 ampere at 125 volts d-c.

### \* ENERGY REQUIREMENTS

The motor current is approximately 23 milli-amperes at 120 volts for a 60 cycle burden of 2.75 V.A.

### MAINTENANCE AND RENEWAL PARTS

All contacts should be periodically cleaned with a fine file. S#1002110 file is recommended for this purpose. The use of abrasive material for cleaning contacts is not recommended, because of the danger of embedding small particles in the face of the soft silver and thus impairing the contact.

Repair work can be done most satisfactorily at the factory. However, interchangeable parts can be furnished to the customers who are equipped for doing repair work. When ordering parts, always give the complete name-plate data.

In case the synchronous motor should be damaged, the relay should be returned to our Works for repair, or a complete replacement motor should be installed.



**WESTINGHOUSE ELECTRIC CORPORATION**  
**METER DIVISION**

**NEWARK, N.J.**

Printed in U.S.A.