**INSTALLATION • OPERATION • MAINTENANCE
I N S T R U C T I O N S****TYPES KD AND KD-1
COMPENSATOR DISTANCE RELAYS****TABLE OF CONTENTS**

	Page		Page
APPLICATION	3	R_B Settings	18
CONSTRUCTION	3	Line Angle Adjustment	18
Compensator	3	Indicating Contactor Switch	18
Auto-Transformer	3	INSTALLATION	21
Tripping Unit	4	EXTERNAL CONNECTIONS	21
Indicating Contactor Switch Unit (ICS) ..	5	RECEIVING ACCEPTANCE	23
OPERATION	5	Distance Units	23
Three Phase Unit	8	Indicating Contactor Switch (ICS)	23
Phase-to-Phase Unit	8	ROUTINE MAINTENANCE	23
CHARACTERISTICS		Distance Units	23
Distance Characteristic: Phase-to-Phase Unit	9	Indicating Contactor Switch	24
Sensitivity Phase-to-Phase Unit	10	REPAIR CALIBRATION	24
Distance Characteristic: KD, 3 Phase Unit	11	Auto-Transformer Check	24
Sensitivity: KD, 3 Phase Unit	11	Distance Unit Calibration	24
Distance Characteristic: KD-1 3 Phase Unit	11	I. Three Phase Unit	24
Sensitivity: KD-1 3 Phase Unit	13	II. Phase-to-Phase Unit	25
General Characteristics	13	III. Compensator Check	27
TIME CURVES AND BURDEN DATA	13	IV. Overall Check	27
Operating Time	13	NOMENCLATURE FOR RELAY	
Current Circuit Rating in Amperes	13	TYPES KD AND KD-1	30
Burden	13	SWITCHBOARD TESTING WITH KD	
Trip Circuit Constants	13	AND KD-1 RELAYS	32
SETTING CALCULATIONS	16	Potential Circuit Check	32
SETTING THE RELAY	16	Current Verification	32
Compensators (T, T _A , T _B , and T _C)	18	Current Identification	32
Auto-Transformer Primary (S, S _A , and S _C) ..	18		
Auto-Transformer Secondary (M, M _A , and M _C)	18		

Supersedes I.L. 41-491F

* Denotes change from superseded issue.

EFFECTIVE OCTOBER 1964

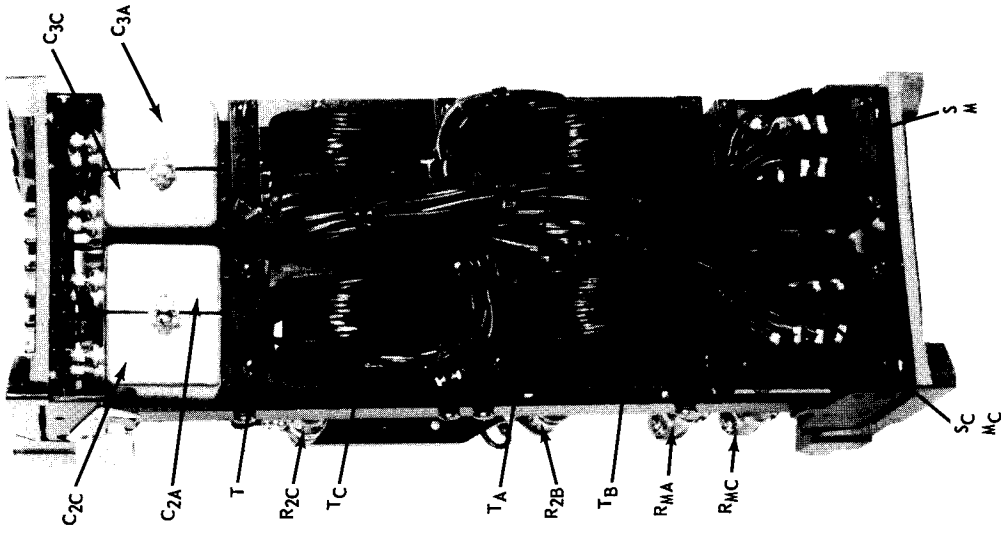

KD & KD-1 Relays

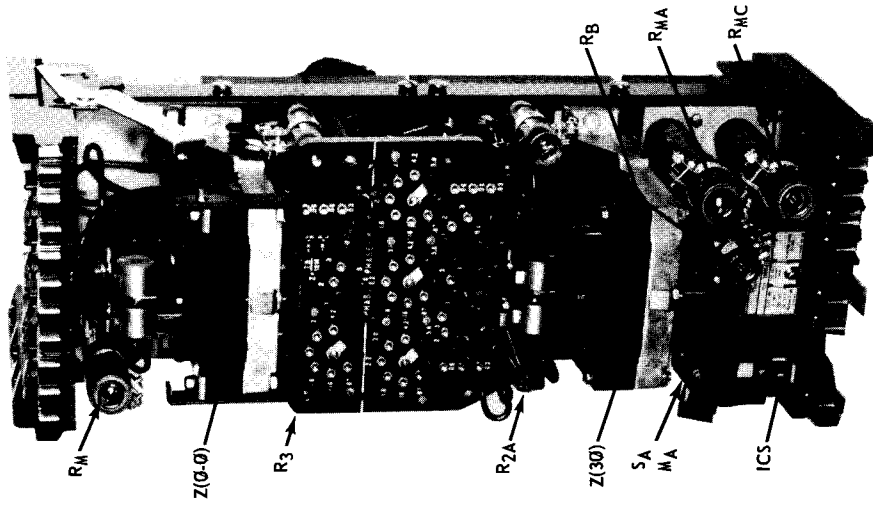

KD-1 Relay

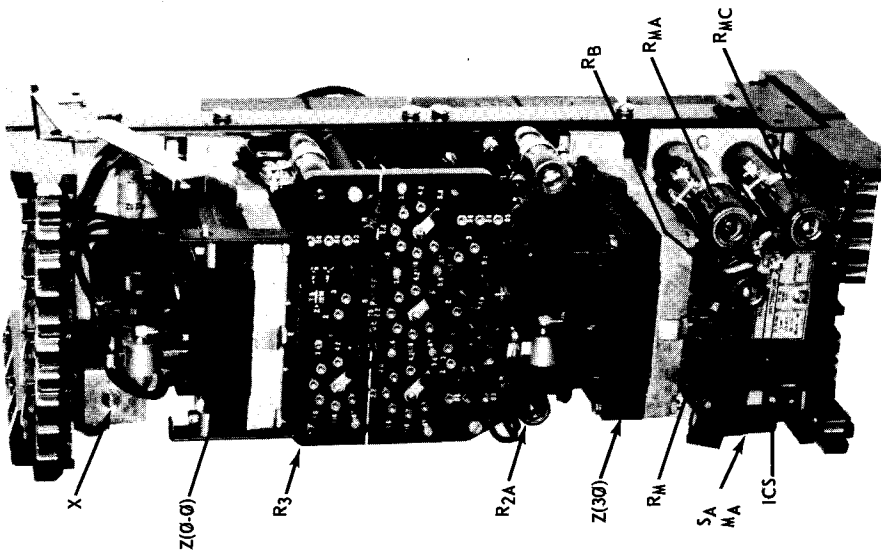

KD Relay

Fig. 1. Type KD & KD-1 Relays Without Case.

CAUTION: Before putting protective relays into service make sure that all moving parts operate freely, inspect the contacts to see that they are clean and close properly, and operate the relay to check the settings and electrical connections.

APPLICATION

The type KD relay (Figure 1), is a polyphase compensator type relay which provides a single zone of phase protection for all three phases. It provides instantaneous tripping for all combinations of phase-to-phase faults, two-phase-to-ground faults, and three-phase faults.

The type KD-1 relay, (Figure 1), is similar to the KD relay except that its characteristic impedance circle includes the origin. This relay is applied as a third zone of protection in pilot relaying schemes but it may also be used for time delay tripping in straight distance relaying.

Both the KD and KD-1 are available with indicating contactor switches with either a 1 ampere or a 0.2/2.0 ampere rating. The 1 ampere rating is recommended for all directional comparison applications and for most distance relaying applications. The 0.2/2.0 ampere rating is recommended for distance relaying where a lockout relay is energized or where a high impedance auxiliary tripping relay is utilized.

Refer to I.L. 41-911 for a description of how KD & KD-1 relays are used in directional comparison blocking systems.

For time-distance applications the KD & KD-1 relays are used with either the TD-2 a-c current-operated timer, or with the TD-4 d-c transistorized timer. See Figs. 17 and 18 for the external schematics for 3 zone protection, using the TD-2 and TD-4 relays, respectively. For further discussion see "External Connections."

- * Use fault detectors to supervise the trip circuit for those applications where the relays can be de-energized without attendant opening of the 52a contact. Otherwise undesired tripping occurs. A S#1878395 three unit SC Relay (2-8 amperes) in the type FT32 case or a S#288B714A18 three unit ITH Relay (4-8 amperes) in the type FT11 case is recommended.

CONSTRUCTION

The types KD and KD-1 relays each consist of

four single air gap transformers (compensators), three tapped auto-transformers, two cylinder type operating units, and an ICS indicating contactor switch. The KD relay also contains an adjustable reactor not used in the KD-1.

Compensator

The compensators which are designated T, T_A, T_B, and T_C are two-winding air-gap transformers (Figure 2). The primary, or current winding, has seven taps which terminate at the tap block, (Figure 3). They are marked .87, 1.16, 1.6, 2.2, 3.0, 4.2, and 5.8. Current flowing through the primary coil provides an MMF which produces magnetic lines of flux in the core.

A voltage is induced in the secondary which is proportional to the primary tap and current magnitude. This proportionality is established by the cross sectional area of the laminated steel core, the length of an air gap which is located in the center of the coil, and the tightness of the laminations. All of these factors which influence the secondary voltage proportionality have been precisely set at the factory. The clamps which hold the laminations should not be disturbed by either tightening or loosening the clamp screws.

The secondary winding has a single tap which divides the winding into two sections. One section is connected subtractively in series with the relay terminal voltage. Thus a voltage which is proportional to the line current is subtracted vectorially from the relay terminal voltage. The second section is connected to an adjustable loading resistor and provides a means of adjusting the phase angle relation between primary current and the induced secondary voltage. The phase angle may be set for any value between 60° and 80° by adjusting the resistor between its minimum and maximum values respectively or for 89° by open circuiting the resistor. The factory setting is for a maximum torque angle of 75° current lagging voltage.

Auto-Transformer

The auto-transformer has three taps on its main winding, S, which are numbered 1, 2, and 3 on the tap block. A tertiary winding M has four taps which may be connected additively or subtractively to inversely modify the S setting by any value from -15 to + 15 percent in steps of 3 percent.

The sign of M is negative when the R lead is above the L lead. M is positive when L is in a tap

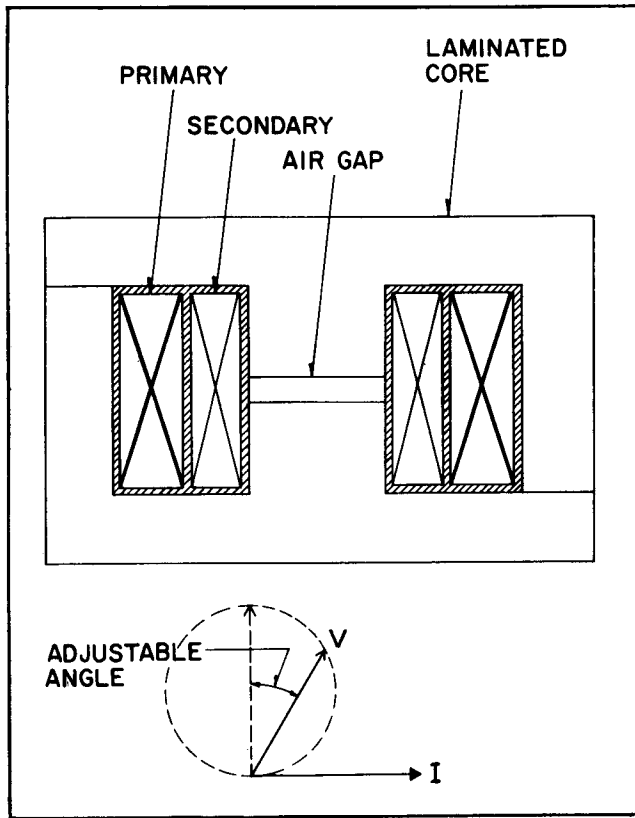

Fig. 2. Compensator Construction.

location which is above the tap location of the R lead. The M setting is determined by the sum of per unit values between the R and L lead. The actual per unit values which appear on the tap plate between taps are 0, .03, .06, and .06.

The auto-transformer makes it possible to expand the basic range ($T = 0.87$ to 5.8 ohms) by a multiplier of $\frac{S}{1 \pm M}$. Therefore, any relay ohm setting can be made within ± 1.5 percent from 0.75 ohms to 20 ohms by combining the compensator taps T , T_A , T_B , and T_C with the auto-transformer taps S and M , S_A and M_A , and S_C and M_C .

Tripping Unit

The device which acts to initiate tripping is a four-pole cylinder unit which is connected open delta and operates as a three-phase induction motor. Contact-closing torque is produced by the unit when the voltage applied to its terminals has a negative-phase sequence. Closing torque for the relay forces the moving contact to the left hand side as viewed from the front of the relay. Contact-opening torque is produced when positive-phase sequence voltages are applied. Hence, the cylinder unit has restraint or operating torque as determined by the phase sequence of the voltages applied to its terminals.

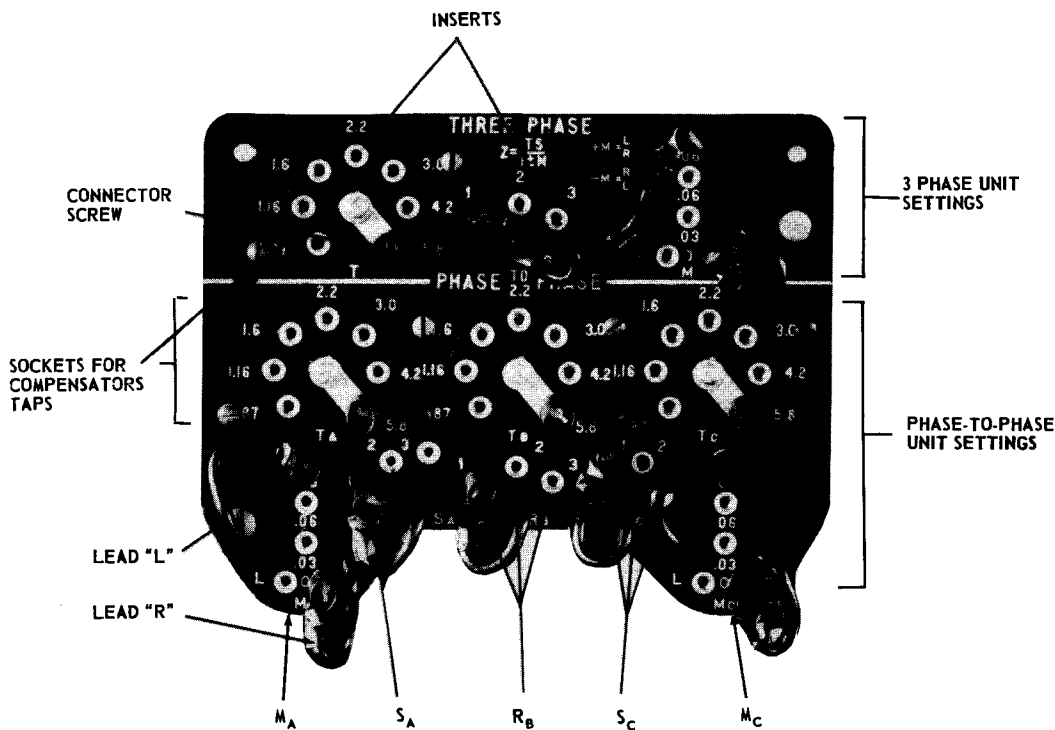

Fig. 3. Tap Plate.

Mechanically, the cylinder unit is composed of four basic components: a die-cast aluminum frame, an electromagnet, a moving element assembly, and a molded bridge.

The frame serves as the mounting structure for the magnetic core. The magnetic core which houses the lower pin bearing is secured to the frame by a locking nut. In the KD relay only, the core of the three-phase (lower) unit is secured to the frame by a spring and snap ring. This is an adjustable core which has a .025 inch flat on one side and is held in its adjusted position by the clamping action of two compressed springs. The bearing can be replaced, if necessary, without having to remove the magnetic core from the frame.

The electromagnet has two series-connected coils mounted diametrically opposite one another to excite each set of poles. In the KD-1 relay only, the three-phase (lower) unit has a single turn of heavy wire around one of its poles. This single turn carries the compensator primary current and provides a means of obtaining contact closing torque with current only. Locating pins on the electromagnet are used to accurately position the lower pin bearing, which is mounted on the frame, with respect to the upper pin bearing, which is threaded into the bridge. The electromagnet is secured to the frame by four mounting screws.

The moving element assembly consists of a spiral spring, contact carrying member, and an aluminum cylinder assembled to a molded hub which holds the shaft. The hub to which the moving-contact arm is clamped has a wedge-and-cam construction, to provide low-bounce contact action. A casual inspection of the assembly might lead one to think that the contact arm bracket does not clamp on the hub as tightly as it should. However, this adjustment is accurately made at the factory and is locked in place with a lock nut and should not be changed.

Optimum contact action is obtained when a force of 4 to 10 grams pressure applied to the face of the moving contact will make the arm slip one-fourth of its total free travel. Free travel is the angle through which the hub will slip from the condition of reset to the point where the clamp projection begins to ride up on the wedge. The free travel can vary between 15° to 20°.

The shaft has removable top and bottom jewel bearing. The shaft rides between the bottom pin bearing and the upper pin bearing which is adjusted

to .025 inch from the top of the shaft bearing. The cylinder rotates in an air gap formed by the electromagnet and the magnetic core.

The bridge is secured to the electromagnet and frame by two mounting screws. In addition to holding the upper pin bearing, the bridge is used for mounting the adjustable stationary contact housing. This stationary contact has .002 to .006 inch follow which is set at the factory by means of the adjusting screw. After the adjustment is made the screw is sealed in position with a material which flows around the threads and then solidifies. The stationary contact housing is held in position by a spring type clamp. The spring adjuster is located on the underside of the bridge and is attached to the moving contact arm by a spiral spring. The spring adjuster is also held in place by a spring type clamp.

When the contacts close, the electrical connection is made through the stationary contact housing clamp, to the moving contact, through the spiral spring and out to the spring adjuster clamp.

Indicating Contactor Switch Unit (ICS)

The indicating contactor switch is a small d-c operated clapper type device. A magnetic armature, to which the leaf-spring mounted contacts are attached, is attracted to the magnetic core upon energization of the switch. When the switch closes, the moving contacts bridge two stationary contacts, completing the trip circuit. Also during this operation two fingers on the armature deflect a spring located on the front of the switch, which allows the operation indicator target to drop. The target is reset from outside of the case by a push rod located at the bottom of the cover.

The front spring, in addition to holding the target, provides restraint for the armature and thus controls the pickup value of the switch.

OPERATION

Each KD or KD-1 relay has two major components compensators and tripping units. In the internal schematics of Figs. 4 & 5 the compensators are designated T, T_A, T_B and T_C; the tripping units, Z (3Ø) & Z (ØØ). The phase-to-phase unit Z (ØØ) operates for all combinations of phase-to-phase faults (phase 1-2, 2-3 & 3-1). The 3 phase unit Z (3Ø) operates for 3 phase faults and for close-in two-phase-to-ground faults, although most two-phase-to-ground faults are cleared by operation of the phase-to-phase unit. Each of the tripping units and its associated compensator circuit are electrically separate, and will

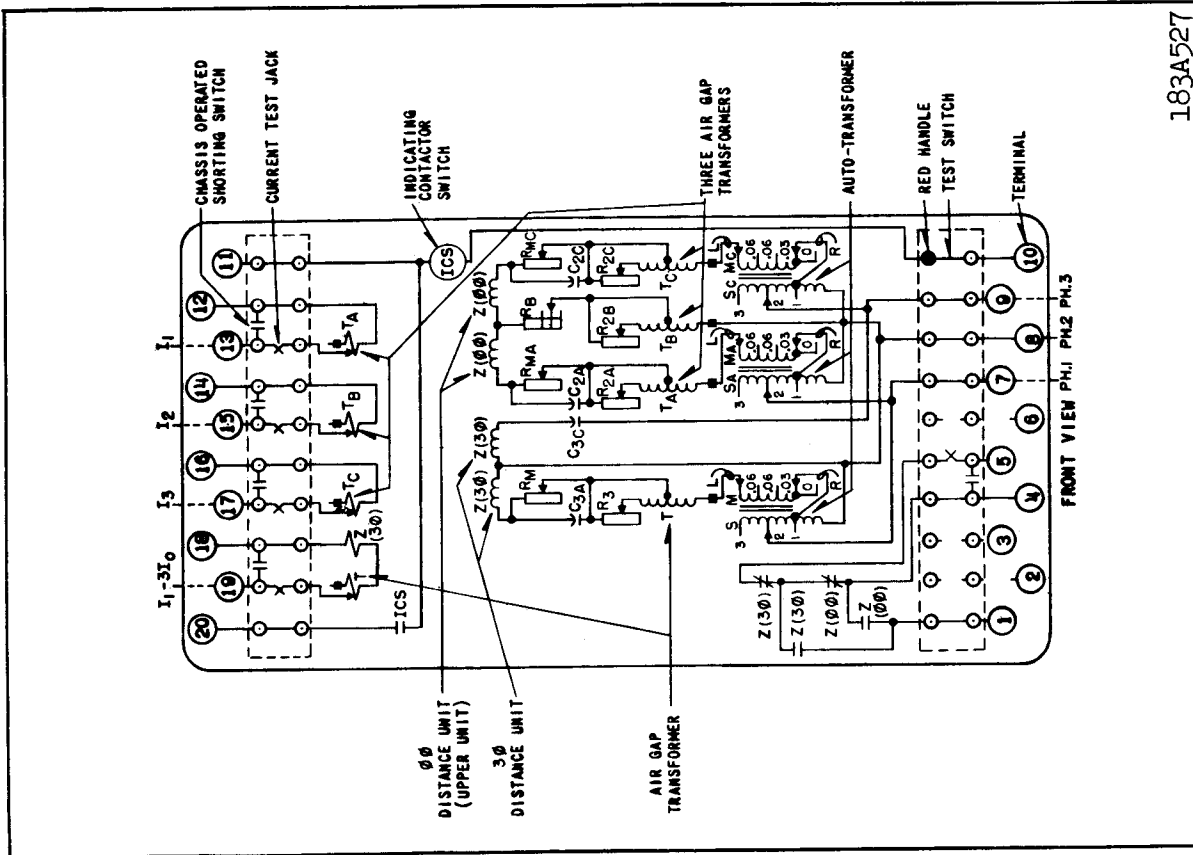

Fig. 5. Internal Schematic of Type KD-1 Relay with 1.0 ampere I.C.S. in the Type FT42 Case. (Relay with 0.2/2.0 ampere I.C.S. unit has identical wiring except that the I.C.S. coil is tapped on terminal 10.)

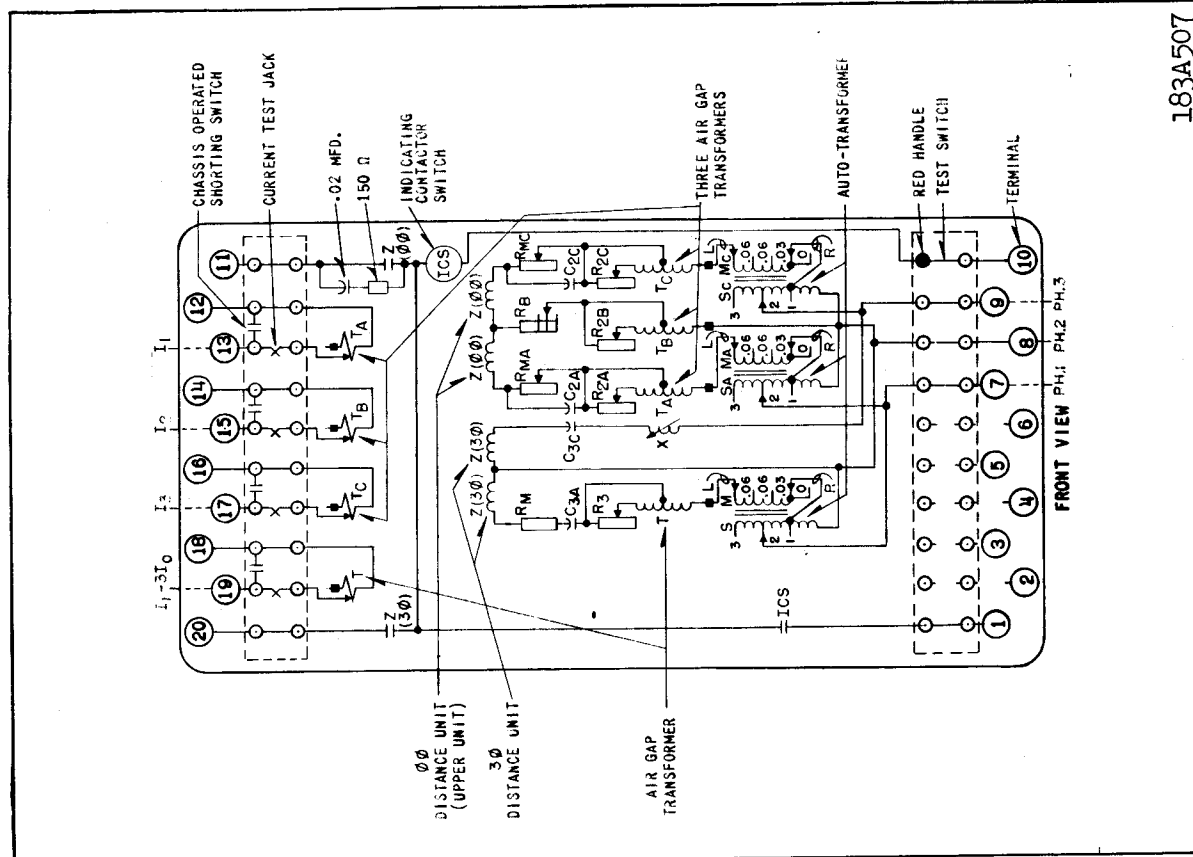

Fig. 4. Internal Schematic of Type KD Relay with 1.0 ampere I.C.S. in the Type FT42 Case. (Relay with 0.2/2.0 ampere I.C.S. unit has identical wiring except that the I.C.S. coil is tapped on terminal 10.)

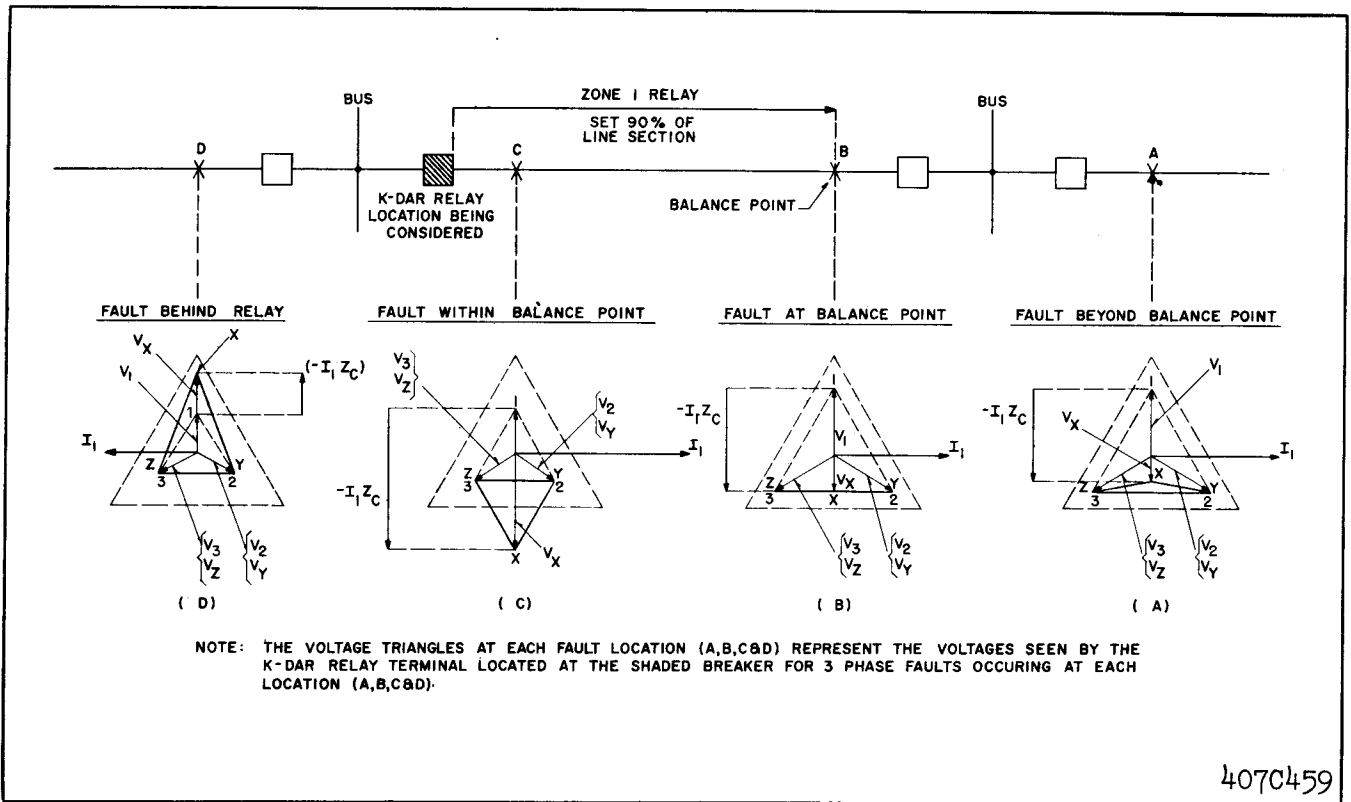

Fig. 6. Voltage and Current Conditions for the Three-Phase Unit at the Shaded Breaker for Three-Phase Faults at Various Locations.

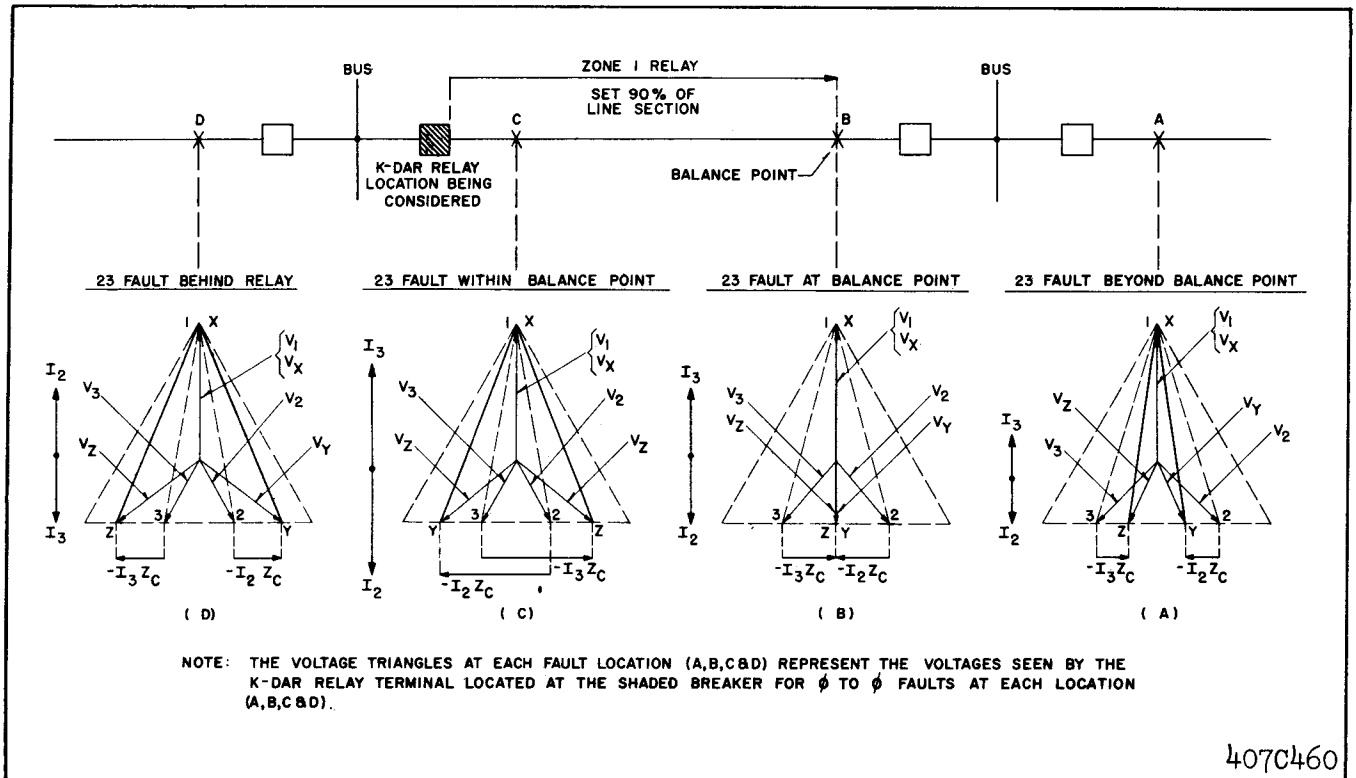

Fig. 7. Voltage and Current Conditions for the Phase-to-Phase Unit at the Shaded Breaker for 23 Faults at Various Locations.

now be considered successively.

Three Phase Unit

A single compensator T has its primary energized with $(I_1 - 3I_0)$ current in Fig. 17. Current I_1 is the phase 1 current; $3I_0$ is the residual current. There are three compensators shown – one for each of the three zones. One connection uses an auxiliary current transformer to insert the $3I_0$ component. The alternate connection supplies the compensator primaries with $(-I_2 - I_3)$. Since $I_1 + I_2 + I_3 = 3I_0$, $(I_1 - 3I_0) = (-I_2 - I_3)$. (Currents I_1 , I_2 and I_3 are the phase currents.) Accordingly, the alternate connection is equivalent to the first arrangement. Note that relay 21-3, a type KD-1, also has a current winding Z. This winding is wound on the tripping unit so that the R-X diagram circle includes the origin, as explained under "Characteristics."

As shown in Fig. 17, the T compensator secondary is connected to modify the phase 1 voltage. With a fault in the trip direction, the induced voltage in the compensator secondary bucks the phase 1 voltage.

Vector diagrams in Fig. 6 illustrate the operation during 3 phase faults at four locations. The system impedance and the compensator angle are assumed to be at 90° for illustrative purposes only. Prefault voltages are depicted by the large triangle. The smaller dashed triangle in each case is the system voltages at the relay location during the fault. This triangle is modified by the compensator voltage, $-I_1 Z_C$, where Z_C is the compensator mutual impedance. The terminals of the tripping unit are designated: X, Y & Z. Phase 1 tripping unit voltage is:

$$V_X = V_1 - I_1 Z_C$$

Phase 2 and phase 3 tripping unit voltages are:

$$V_Y = V_2$$

$$V_Z = V_3$$

For a fault at A, beyond the relay operating zone, the compensator voltage, $-I_1 Z_C$, modifies the phase 1 voltage, reducing the voltage triangle on the tripping unit to X-Y-Z. With an X-Y-Z rotation the tripping unit torque is in the restraining direction.

For a fault at B, the current is larger than for a fault at A, so that $-I_1 Z_C$ is larger. The point X is in line with points Y & Z. No torque is produced, since the X-Y-Z triangle has a zero area.

For a fault in the operating zone, such as at C, point X is below the YZ line. Now the rotation is

X-Z-Y, which produces operating torque.

For a fault behind the relay at D, restraining torque is produced. Since the fault is behind the relay the current is of reversed polarity. Compensator voltage, $-I_1 Z_C$, increases the area of the bus voltage triangle, 1-2-3. Tripping unit voltage has an X-Y-Z rotation which produces restraining torque.

A solid 3 phase fault at the relay location, tends to completely collapse the 1-2-3 voltage triangle. The area of the X-Y-Z triangle also tends to be zero under these conditions. A memory circuit in the KD relay provides momentary operating torque under these conditions, for an internal fault. In the KD-1 relay the coil Z in the current circuit, in conjunction with the compensator voltage, produces a current only torque, which maintains operating torque under the condition of zero potential.

* The R_M and C_{3A} series resistor-capacitor combination in the compensated phase corrects for a shift in the phase-angle relation between the voltage across the left hand coils of Z (3θ) and the voltage across the right hand coils of Z (3θ), in figures 4 and 5. This phase shift is produced by capacitor C_{3C} . The $R_M - C_{3A}$ combination also provides control of transients in the inductive coils of the cylinder unit.

A small variable reactor X is used, in the KD relay only, to compensate for variations in other components and assists the R_M and C_{3A} combination to correct the phase-angle relations. The reactor has two coils which may be connected in the factory either in series or in parallel for stepped adjustment. A screw type core is utilized for changing an internal air gap to produce a continuous adjustment.

Phase-to-Phase Unit

Compensator primaries of T_A , T_B and T_C are energized by I_1 , I_2 and I_3 , respectively, as shown in Fig. 17. Nine compensators are shown, three for each zone. Compensator secondaries are connected to modify their respective phase voltages (e.g. T_A modifies V_1). With a fault in the trip direction, the induced voltages in the compensator secondaries buck the phase voltages.

Vector diagrams in Fig. 7 illustrate the operation during phase 2-3 faults at four locations. The system impedances and the compensator angle are assumed to be at 90° , for illustrative purposes. Prefault voltages are depicted by the large triangles. The smaller dashed triangle in each case is the system voltages at the relay location during the fault. This triangle

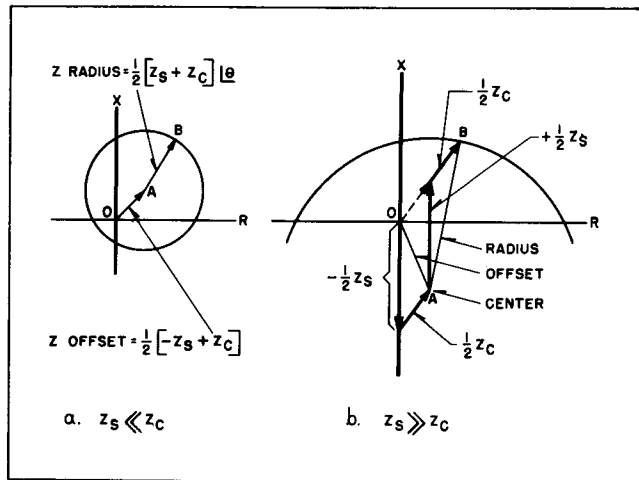

Fig. 8. Impedance Circles for Phase-to-Phase Unit in the Type KD and KD-1 Relay.

is modified by the compensator voltages, $-I_1 Z_C$, $-I_2 Z_C$, and $-I_3 Z_C$, where Z_C is the compensator mutual impedance. In this case $I_1 = 0$, so that only phase 2 and 3 voltages are modified. The terminals of the tripping unit are designated; X, Y and Z. Phase 1 tripping unit voltage is:

$$V_X = V_1 - I_1 Z_C = V_1$$

Phase 2 tripping unit voltage is:

$$V_Y = V_2 - I_2 Z_C$$

Phase 3 tripping unit voltage is:

$$V_Z = V_3 - I_3 Z_C$$

For a fault at A, in Fig. 7, beyond the relay operating zone, the compensator voltages reduce the 1-2-3 triangle to the X-Y-Z triangle. A triangle of this rotation produces restraining torque.

For a fault at B, the compensator voltages are larger, since the current is larger than it is for the fault at A. Points Y & Z coincide and the area of the X-Y-Z triangle is zero. No torque is produced.

For a fault in the operating zone, such as at C, the compensation reverses the rotation to X-Z-Y. Operating torque is produced.

For a fault behind the relay at D, restraining torque is produced. Since the fault is behind the relay, the current is of reversed polarity. Compensator voltages increase the area of the 1-2-3 triangle. Tripping unit voltage has an X-Y-Z rotation. This rotation produces restraining torque.

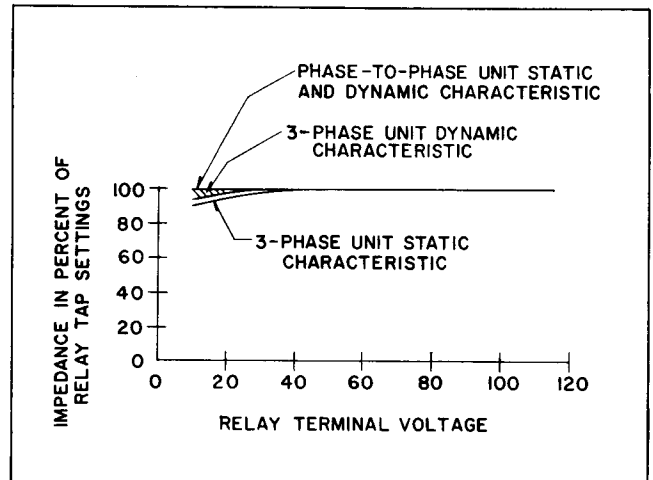

Fig. 9. Impedance Curves for Type KD and KD-1 Relays.

Note that this unit does not require memory action, since the sound-phase voltage reacts with the compensator voltages to produce a strong restraining or a strong operating torque, depending upon the fault location. This is true even for a complete collapse of the faulted phase-to-phase voltage.

Similar vector diagrams apply for a fault between phases 1 & 2 or between phases 3 & 1. The phase-to-phase unit is identical in the KD & KD-1 relays. Each of the three phase-to-phase fault combinations subjects the cylinder unit to a different but similar set of conditions. In order for the phase-to-phase unit to have the same reach for all phase-to-phase faults, particularly at low balance-point voltages, it is necessary that the impedance angles of the three circuits from the relay terminals 7, 8 & 9 to the common connection for Z ($\theta\theta$) and R_B be the same. (See Figs. 4 & 5.) This requirement is fulfilled by the factory adjustment of resistors R_{MA} and R_{MC} . This balance is maintained when S tap 2 or 3 is used by virtue of the balancing resistor R_B in the phase 2 voltage circuit.

CHARACTERISTICS

Distance Characteristic - Phase-To-Phase Unit

This unit responds to all phase-to-phase faults and most two-phase-to-ground faults. It does not respond to load current, (synchronizing surges), or out-of-step conditions. While a characteristic circle can be plotted for this unit on the R-X diagram as shown in Figure 8, such a characteristic circle has no significance except in the first quadrant where resistance and reactance values are positive. A small

portion of the fourth quadrant, involving positive resistance values and negative reactance values, could have some significance in the event that the transmission line includes a series capacitor. The portion of the circle in the first quadrant is of interest because it describes what the relay will do when arc resistance is involved in the fault. The phase-to-phase unit operating on an actual transmission system is inherently directional and no separate directional unit is required.

An inspection of Figure 8 indicates that the circle of the phase-to-phase unit is dependent on source impedance Z_S . However, the circle *always* goes through the line balance point impedance. The reach at the compensator (and line) angle is constant, regardless of the system source impedance. The broadening out of the characteristic circle with a relatively high source impedance gives the phase-to-phase unit the advantageous characteristic that for short lines, it makes a greater allowance for resistance in the fault. Stated another way, the characteristics approach that of a reactance relay more and more closely as the line being protected becomes shorter and shorter with respect to the source impedance back of the relaying location.

Sensitivity: Phase-to-Phase Unit

A plot of relay reach, in percent of tap block setting, versus relay terminal voltage is shown in Figure 9. The unit will operate with the correct directional sense for zero voltage phase-to-phase faults. For this condition the fault current must be not less than 0.015 relay amperes with an ohm setting of 5.8 with rated voltage on the unfaulted phase. Pick up current is

proportionately higher in $S = 2$ and $S = 3$ taps.

The KD relay may be set without regard to possible overreach due to d-c transients. Compensators basically are insensitive to d-c transients which attend faults on high-angle systems. The long time-constant of a high-angle system provides a minimum rate of change in flux-producing transient current with respect to time, and therefore induces a minimum of uni-directional voltage in the secondary. Asymmetrical currents resulting from faults on low-angle systems having a short time constant can induce considerable voltage in the secondary, but for the first half cycle, the transient-derived voltage subtracts from the steady-state value. This transient decays so rapidly that it is insignificant during the second half cycle when it adds to the steady-state value.

Distance Characteristic - KD, 3 Phase Unit

The three-phase unit has a characteristic circle which passes through the origin as shown in Figure 10. This circle is independent of source impedance. The three-phase unit is also inherently directional and does not require a separate directional unit.

If a solid-three phase fault occurs right at the relay location, the entire voltage triangle collapses to zero to give a balance point condition, as shown by the relay characteristic (in Figure 10) which passes through the origin. However, since the YZ voltage also drops to zero, the relay would be unable to determine whether an internal or external fault existed. To correct this condition, a resonant circuit is added to the 23 voltage circuit of the relay which allows the YZ voltage to collapse gradually, thus

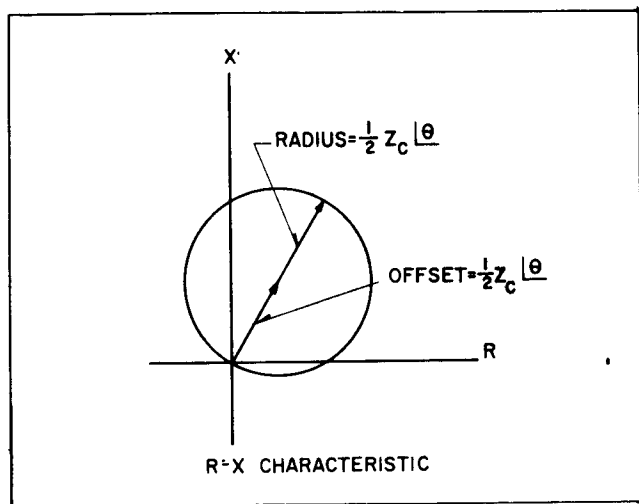

Fig. 10. Impedance Circle for Three-Phase Unit in Type KD Relay.

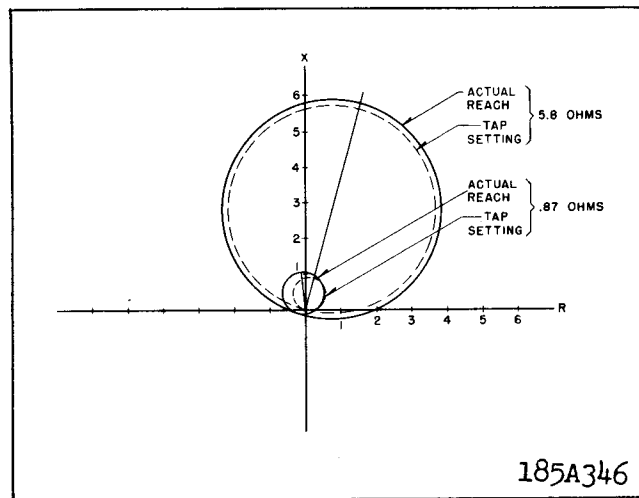

Fig. 11. Impedance Circle for Three-Phase Unit in Type KD-1 Relay.

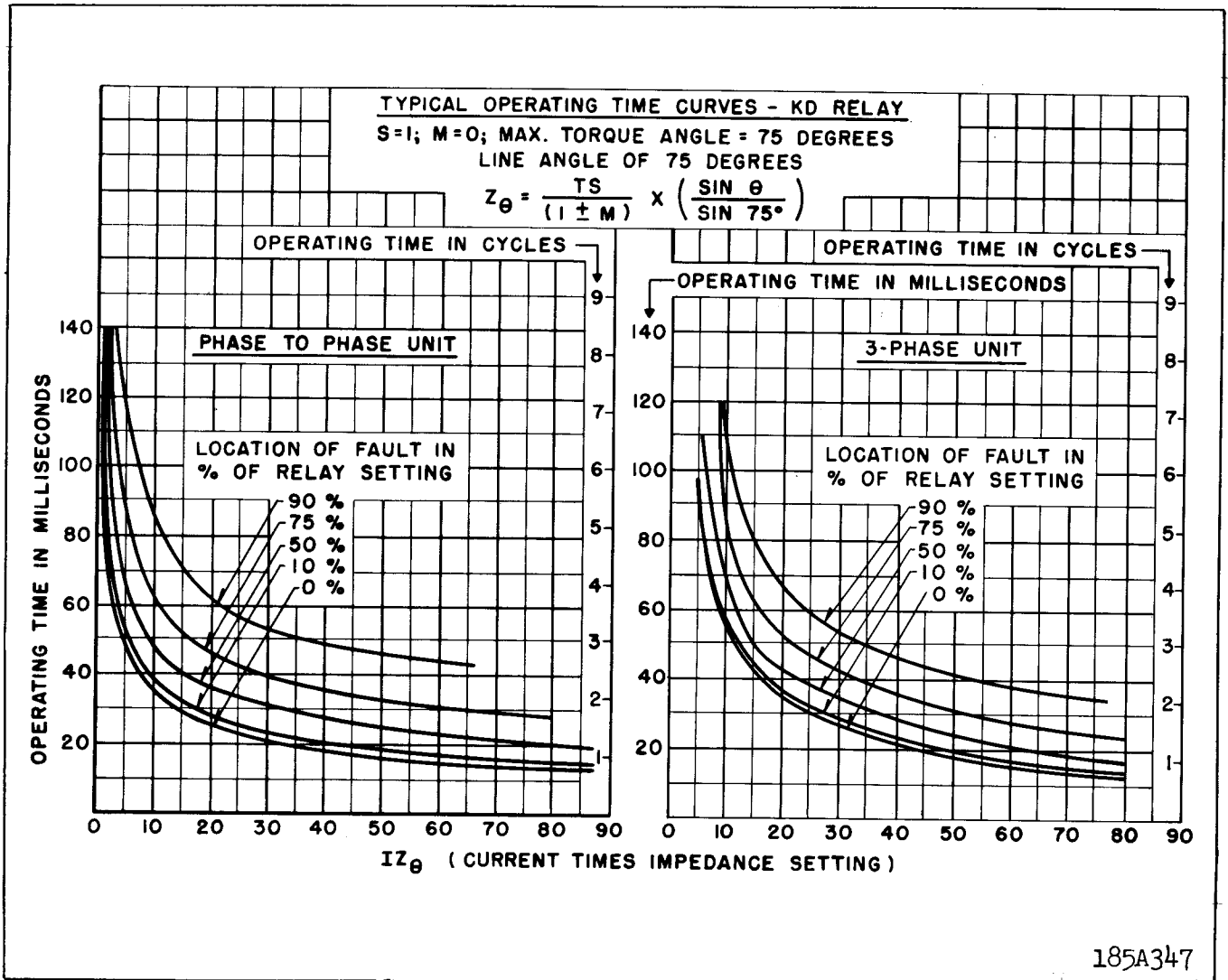

Fig. 12. Typical Operating Time Curves of Type KD Relay. Normal voltage before the fault is 120 volts.

giving a reference voltage to determine whether the fault is inside the protected line section or behind the relay.

Sensitivity - KD, 3 Phase Unit

The impedance curve for the KD three-phase unit is shown in Figure 9.

The unit will operate with the correct directional sense for zero voltage three-phase faults when normal voltage exists at the relay terminals prior to the fault. This operation occurs due to memory action as described above. The unit will have zero torque or perhaps a slight opening torque if there is zero voltage at the relay prior to the fault or after the memory action has subsided. With an impedance setting of

5.8 ohms the three-phase unit will directionally operate for faults which produce 2 volts line to line and 1.0 ampere at the relay terminals.

Sensitivity with 2 volts line-to-line for any tap is defined by the following equation:

$$I = \frac{5.8}{T} \text{ amperes}$$

The KD relay may be set without regard to possible overreach due to d-c transients.

Distance Characteristic: KD-1 3 Phase Unit

The three-phase unit of the KD-1 relay has a characteristic circle which includes the origin as

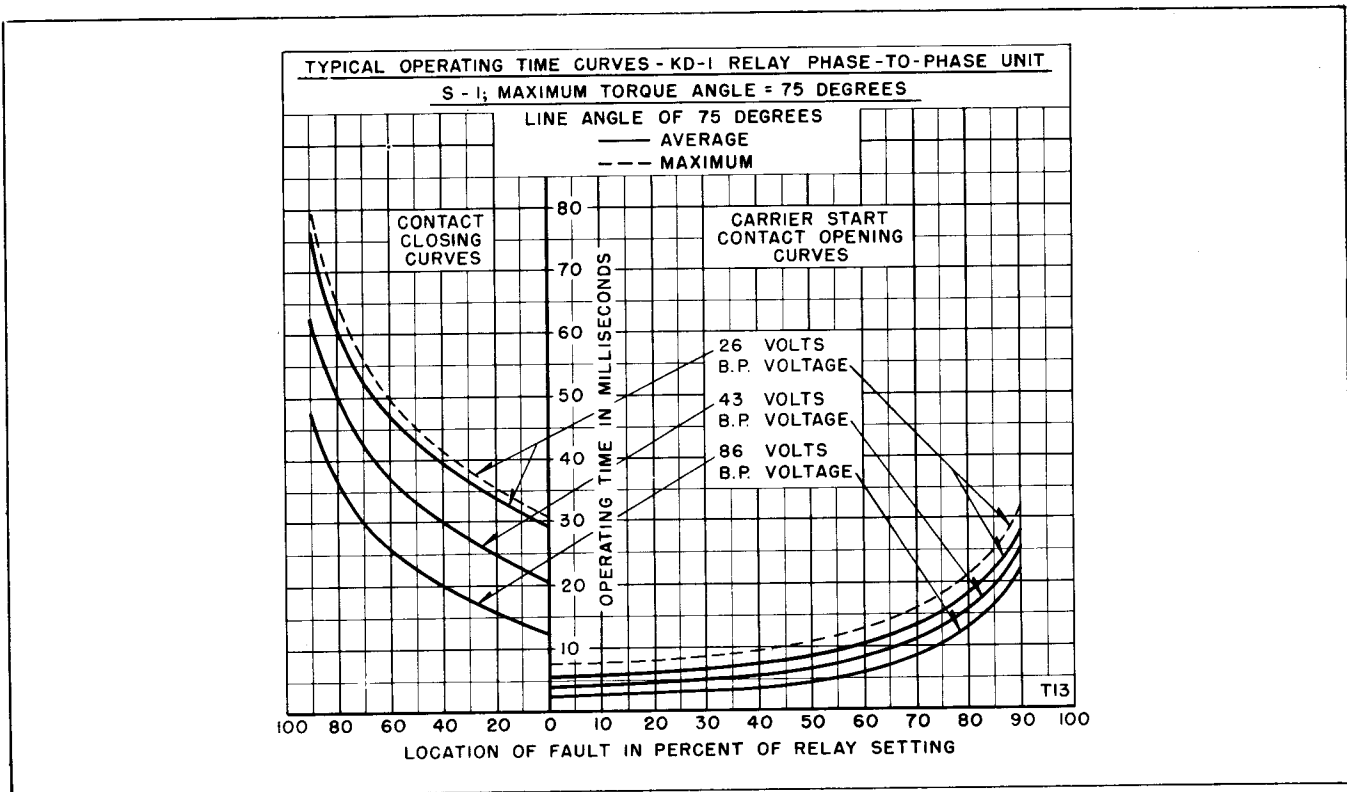

Fig. 13. Typical Operating Time Curves of Type KD-1 Relay Phase-to-Phase Unit. Normal voltage before the fault is 120 volts.

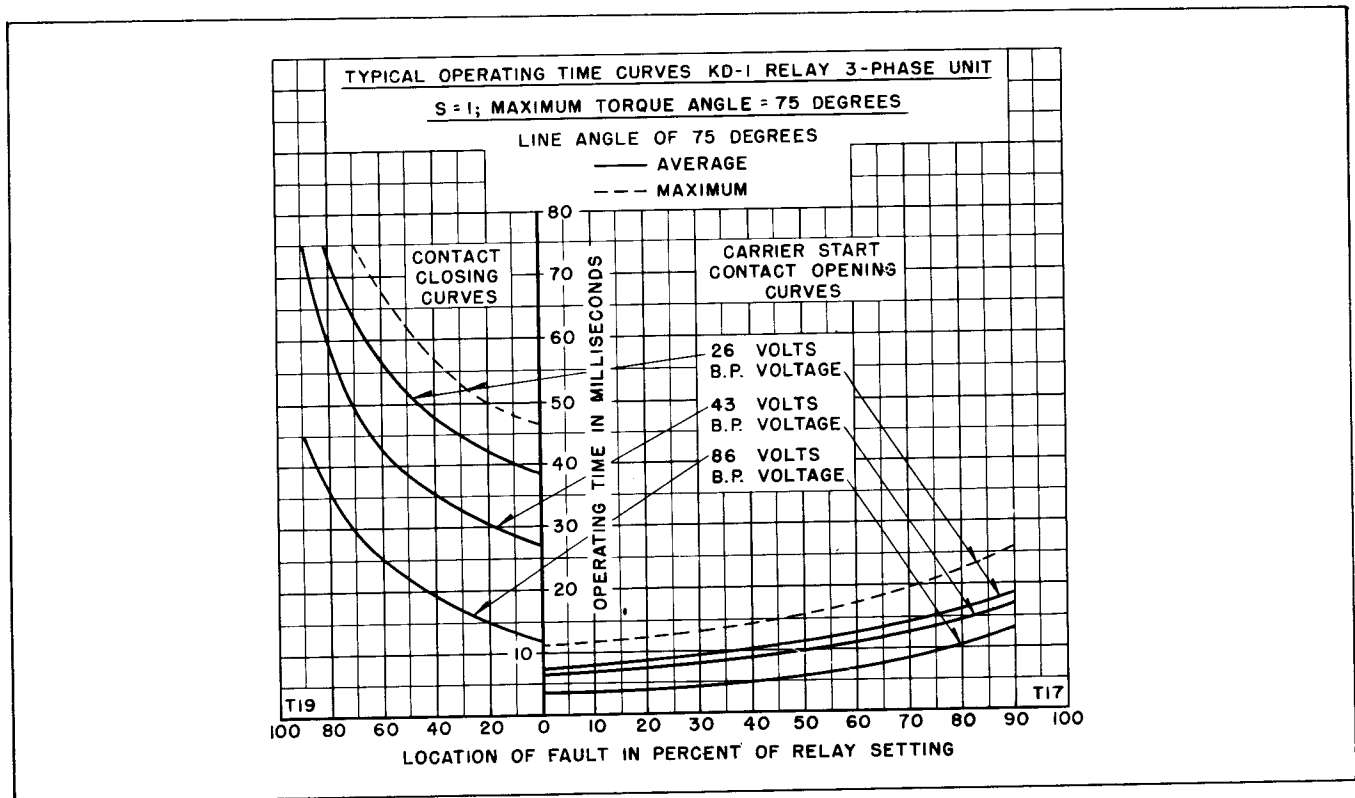

Fig. 14. Typical Operating Time Curves of Type KD-1 Relay Three-Phase Unit. Normal voltage before the fault is 120 volts.

shown in Figure 11. The reverse reach of this unit varies from 0.11 ohms for a T setting of .87 to 0.13 ohms for a T setting of 5.8. The forward reach of the unit varies from 102 percent of tap value for a T setting of 5.8 and 75 degrees to 120 percent of tap value at 95 degrees for a T setting of .87. Figure 11 compares the KD and KD-1 reach for identical settings. The KD circles are dashed. The maximum torque angle is set for 75 degrees while T is set at 5.8.

A single turn current coil on the cylinder unit provides for current-only torque and is small compared to the many turns of the 5.8 setting of the compensator and has very little influence on the overall settings. However, as the compensator setting is reduced, the single turn current coil becomes larger by comparison and has more and more effect on the overall settings.

Sensitivity: KD-1 3 Phase Unit

The impedance curve for the KD-1 three-phase unit is shown in Figure 9. This unit will operate to close the left hand contact on current only for 3 or more amperes relay current with T set for 5.8 and for 7.5 amperes or more with T set for .87.

General Characteristics

Impedance settings in ohms reach can be made for any value from .75 ohms to 20 ohms in steps of 3 percent. The maximum torque angle, which is set for 75 degrees at the factory, may be set for any value from 60 degrees to 80 degrees. A change in maximum torque angle will produce a slight change in reach for any given setting of the relay. Referring to Fig. 2 note that the compensator secondary voltage output V, is largest when V leads the primary current, I, by 90°. This 90° relationship is approached, if the compensator loading resistor (R₃, R_{2A}, R_{2B} or R_{2C}) is open-circuited. The effect of the loading resistor, when connected, is to produce an internal drop in the compensator, which is out-of-phase with the induced voltage, IT, IT_A, IT_B or IT_C: Thus the net voltage, V, is phase-shifted to change the compensator maximum torque angle. As a result of this phase shift the magnitude of V is reduced, as shown in Fig. 2.

Tap markings in Fig. 3 are based upon a 75° compensator angle setting. If the resistors R₃, R_{2A}, R_{2B} and R_{2C} are adjusted for some other maximum torque angle the nominal reach is different than indicated by the taps. The reach, Z_θ, varies with the maximum

torque angle, θ, as follows:

$$Z_{\theta} = \frac{TS \sin \theta}{(1 \pm M) \sin 75^{\circ}}$$

TAP PLATE MARKINGS

(T, TA, TB, and TC)						
.87	1.16	1.6	2.2	3.0	4.2	5.8
(S, SA, SC, RB)						
1	2	3				
(M, MA, MC)						
± Values between taps .03 .06 .06						

TIME CURVES AND BURDEN DATA

Operating Time

The speed of operation for the KD relay three-phase and phase-to-phase units is shown by the time curves in Figure 12. The curves indicate the time in milliseconds required for the relay to close its contacts for tripping after the inception of a fault at any point on a line within the relay setting.

Figure 13 and Figure 14 show the KD-1 operating time of the phase-to-phase unit and the three-phase unit respectively. These curves show both contact-opening time and contact-closing time for faults within the relay setting.

Current Circuit Rating in Amperes

Tap Setting	Continuous			1 Second
	S=1	S=2	S=3	
5.8	5.0	8.5	9.5	240
4.2	6.0	10.	10.	240
3.0	8.0	10.	10.	240
2.2	10.	10.	10.	240
1.6	10.	10.	10.	240
1.16	10.	10.	10.	240
0.87	10.	10.	10.	240

Burden

The burden which the relays impose upon potential and current transformers in each phase is shown by Figure 15 and Figure 16 for the KD and KD-1 relays respectively. The potential burden and burden phase angle are based on 69 volts line-to-neutral applied to the relay terminals.

Trip Circuit Constants

1 ampere rating:	0.1 ohms d.c. resistance
0.2/2.0 ampere rating:	0.2 tap — 6.5 ohms
	2 tap — 0.15 ohms

TYPES KD AND KD-1 RELAYS

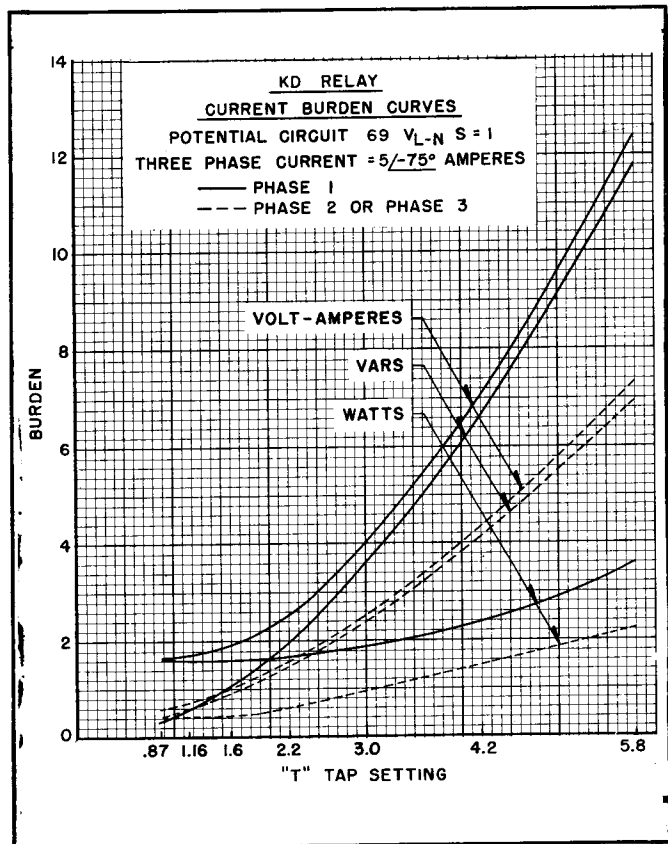
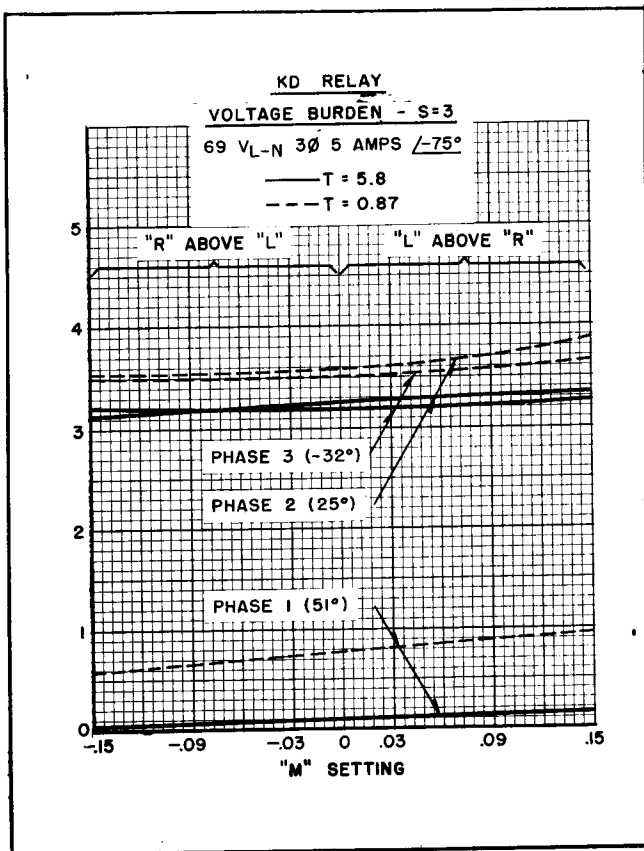
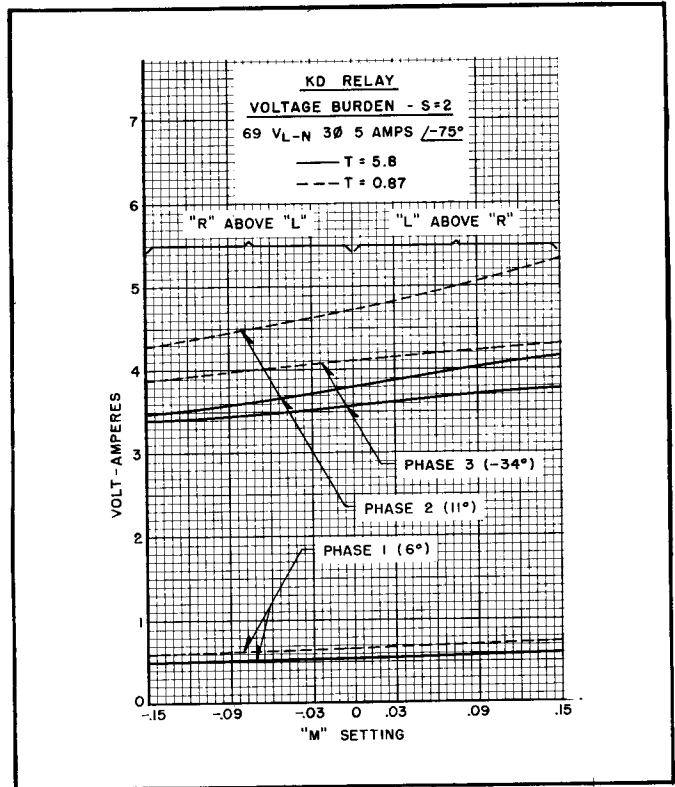
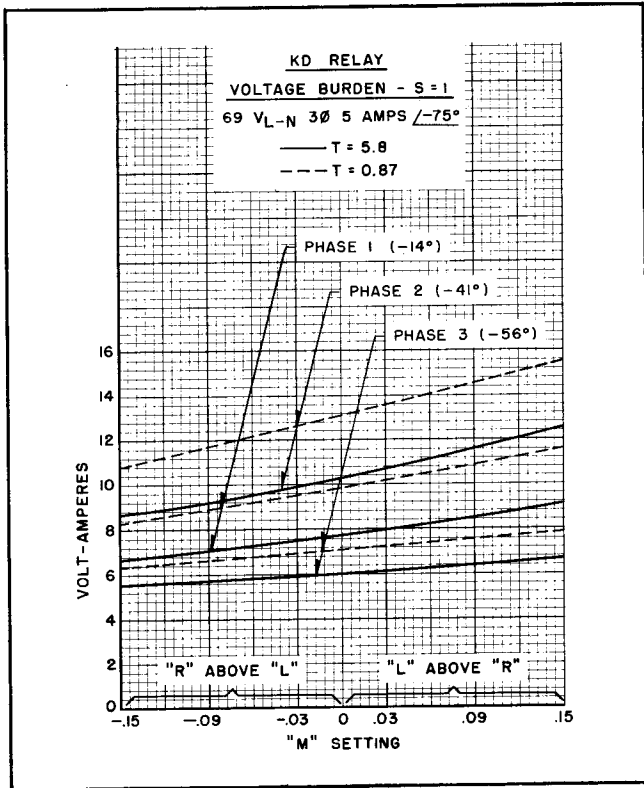

Fig. 15. Type KD Relay Burden Data.

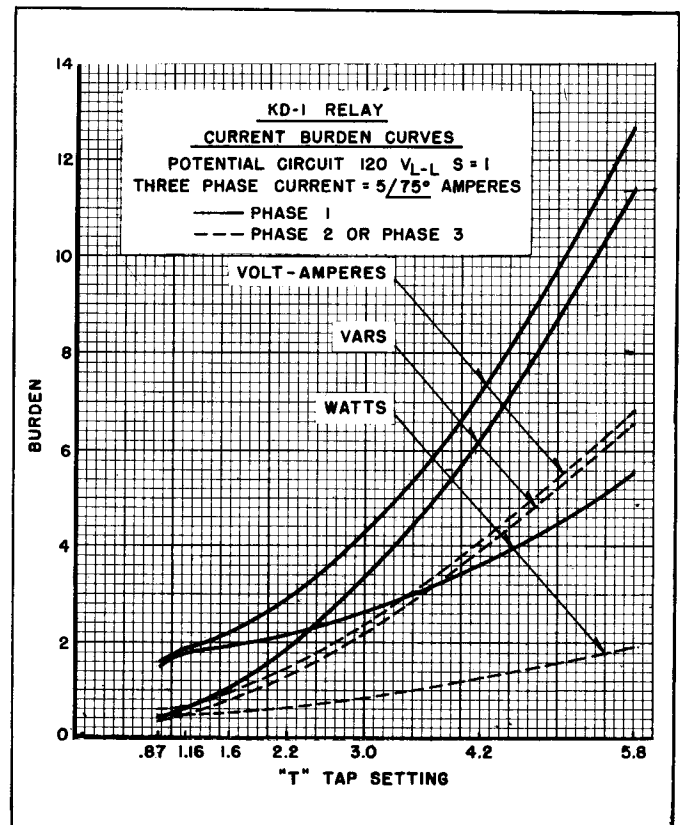
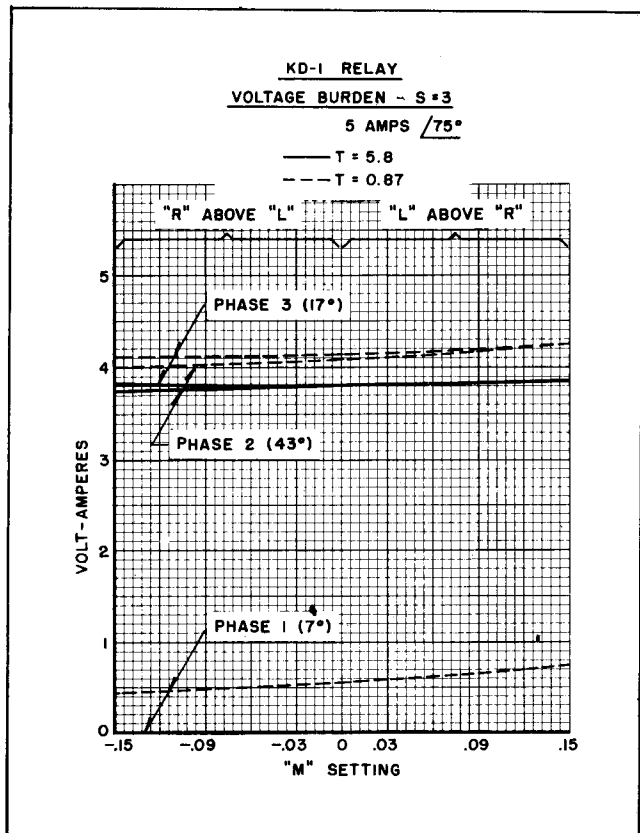
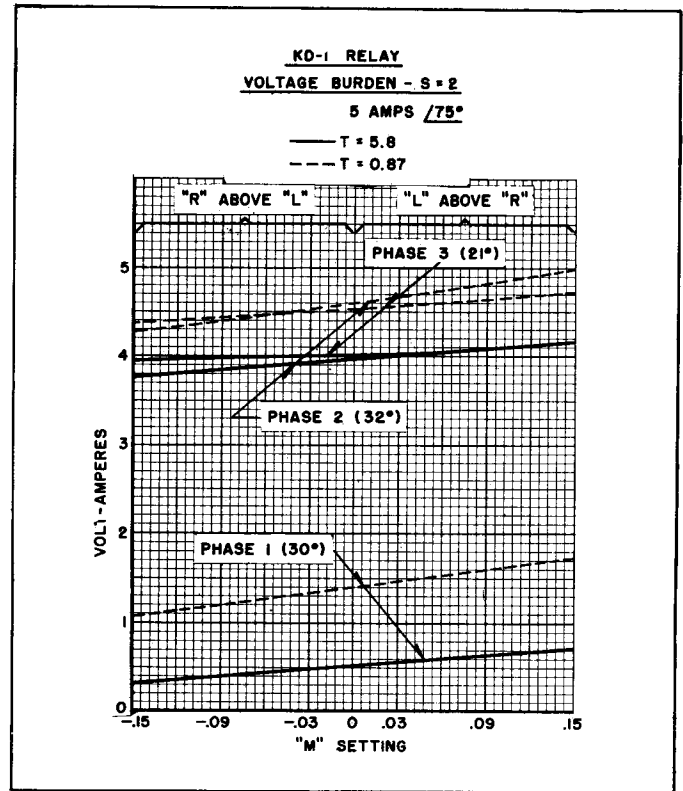
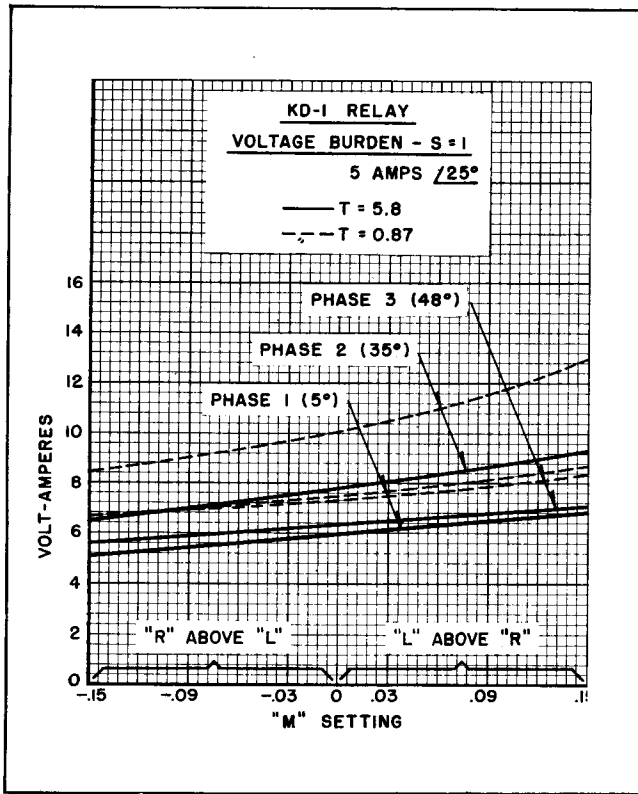

Fig. 16. Type KD-1 Relay Burden Data.

SETTING CALCULATIONS

Relay reach is set on the tap plate shown in Fig. 3. The tap markings are:

T, T _A , T _B and T _C				
.87	1.16	1.6	2.2	3.0 4.2 5.8

S, S _A , R _B and S _C		
1	2	3

M, M _A , M _C		
.03	.06	.06

(Values between taps)

Maximum torque angle is set for 75° (current lagging voltage) in the factory. This adjustment need not be disturbed for line angles of 65° or higher. For line angles below 65°, set for a 60° maximum torque angle, by adjusting R₃, R_{2A}, R_{2B} and R_{2C}. Set zone 1 reach to be 90% of the line (85% for line angles of less than 50°).

Calculations for setting the KD and KD-1 relays are straightforward and apply familiar principles. Assume a desired balance point which is 90 percent of the total length of line. The general formula for setting the ohms reach of the relays is:

$$Z_{\theta} = Z \frac{(\sin \theta)}{(\sin 75^{\circ})} = Z_{pri} \frac{0.9 R_c}{R_v}$$

The terms used in this formula are defined as follows:

- Z_θ = the desired ohmic reach of the relay in secondary ohms.
- Z = $\frac{TS}{1 \pm M}$ = the tap plate setting.
- T = compensator tap value
- S = Auto-transformer primary tap value
- θ = Maximum torque angle setting of the relay.

(For a factory setting of 75° then $\frac{\sin \theta}{\sin 75^{\circ}} = 1$.)

M = Auto-transformer secondary tap value.
(This is a Per Unit value and is determined by the sum of the values between the "L" and the "R" leads. The sign is positive when "L" is above "R" and acts to Lower the Z setting. The sign is negative when "R" is above "L" and acts to raise the Z setting).

Z_{pri} = ohms per phase of the total line section

0.9 = the portion of the total line for which the relay is set.

R_c = current transformer ratio

R_v = potential transformer ratio

The following procedure should be followed in order to obtain an optimum setting of the relay.

1. Select the lowest tap S which gives a product of 6.9 S greater than Z where $Z = Z_{\theta} \frac{(\sin 75^{\circ})}{(\sin \theta)}$.
2. Select a value for T that is nearest the value $\frac{Z}{S}$.
3. Determine the value of M that will most nearly make $M = \frac{TS}{Z} - 1$. If the sign is negative, then the M taps are connected with the R lead above the L lead to Raise the setting.

For example, assume the desired reach, Z_θ of the relay is 7 ohms at 60 degrees. Then Z = 7 x 1.11 = 7.8 ohms.

1. The lowest tap S for 6.9 S greater than 7.8 is S = 2
Set S, S_A, R_B, and S_C in tap 2.
2. T nearest to $\frac{7.8}{2} = 3.9$ is 4.2 ohms
Set T, T_A, T_B and T_C in tap 4.2.
3. $M = \frac{8.4}{7.8} - 1 = 1.075 - 1 = .075$ (Use M = .09)
Set M, M_A and M_C for + .09.
4. Then $Z = \left(\frac{4.2 \times 2}{1 + .09} \right) = 7.7$ ohms
5. $Z_{\theta} = Z \left(\frac{\sin \theta}{\sin 75^{\circ}} \right) = 6.9$ relay ohms at a maximum torque angle setting of 60 degrees which is 98.6% of the desired value.
6. Set R₃, R_{2A}, R_{2B} and R_{2C} for 60° maximum torque angle.

SETTING THE RELAY

The KD and KD-1 relays require settings for each of the four compensators (T, T_A, T_B, and T_C), each of the three auto-transformers, primaries (S, S_A, and

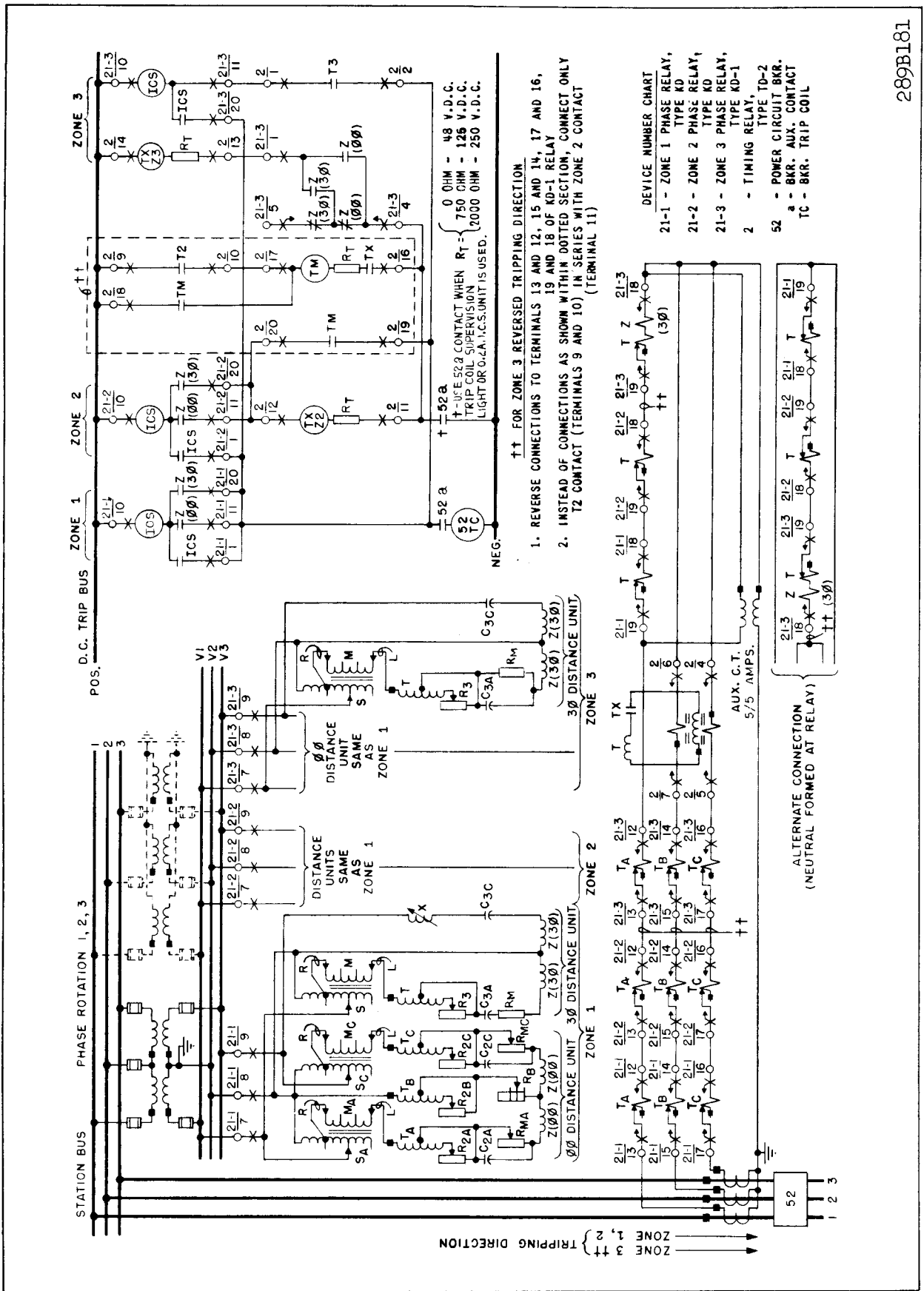

289B181

* Fig. 17. External Schematic of Two Type KD and one KD-1 Relays with Type TD-2 Timing Relay.

S_C) and secondaries (M , M_A , and M_C), and the balancing resistor R_B which should be set at the same value as S_A and S_C . All of these settings are made with taps on the tap plate which is located between the operating units. Fig. 3 shows the tap plate.

Compensator (T , T_A , T_B , and T_C)

Each set of compensator taps terminate in inserts which are grouped on a socket and form approximately three quarters of a circle around a center insert which is the common connection for all of the taps. Electrical connections between common insert and tap inserts are made with a link that is held in place with two connector screws, one in the common and one in the tap.

A compensator tap setting is made by loosening the connector screw in the center. Remove the connector screw in the tap end of the link, swing the link around until it is in position over the insert for the desired tap setting, replace the connector screw to bind the link to this insert, and retighten the connector screw in the center. Since the link and connector screws carry operating current, be sure that the screws are turned to bind snugly.

Auto-Transformer Primary (S , S_A , and S_C)

Primary tap connections are made through a single lead for each transformer. The lead comes out of the tap plate through a small hole located just below the taps and is held in place on the proper tap by a connector screw, (Figure 3).

An "S" setting is made by removing the connector screw, placing the connector in position over the insert of the desired setting, replacing and tightening the connector screw. The connector should never make electrical contact with more than one tap at a time.

Auto-Transformer Secondary (M , M_A , and M_C)

Secondary tap connections are made through two leads identified as L and R for each transformer. These leads come out of the tap plate each through a small hole, one on each side of the vertical row of "M" tap inserts. The lead connectors are held in place on the proper tap by connector screws.

Values for which an "M" setting can be made are from $-.15$ to $+.15$ in steps of $.03$. The value of a setting is the sum of the numbers that are crossed when going from the R lead position to the L lead position. The sign of the "M" value is determined by which lead is in the higher position on the tap plate. The

sign is positive (+) if the L lead is higher and negative (-) if the R lead is higher.

An "M" setting may be made in the following manner. Remove the connector screws so that the L and R leads are free. Determine from the following table the desired "M" value. Neither lead connector should make electrical contact with more than one tap at a time.

Tabulated Settings			
<u>Z₇₅₀</u>	<u>M</u>	<u>L Lead</u>	<u>R Lead</u>
0.87 TS	+ .15	Upper .06	0
0.89 TS	+ .12	Upper .06	.03
0.92 TS	+ .09	Lower .06	0
0.94 TS	+ .06	Upper .06	Lower .06
0.97 TS	+ .03	.03	0
TS	0	0	0
1.03 TS	- .03	0	.03
1.06 TS	- .06	Lower .06	Upper .06
1.1 TS	- .09	0	Lower .06
1.14 TS	- .12	.03	Upper .06
1.18 TS	- .15	0	Upper .06

R_B Settings

R_B is a circuit balancing resistor for the phase-to-phase unit. The R_B tap setting should be the same as S_A and S_C settings.

Line Angle Adjustment

Maximum torque angle is set for 75° (current lagging voltage) in the factory. This adjustment need not be disturbed for line angles of 65° or higher. For line angles below 65° , set for a 60° maximum torque angle by adjusting the compensator loading resistors R_3 , R_{2A} , R_{2B} and R_{2C} . Refer to repair calibration parts I (C) and II (B), when a change in maximum torque angle is desired.

Indicating Contactor Switch (ICS)

No setting is required for relays with a 1.0 ampere unit. For relays with a 0.2/2.0 ampere unit, connect the lead located in front of the tap block to the desired setting by means of the connecting screw. When the relay energizes a 125- or 250-volt d-c type WL relay switch, or equivalent, use the 0.2 ampere tap; for 48-volt d-c applications set the unit in a tap 2 and use a Type WL relay with a S#304C209G01 coil, or equivalent.

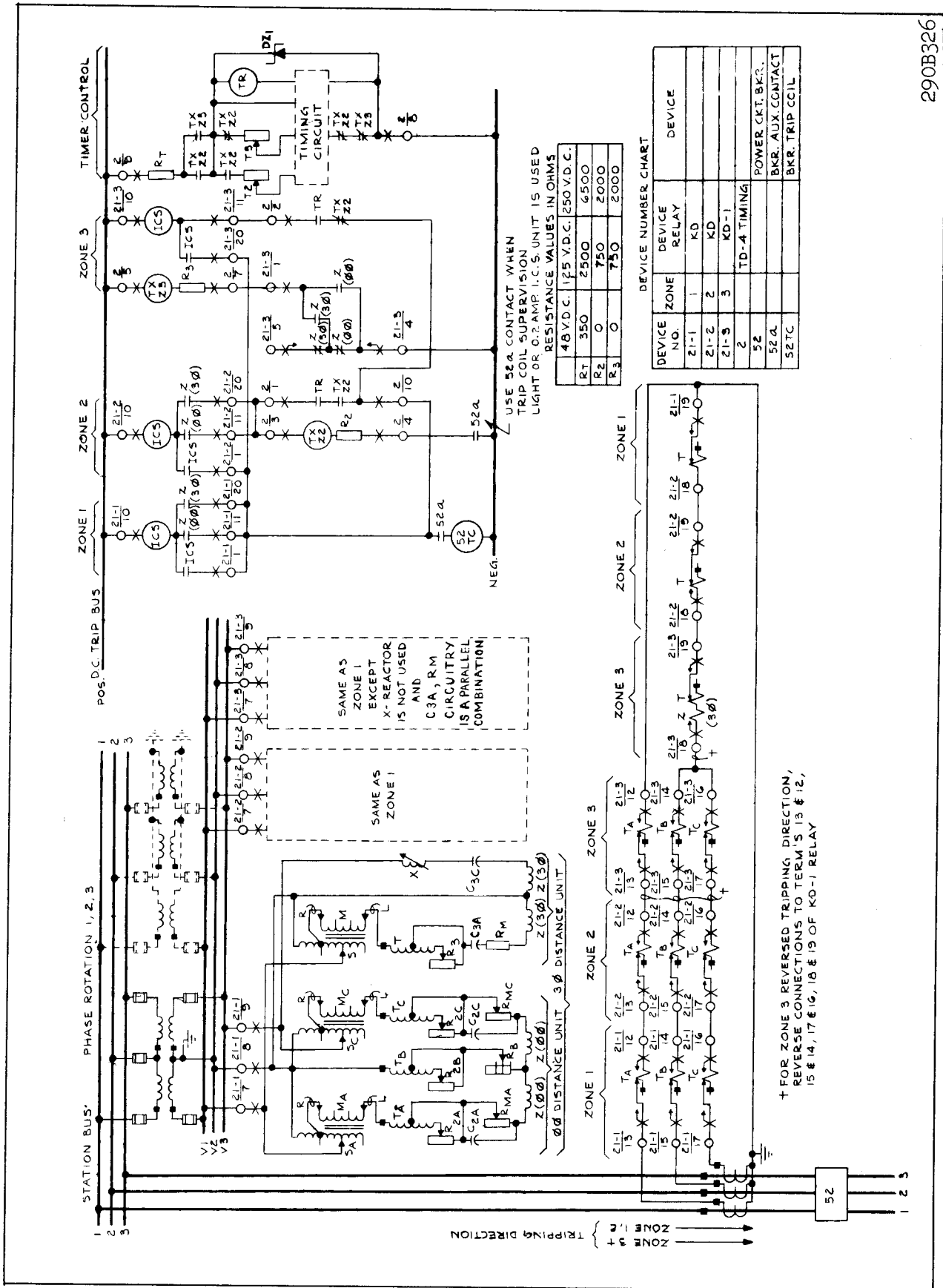

290B326

* Fig. 18 External Schematic of Two Type KD and One KD-1 Relay with Type TD-4 Timing Relay.

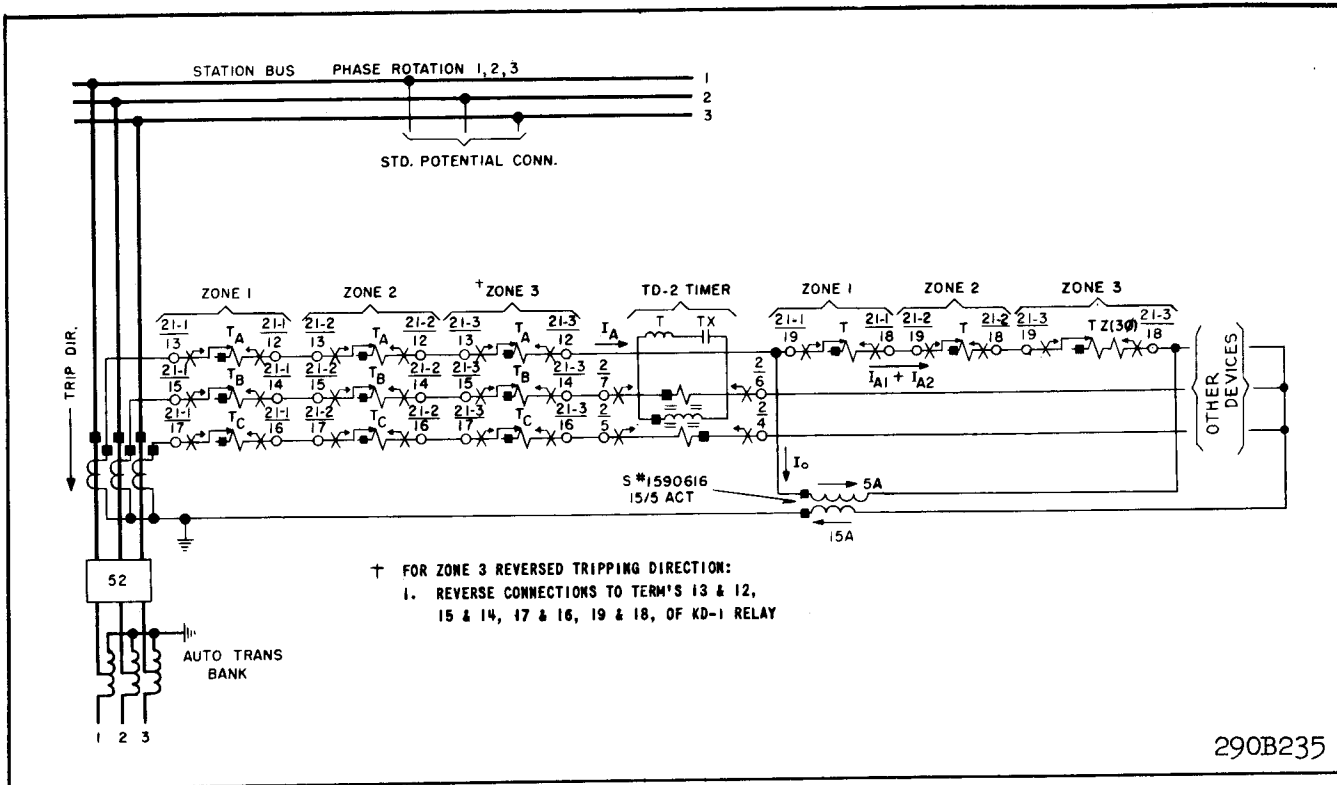

290B235

Fig. 19 A.C. External Schematic of Two Type KD & One KD-1 Relay with Type TD-2 Timing Relay - Autotransformer Termination.

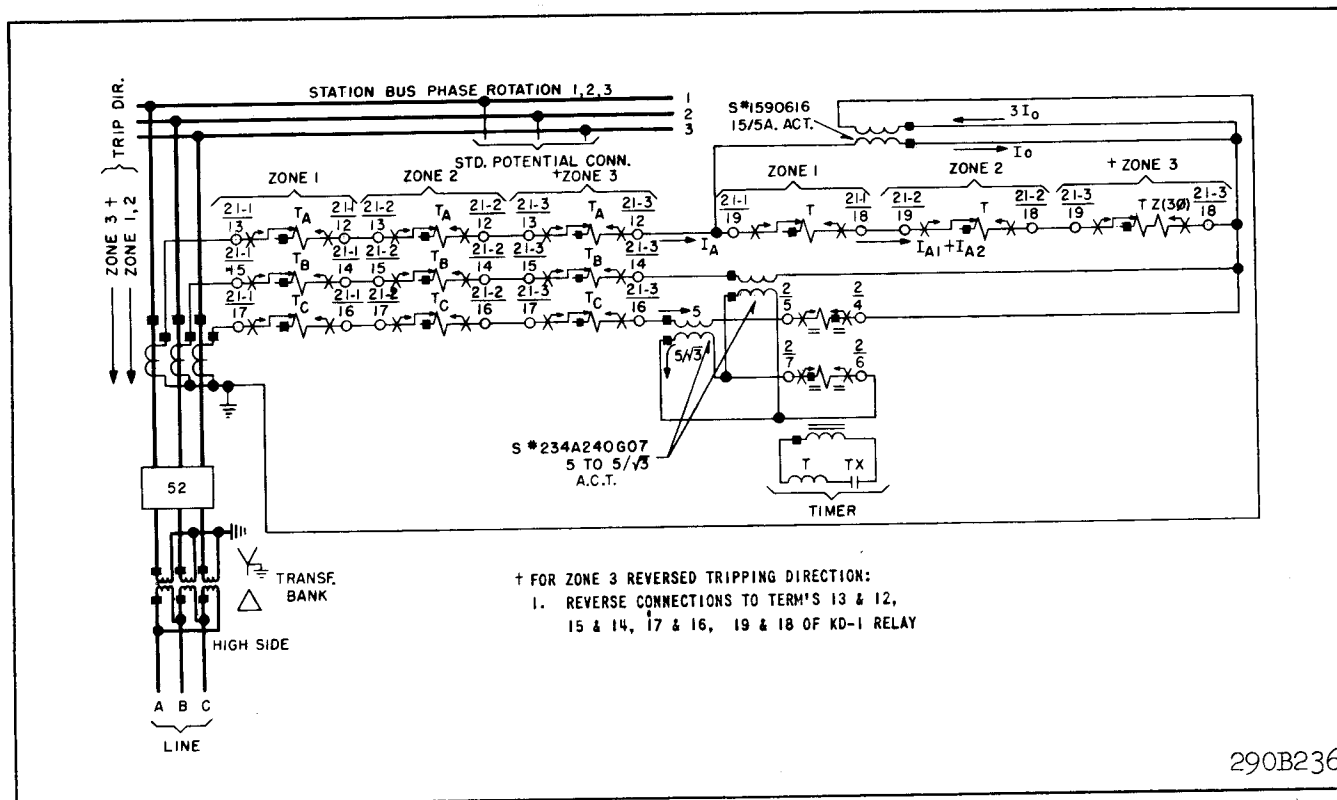

290B236

Fig. 20 A.C. External Schematic of Two Type KD & One KD-1 Relay with Type TD-2 Timing Relay - Wye-Delta Bank Termination with Grounded Wye on Relay Side.

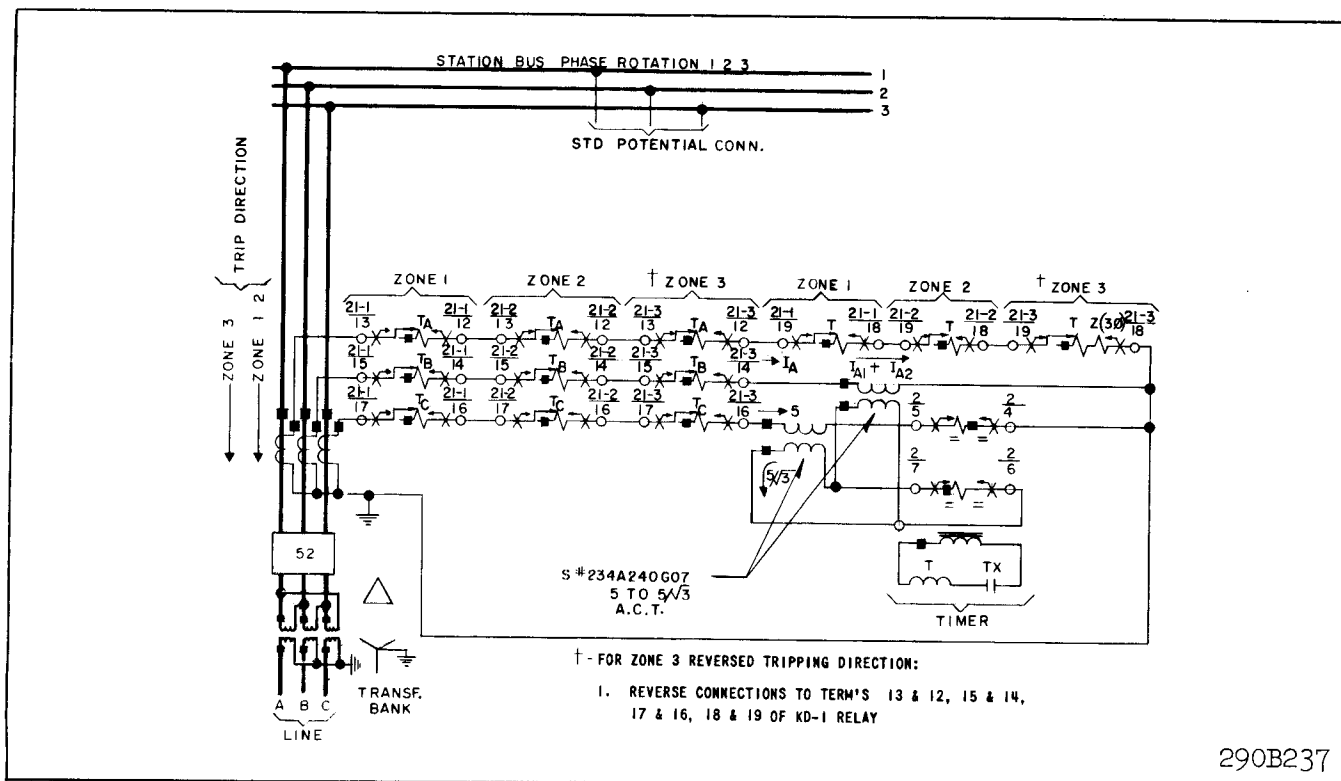

Fig. 21 A.C. External Schematic of Two Type KD & One KD-1 Relay with Type TD-2 Timing Relay - Wye-Delta Bank Termination with Delta on Relay Side.

INSTALLATION

The relays should be mounted on switchboard panels or their equivalent in a location free from dirt, moisture, excessive vibration and heat. Mount the relay vertically by means of the mounting stud for the type FT projection case or by means of the four mounting holes on the flange for the semi-flush type FT case. Either the stud or the mounting screws may be utilized for grounding the relay. The electrical connections may be made directly to the terminals by means of screws for steel panel mounting or to the terminal stud furnished with the relay for thick panel mounting. The terminal stud may be easily removed or inserted by locking two nuts on the stud and then turning the proper nut with a wrench.

For detail information on the FT case refer to IL 41-076.

EXTERNAL CONNECTIONS

Fig. 17 shows the connections for 3 zone protection utilizing the TD-2 timer. Fig. 18 is similar to

Fig. 17 except that the TD-4 timer is used instead of the TD-2. Fig. 18 does not show the use of the 5/5 auxiliary current transformer so that the CT neutral may be formed elsewhere; however, this connection is equally applicable whether the TD-2 or TD-4 timer is employed.

A-C connections for additional applications are shown in Figs. 19, 20, 21, 22 and 23. Three of these, Figs. 19, 20 and 21 apply when the transmission line is terminated in a power transformer, and when low side voltage and current are used to energize the relays. In calculating the reach settings, the bank impedance must be added to the line impedance.

For the case of a wye-delta bank (Figs. 20 and 21) the voltages and currents are phase-shifted by 30°; however, this fact should be ignored, as the KD and KD-1 relays are not affected by this phase shift.

Use the connections of Fig. 22 when the Z_{θ} is less than 0.75 ohms. The 2 to 1 or 3 to 1 auxiliary current transformers reduce the relay current. In ef-

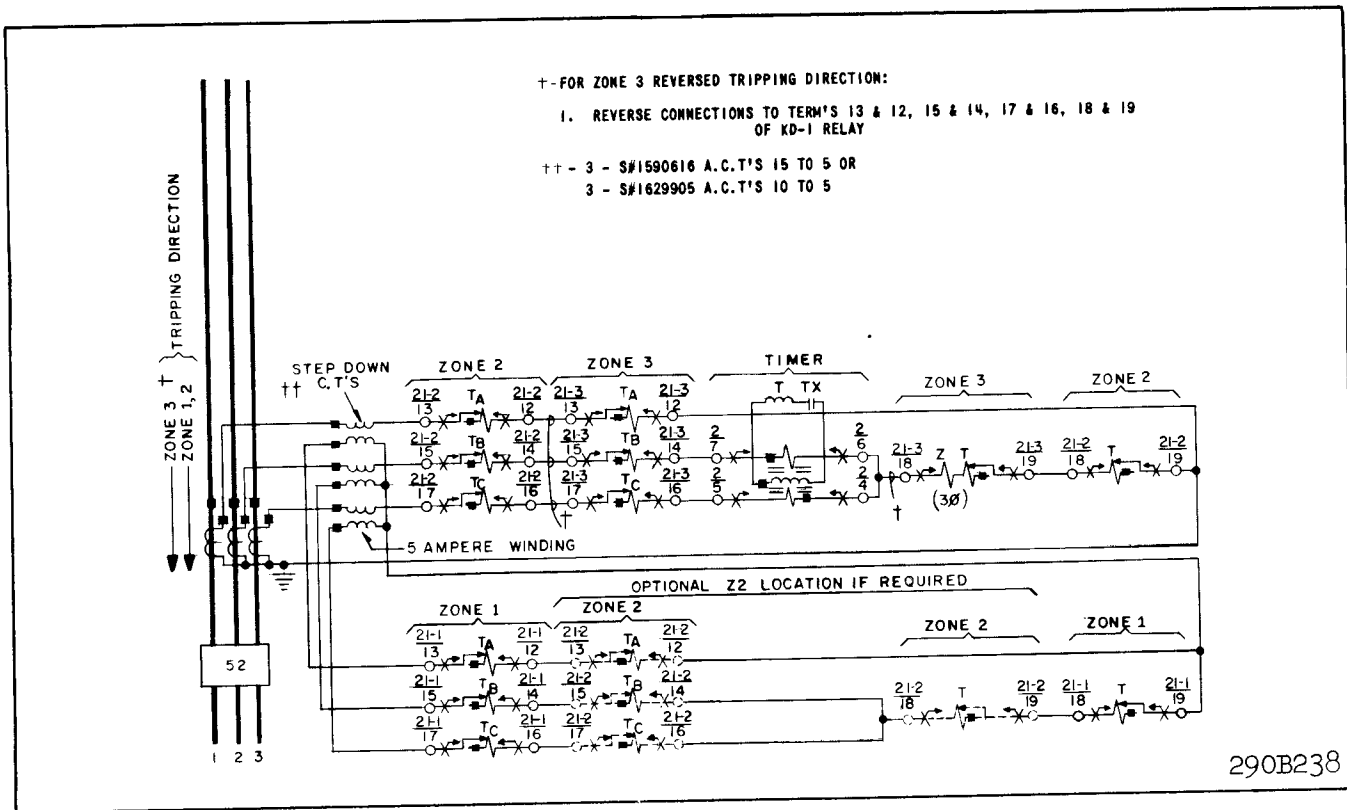

Fig. 22 A.C. External Schematic of Two Type KD & One KD-1 Relay with Type TD-2 Timing Relay - for Ohmic Settings Below 0.75 Ohms.

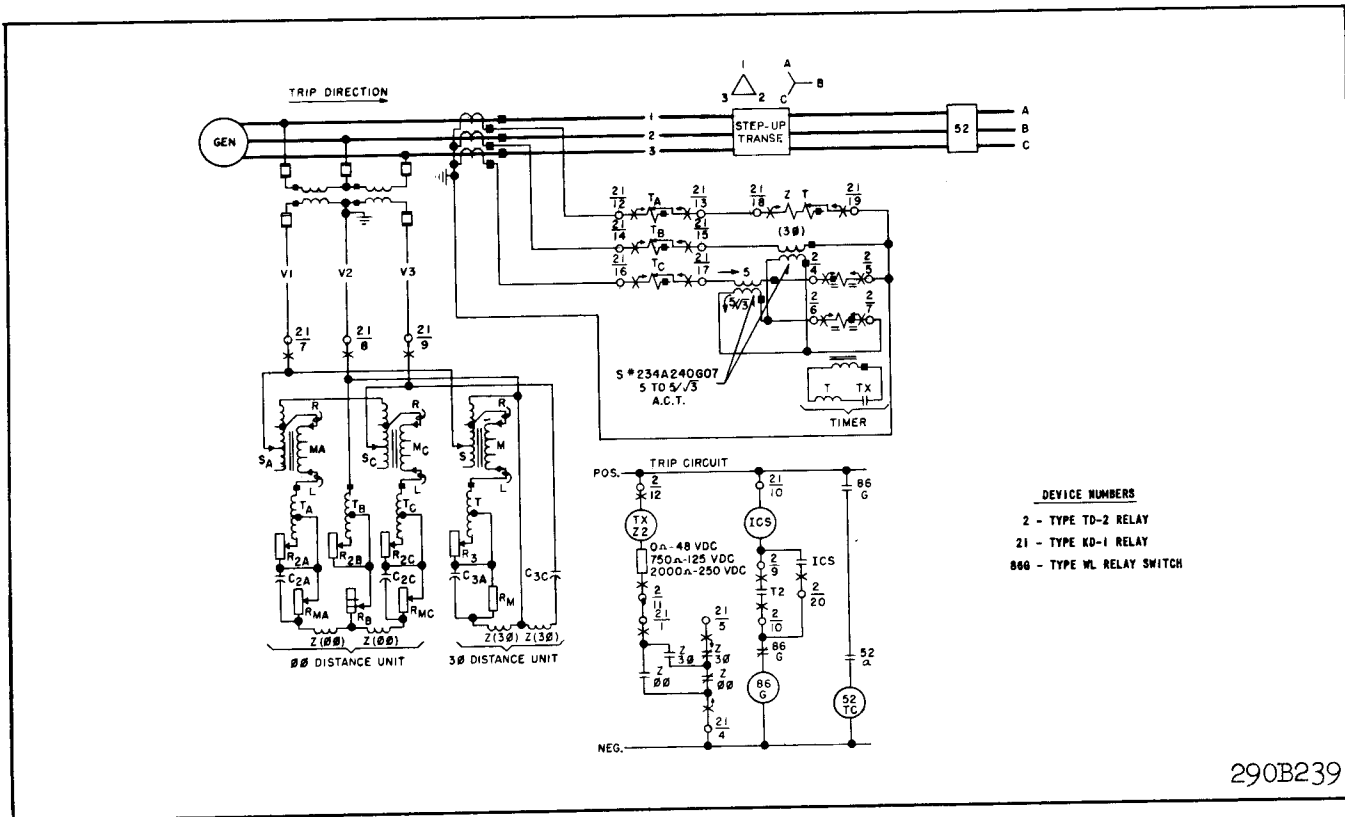

Fig. 23 External Schematic of Type KD-1 Relay with Type TD-2 Timing Relay for Generator Backup Protection.

fect, the main current transformer ratio is increased by a factor of two or three. Using the 2 to 1 ratio, the relay minimum reach setting is 0.375 ohms; with the 3 to 1 ratio the minimum setting is 0.25 ohms.

Fig. 23 shows a KD-1 and TD-2 relay connected for generator back-up protection.

Figs. 19 through 23 show the TD-2 relay; however, the TD-4 is equally applicable. In the case of Figs. 20, 21 and 23 the two S#234A240G07 auxiliary CT'S are not required if the TD-4 is used.

SWITCHBOARD TESTING WITH KD AND KD-1 RELAYS

Immediately prior to placing the relays in service, the external wiring can be checked by manipulating the current and voltage applied to the relay. If such a check is desired, refer to Appendix I for the procedure.

RECEIVING ACCEPTANCE

KD and KD-1 relays have a very small number of moving parts and mechanical devices which might become inoperative. Acceptance tests in general consist of:

1. A visual inspection to make sure there are no loose connections, broken resistors, or broken resistor wires.
2. An electrical test to make certain that the relay measures the balancepoint impedance accurately.

Distance Units

* Check the electrical response of the relay by using the test connections shown in Figure 24. Set T , T_A , T_B , & T_C for 5.8; S , S_A , S_C , & R_B for 1; M , M , & M for + 0.15

- A. Use connections for Test No. 1 and adjust the voltages V_{1F2F} and V_{2F3F} for 30 volts each.
- B. The current required to make the contacts close for the three-phase (bottom) unit should be between 3.44 and 3.6 amperes at the maximum-torque angle of 75° current lag. (Set phase shifter for 105° lag in Fig. 24)
- C. Use connection for Test No. 5.
- D. Adjust the voltage between PH.1 and 1F and

between PH.2 and 2F for 45 volts each so that the resultant voltage V_{1F2F} equals 30 volts. ($120-45V-45V=30V$)

- E. The current required to make the contacts close for the phase-to-phase (top unit should be between 2.95 and 3.05 amperes at an angle of 75° current lag.
- F. Repeat E while using connections for Test No. 6 and Test No. 7. The difference in values of current that make the contacts close for each of the three test connections should not be greater than 3% of the smallest value.

If the electrical response is outside the limits a more complete series of test outlined in the section titled "Calibration" may be performed to determine which component is faulty or out of calibration.

Indicating Contactor Switch (ICS)

Close the main relay contacts and pass sufficient d-c current through the trip circuit to close the contacts of the ICS. This value of current should be not less than 1.0 ampere nor greater than 1.2 amperes for the 1 ampere ICS. The current should not be greater than the particular ICS tap setting being used for the 0.2-2.0 ampere ICS. The operation indicator target should drop freely.

The contact gap should be approximately 0.047" for the 0.2/2.0 ampere unit and 0.070" for the 1.0 ampere unit between the bridging moving contact and the adjustable stationary contacts. The bridging moving contact should touch both stationary contacts simultaneously.

ROUTINE MAINTENANCE

The relays should be inspected periodically, at such time intervals as may be dictated by experience, to insure that the relays have retained their calibration and are in proper operating condition.

All contacts should be cleaned periodically. A contact burnisher #182A836H01 is recommended for this purpose. The use of abrasive material for cleaning contacts is not recommended because of the danger of embedding small particles in the face of the soft silver and thus impairing the contact.

Distance Units

CAUTION: Before making "hi-pot" tests, jumper all contacts together to avoid destroying arc-suppressor capacitors.

TYPES KD AND KD-1 RELAYS

Use connections for tests 1, 5, 6 & 7 of Fig. 24 to check the reach of the relay, or use a K-Dar Test unit for this purpose. When using test 1 of Fig. 24 the phase angle meter must be set for 30° more than the maximum torque angle. Note that the impedance measured by the 3-phase unit in test 1 is

$$Z_R = \frac{V_{L-L}}{\sqrt{3} I_L}$$

where V_{L-L} is the phase-to-phase voltage and I_L is the phase current; similarly, in tests 5, 6 & 7 of Fig.

24 the phase-to-phase unit measures $Z_R = \frac{V_{L-L}}{2I_L}$.

Indicating Contactor Switch (ICS)

Close the main relay contacts and pass sufficient d-c current through the trip circuit to close the contacts of the ICS. This value of current should be not less than 1.0 ampere nor greater than 1.2 amperes for the 1 ampere ICS. The current should not be greater than the particular ICS tap setting being used for the 0.2-2.0 ampere ICS. The operation indicator target should drop freely.

REPAIR CALIBRATION

Use the following procedure for calibrating the relay if the relay has been taken apart for repairs or the adjustments disturbed.

Connect the relay for testing as shown in Figure 24. The four-pole-double-throw switch shown in the test circuit selects the type of voltage condition, for a phase-to-phase or a three-phase fault, that will be applied to the relay voltage terminals. The rotary switch switches the fault voltage to various terminals and thereby simulates any combination of phase-to-phase faults without the tester having to change connections or readjust the phase shifter and variable auto-transformers.

For best results in checking calibration, the relay should be allowed to warm up for approximately one hour at rated voltage. However, a cold relay will probably check to within two percent of the warm relay.

Tripping Units

With the stationary contacts open so that the moving contact cannot touch, set the moving contact spring adjuster so that the contact floats freely in the gap. Make sure that there is no friction which prevents free movement of the cylinder and contact arm.

The upper pin bearing should be screwed down until there is approximately .025 inch (one complete turn of the screw) between it and the top of the shaft bearing. The upper pin bearing should then be securely locked in position with the lock nut. The lower bearing position is fixed and cannot be adjusted.

Autotransformer Check

Auto-transformers may be checked for turns ratio and polarity by using the No. 1 test connections of Figure 24, and the procedure outlined below.

Set S, S_A , and S_C on tap number 3. Set the "R" leads of M, M_A , and M_C all on 0.0 and disconnect all the "L" leads. Adjust the voltages V_{1F2F} and V_{2F3F} for 90 volts. Measure the voltage from terminal 8 to the #1 tap of S and S_A . It should be 30 volts. From 8 to the #2 tap of S and S_A should be 60 volts. The voltage should read 30 volts from 8 to $S_C = 1$ and 60 volts from 8 to $S_C = 2$.

Set S, S_A , and S_C on 1 and adjust V_{1F2F} and V_{2F3F} for 100 volts. Measure the voltage drop from terminal 8 to each of the M and the M_A taps. This voltage should be equal to 100 (1 + the sum of values between R and the tap being measured). Example: $100 (1 + .03 + .06) = 109$ volts.

Check the taps of M_C in the same manner. Transformers that have an output different from nominal by more than 1.0 volt probably have been damaged and should be replaced.

Distance Unit Calibration

Check to see that the taps on front of the tap block are set as follows:

T, T_A , T_B , and T_C set on 5.8

S, S_A , R_B , and S_C set on 1

"R" for M, M_A , and M_C set on 0.0

"L" for M, M_A , and M_C set in the top position ($.03 + .06 + .06 = .15$ between L & R).

I. Three-Phase Unit

A. Reactor X (KD relay) or Resistor R_M (KD-1 relay)

The procedure outlined below will assure a proper adjustment of the reactor. The reactor is adjusted to make the impedance angle of its own circuit equal to the impedance angle of the compensator secondary's circuit.

1. Connect the circuits of terminals 7 and 9 in parallel by disconnecting 1F from Brush No. 1 and connecting 1F to 3F in Figure 24.
2. Adjust Brush No. 2 for 105 volts between terminals 8 and 9. Voltage is zero between 7 and 9 because of the parallel connection. (105 volts is sufficiently high to detect small unbalancing and not high enough to cause saturation of the reactor.)
3. Adjust X or R_M for zero contact closing torque and a minimum of opening torque. Excessive opening torque tends to make the relay under reach at low voltages.
4. The core adjustment should be checked after any adjustment of X.

B. Core adjustment (KD relay only).

The lower cylinder unit of the KD relay contains an adjustable core which is set at the factory to give a biasing action that prevents contact closing on current-only. This adjustment can be checked by passing current in terminal 19 and out terminal 18. (The KD-1 relay is purposely biased to produced current-only contact-closing torque and will open its right hand contact at a current value of 3 amperes when T= 5.8).

1. Open the selector switch to a neutral position and short circuit terminals 7, 8 and 9 or 1F 2F, and 3F in Figure 24.
2. Pass 5 amperes in the current circuit and increase the current to 60 amperes in convenient steps. Adjust the core so that no contact closing torque is produced for all values of current. Do not bias the unit more than is necessary because excessive opening torque will tend to make the relay under reach at low voltages.
3. The Reactor X adjustment should be checked after any change in core adjustment.

C. Maximum torque angle adjustment.

1. Use the No. 1 test switch positions and lead connections as tabulated in Figure 24.
2. Adjust the voltages V_{1F2F} and V_{2F3F} for 50 volts with Brush No. 1 and Brush No. 2 respectively.
3. Adjust the current to 6 amperes and rotate the phase shifter to find the two angles, θ_1 and θ_2 , at which the bottom unit contacts just close.

The maximum torque angle θ for the three-phase unit then is $(\frac{\theta_1 + \theta_2}{2} - 30)$ degrees.

This angle should be between 73° and 76° for a nominal 75° adjustment. (Phase-shifter reading of 103° to 106° in Fig. 24)

4. A smaller angle may be obtained by reducing R_3 , in which case the test current should be equal to $\frac{6 \sin 75^\circ}{\sin \theta}$ amperes. The angle may be increased by increasing R_3 .

D. Contact Adjustment.

KD Relay: With moving-contact arm against right-hand backstop, screw the stationary contact in until it just touches the moving contact. (Check for contact by using an indicator lamp.) Then back the left-hand contact out two-thirds (2/3) of one turn to give 0.020-inch gap between contacts.

KD-1 Relay: With moving contact-arm against right hand side of bridge, screw the right-hand contact in to just touch the moving contact and then continue for one more complete turn. Adjust left-hand contact as described above, except back off one and one-half (1-1/2) turns to give approximately 0.047-inch gap.

E. Spring Restraint: Reconnect for a three-phase fault, Test No. 1, and set the phase shifter so that the current lags voltage by the maximum-torque angle. (105° in Fig. 24) Adjust the spring so that the current required to close the left-hand contact is as follows:

Voltages V_{1F2F} and V_{2F3F}	= 10 volts
Current to trip KD	= 1.27 amperes
Current to trip KD-1	= 1.3 amperes.

II. Phase-to-Phase Unit:

A. Rough Adjustment of R_{MA} and R_{MC}

Set R_{MA} to slightly less than half the adjustable range so that the adjustable band is nearer the center than the end.

1. Using connections for test #1 of Figure 24 adjust brush #1 so that $V_{1F2F} = V_{78} = 0$. Adjust brush #2 for rated voltage across terminals 8 & 9. Adjust R_B so that the contact floats or has a minimum of torque. This is a rough adjustment for making the impedance angle of phase 1 to be equal to impedance angle of phase 2.

2. Using test #1 of Figure 24, adjust brush #2 so that $V_{2F3F} = V_{89} = 0$. Adjust brush #1 for rated voltage across terminals 7 & 9. Adjust R_{MC} so that the contact floats or has a minimum of torque. This is a rough adjustment for making the impedance angle of phase 3 equal to the impedance of phase 2.

B. Maximum torque angle adjustment. Note that a change in the maximum torque angle adjustment may upset the calibration of the resistors R_{MA} and R_{MC} . Therefore, the R_{MA} and R_{MC} calibration should be checked after any change in the maximum torque angle. If there is an indication that the R_{MA} and R_{MC} adjustments should be changed due to a maximum torque angle adjustment re-calibration can be accomplished by adjusting R_B only.

1. Use the No. 2 Test switch positions and lead connections. This connection is for checking and adjusting the maximum torque angle of the phase-1 compensator.
2. Adjust the voltage V_{1F2F} and V_{2F3F} for 50 volts with Brush No. 1 and Brush No. 2 respectively.
3. Adjust the current to 10 amperes and rotate the phase shifter to find two angles, θ_1 and θ_2 , at which the top unit contacts just close. The maximum torque angle θ for the phase-to-phase unit then is $(\frac{\theta_1 + \theta_2}{2} - 30)$ degrees.

This angle should be between 73° and 76° when received from the factory.

4. The angle θ can be changed by adjusting R_{2A} . In this case, the test current should be equal to $\frac{10 \sin 75^\circ}{\sin \theta}$ amperes. A lower value of resistance gives a smaller angle and a higher resistance value gives a greater angle.
5. Use the No. 3. Test connections and repeat the procedures numbered 2, 3, and 4 to check and adjust the angle of the phase-2 compensators. Adjustments may be made by varying R_{2B} .
6. Use the No. 4 Test connections and repeat the above procedure to check and adjust the angle of the phase-3 compensator. This adjustment is made with R_{2C} .

C. R_{MA} and R_{MC} Calibration

These components serve the same purpose in the phase-to-phase unit circuit as the reactor X does in the 3-phase unit circuit. That is, R_{MA} and R_{MC} are adjusted so that their respective circuits have the same impedance angle as the circuit of the tapped-adjustable resistor R_B . These adjustments can be checked by simulating all three combinations of phase-to-phase faults, 1-2, 2-3 and 3-1, as shown in the test circuit Figure 24. Each value of current required to trip the top cylinder unit for each of the three conditions should be within 2% of the other two values when the circuits have been allowed to warm up with normal voltage applied to the relay terminals. An inaccurate setting R_{MA} or R_{MC} can cause the spread in current values to increase to more than 10%.

1. Connect the relay for a 1-2 fault as indicated for Test No. 5.
2. Adjust the voltage between Ph.1 and 1F and between PH.2 and 2F for 57.5 volts each using Brush No. 1 and Brush No. 2 respectively, to provide 5 volts between 1F and 2F ($V_{1F2F} = 120 - 57.5 - 57.5 = 5$ volts).
3. Adjust the phase shifter for θ degrees between load current and $V_{PH.1-PH.2}$.
4. With load current set for 0.53 amperes, adjust R_{MA} so that the top cylinder unit contacts just close.
5. Reconnect the relay for a 2-3 fault in Test No. 6 and adjust R_{MC} using procedures of steps 2, 3, and 4.
6. Determine the current value at which the contacts close for a 3-1 fault using Test No. 7. If the 3-1 fault current is greater than 0.53 amperes then R_{MA} is too low and R_{MC} is too high.
7. Increase R_{MA} a slight amount and reduce R_{MC} an equal amount until the contacts just close for 0.53 amperes.
8. Check the current required to close the contacts for Tests Nos. 5 and 6. The values should be equal to each other and to Test No. 7 within $\pm 3\%$.
- * 9: If the currents are not equal $\pm 3\%$ then use the average value for Tests Nos. 5 and 6 determined in step 8. and repeat steps 1 through 8. At first there may be an over-correcting or

pendulum action as one balances the R_{MA} and R_{MC} resistors. However, with a little experience the circuits can be balanced after two or three trials.

D. Spring Restraint.

1. Use Test No. 1 connections except reverse the voltage phase sequence by interchanging the Brush connections so that Brush 1 is connected to 3F and Brush 2 is connected to 1F.
2. Adjust the voltages V_{1F2F} and V_{2F3F} for 3.5 volts each with Brush No. 2 and Brush No. 1 respectively. Position the moving-contact spring adjuster so that the contact just floats and then return the circuit connections to normal with Brush 1 to 1F and Brush 2 to 3F.

E. Contact Adjustment

The procedure for contact adjustment for the phase-to-phase unit is identical to that described in section D for the three-phase unit.

* The phase-to-phase unit is now calibrated and should be accurate to within $\pm 3\%$ of the corrected tap value setting over the range of fault voltages from $5 V_{L-L}$ to $120 V_{L-L}$. The corrected tap value is actual relay reach at a given maximum torque angle θ and is equal to $Z_{\theta} = \frac{TS \sin \theta}{(1 \pm M) (\sin 75^{\circ})}$. The relay is now calibrated and ready for service.

III. Compensator Check

Accuracy of the mutual impedance Z_C of the compensators is set within very close tolerances at the factory and should not change under normal conditions. The mutual impedance of the compensators can be checked with accurate instruments by the procedure outlined below.

- A. Set T , T_A , T_B , and T_C on the 5.8 tap.
- B. Disconnect the "L" leads of sections M, M_A , and M_C and the brush leads of R_3 , R_{2A} , R_{2B} , and R_{2C} . (With resistor loading removed $\theta = 90^{\circ}$).
- C. Connect terminals 13 to 14, 15 to 16, 17 to 18 and pass 10 amperes a.c. current in terminal 19 and out of terminal 12.
- D. Measure the compensator voltage V_C with a high resistance voltmeter 5,000 ohm/volt as tabulated below. Refer to Figure 1 for the location of R_3 , R_{2A} , R_{2B} , and R_{2C} .

Measure V_C		Voltmeter Reading
From Terminal	To Fixed End of	
"L" of M	R_3	$V_C = 1.5 I T \left(\frac{\sin \theta}{\sin 75^{\circ}} \right)$ = 90.1 volts ($\theta = 90^{\circ}$)
"L" of M_A	R_{2A}	$V_C = I T \left(\frac{\sin \theta}{\sin 75^{\circ}} \right)$ = 60.1 volts ($\theta = 90^{\circ}$)
8	R_{2B}	
"L" of M_C	R_{2C}	

E. Any compensator that has an output which is 2 volts more or less than the nominal values given above should be replaced.

IV. Overall Check

After the calibration procedure has been completed, perform the following check.

A. Three-Phase Unit

Connect the relay for a three-phase fault, Test No. 1 of Figure 24, and set the phase shifter so that the phase angle meter indicates 30° more than the maximum torque angle. The current required to trip the relay should be within the limits specified for each of the voltages. Note that for the three-phase unit the impedance measured by the relay is $Z_R = \frac{V_{L-L}}{\sqrt{3} I_L}$

V_{L-L} is phase-to-phase fault voltage and I_L is phase current.

Volts	Amperes ($\theta = 75^{\circ}$) †† & †		
	I_{min}	I_{max}	
10	—	1.28	KD
		1.3	KD-1
30	3.44	3.6	KD
		3.65	KD-1
70	7.85	8.1	Both

† to determine the limits of current when θ is not equal to 75° multiply the nominal values tabulated above by the ratio $\frac{\sin 75^{\circ}}{\sin \theta}$.

†† Phase angle meter set for $\theta + 30^{\circ}$.

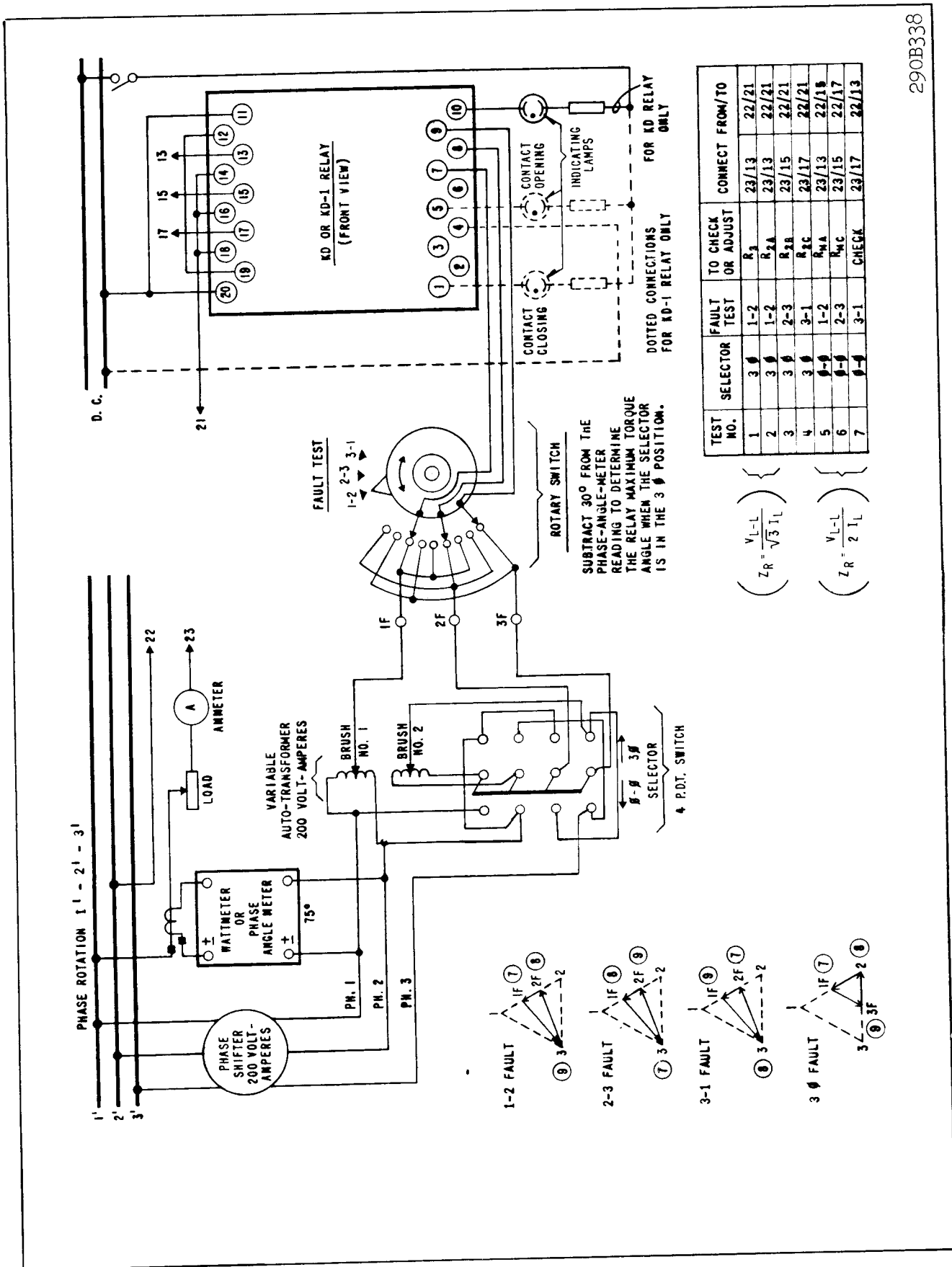

290B338

* Fig. 24 Test Connections for Type KD and KD-1 Relays.

B. Phase-to-Phase Unit

Using the connections for Tests Nos. 5, 6, and 7, set the phase shifter so that the current lags voltage by θ° . The current required to trip the phase-to-phase unit should be within the limits specified for each of the voltages. Note that for the phase-to-phase unit the impedance measured by the relay is $Z_R = \frac{V_{L-L}}{2 I_L}$ where V_{L-L} is phase-to-phase fault voltage and I_L is phase current.

Test No.	Volts	Amperes ($\theta = 75^\circ$)†	
	V_{1F2F}	I_{min}	I_{max}
5, 6 & 7	5.0	0.50	0.54
	30.0	2.95	3.14
	70.0	6.90	7.10

For both
KD & KD-1,
relays

† To determine the limits of current when θ is not equal to 75° , multiply the nominal values tabulated above by the ratio $\frac{\sin 75^\circ}{\sin \theta}$.

Indicating Contactor Switch (ICS)

Close the main relay contacts and pass-sufficient d-c current through the trip circuit to close the contacts of the ICS. This value of current should be not less than 1.0 ampere nor greater than 1.2 amperes for the 1 ampere ICS. The current should not be greater than the particular ICS tap setting being used for the 0.2-2.0 ampere ICS. The operation indicator target should drop freely.

The contact gap should be approximately 0.047" for the 0.2/2.0 ampere unit and 0.070" for the 1 ampere unit, between the bridging moving contact and the adjustable stationary contacts. The bridging moving contact should touch both stationary contacts simultaneously.

RENEWAL PARTS

Repair work can be done most satisfactorily at the factory. However, interchangeable parts can be furnished to the customers who are equipped for doing repair work. When ordering parts, always give the complete nameplate data.

TABLE I

NOMENCLATURE FOR RELAY TYPES KD AND KD-1

UNIT	ITEM	DESCRIPTION
THREE-PHASE	Z(3 ϕ)1-2	Two Element-Coils; Total d.c. Resistance = 360 to 390 ohms
	Z(3 ϕ)2-3	Two Element-Coils; Total d.c. Resistance = 680 to 740 ohms
	RM	2 Inch Resistor 1000 ohms Fixed for KD (3-1/2 inch 8500 ohm Adj. for KD-1)
	R ₃	2 Inch Resistor 600 ohms Adjustable
	C _{3A}	1.8 MFD Capacitor for KD (0.6 MFD for KD-1)
	C _{3C}	0.50 MFD Capacitor (0.6 MFD for KD-1)
	T	Compensator (Primary Taps - .87; 1.16; 1.6; 2.2; 3.0; 4.2; 5.8)
	S	Auto-Transformer Primary (Taps - 1; 2; 3)
	M	Auto-Transformer Secondary (Between Taps - 0.0; .03; .06; .06)
	X	Variable Reactor for KD (Not in KD-1)
PHASE-TO-PHASE	Z(ϕ - ϕ)	Two Element-Coils; Total d.c. Resistance = 560 to 600 ohms
	RMA	3-1/2 inch Resistor 2000 to 3000 ohms adjustable
	RMC	
	R _B	2 inch Resistor Fixed-adjustable Taps at 30 & 55 ohms; adjustable 55 to 385 ohms
	R _{2A} , R _{2B} , R _{2C}	2 inch Resistor 600 ohms Adjustable
	C _{2A} , C _{2C}	1.6 MFD Capacitors
	T _A , T _B , T _C	Compensators Same As T
	S _A , S _C	Same As S
	M _A , M _C	Same As M

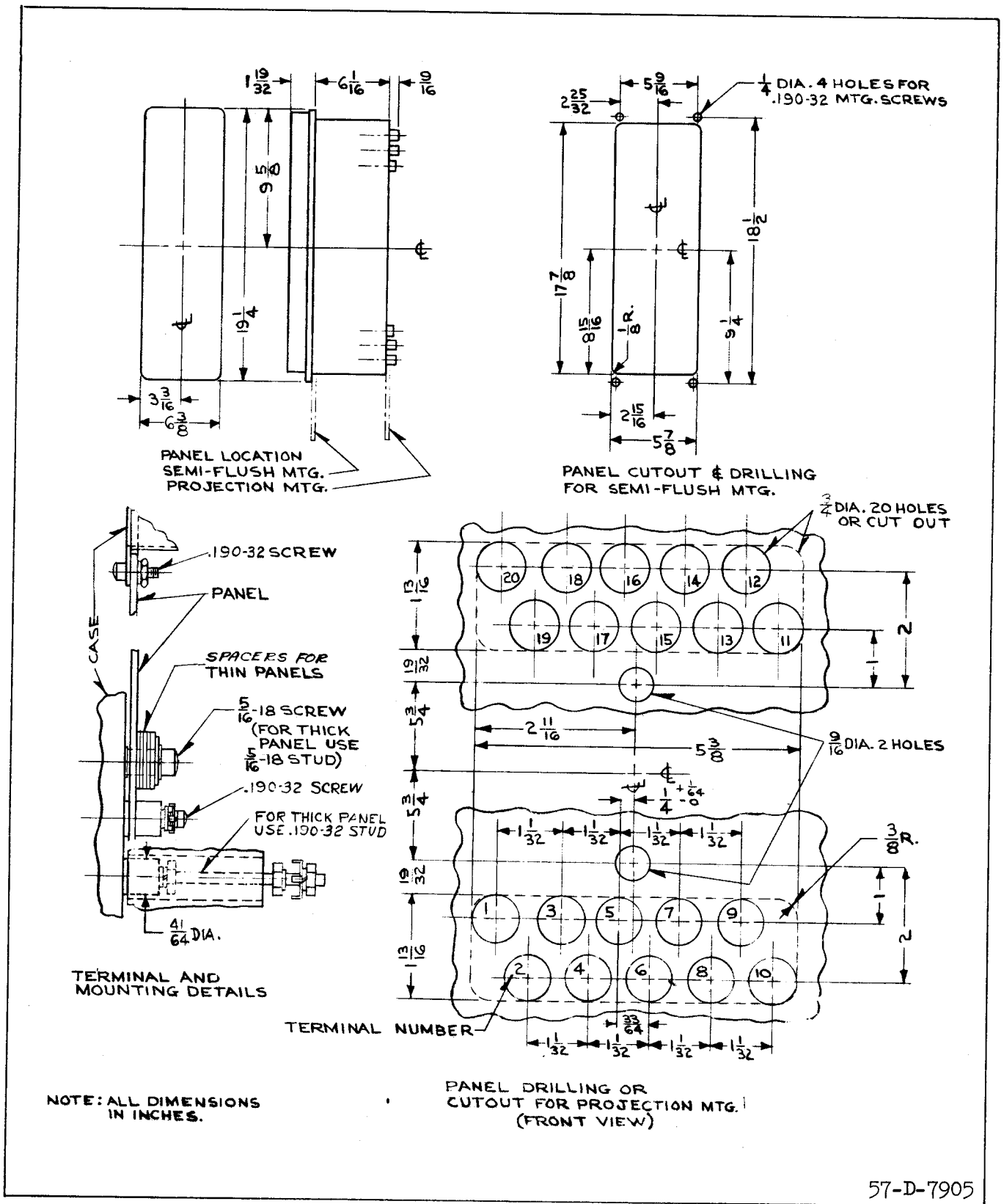

Fig. 25 Outline and Drilling Plan for the Type KD and KD-1 Relays in the Type FT42 case.

APPENDIX I

SWITCHBOARD TESTING WITH KD AND KD-1 RELAYS

External connections may be checked by the relay, provided there is sufficient load current flow at a known power factor angle. Relay current must be at least $\frac{7}{T}$ amperes (1.2 amps. when $T = 5.8$). This check is appropriate prior to commissioning the relay or when trouble shooting.

Potential Circuit Check

Close the three relay potential switches numbered 7, 8, and 9, (Figure 17). The connection for the proper phase sequence will be indicated by a strong contact-opening torque. Closing torque will indicate reverse-phase sequence.

Current Verification

To verify the proper current connections use the following procedure:

1. Read watts, vars and amperes. The current should be at least 1.2 amperes.
2. Plot watts and vars on the diagram in Fig. 26. Draw a line at the load angle determined by this plot. Designate this line as I_{REF} . See Fig. 27 for example.
3. Set $T = 5.8$, $S = 1$ for maximum sensitivity. (Lower taps may be used, provided current exceeds $7/T$).
4. Perform the 9 switching combinations in Table II, recording the relay contact position for each combination. (Actually only 6 combinations are needed to verify the currents, so that any group of three need not be used. This is important where the load angle falls too close to the zero torque line. If the indicated power-factor angle is within 3° of the test limit for any group of three tests, these should be ignored.)
5. Verify the currents using the procedure illustrated in Table III. Here the "correct contact position" is determined by observing whether the I_{REF} line in Fig. 27 intersects the solid or dashed part of circle. (For example, test 1b shows a solid circle indicating that the contacts should close.) Next compare the actual contact positions to the correct ones.
6. If the contact positions are proper, the current connections are correct and the test is complete, otherwise proceed to identify the

currents using the following procedure.

Current Identification

If the verification check discloses incorrect current connections, the following procedure may be used to determine what is wrong. However, if one set of three switching combinations places the relay too close to the zero-torque line, use conventional techniques instead, since identification requires all 9 switching combinations.

1. Plot aI_{REF} and a^2I_{REF} at 120° angles from I_{REF} . See Fig. 27 for example. These currents are related to the phase currents as shown in the following table:

Phase Receiving Current	I_{REF}	a^2I_{REF}	aI_{REF}
1	I_{PH1}	I_{PH2}	I_{PH3}
2	I_{PH2}	I_{PH3}	I_{PH1}
3	I_{PH3}	I_{PH1}	I_{PH2}

2. Prepare a table similar to Table IV using Fig. 27. For example, for test 1b the contacts were open. Such a result would occur if I_{REF} of the wrong polarity is actually flowing in the phase 1 circuits of the relay. This conclusion is drawn by noting that I_{REF} in Fig. 27 intersects the solid part of the test 1b circle. This says that if $+I_{REF}$ is flowing the contacts would close. Since the contacts actually open, then $-I_{REF}$ could be flowing. Similarly, for test 1b, $-a^2I_{REF}$ could be flowing, since the a^2I_{REF} line also intersects the solid part of the test 1b circle.

By the process of elimination for each set of 3 tests, the actual current is identified. For example, in Table IV, phase 1 receives $-I_{PH1}$, whereas $+I_{PH1}$ should be flowing. In phase 2, $+I_{PH3}$ is flowing as shown in Fig. 28. To extract this bit of information from Table IV, use the above table relating the phase currents to I_{REF} , a^2I_{REF} and aI_{REF} .

Note in Table IV that a^2I_{REF} is flowing in the phase 2 circuits of the relay. The above table shows for this set of 3 tests that $a^2I_{REF} = I_{PH3}$.

3. Correct the external connections and then verify the currents.

TABLE II

SWITCHING FOR CURRENT VERIFICATION AND IDENTIFICATION

Switching Combination	Position of switches numbered:							Unit which should be Observed	Phase Receiving Current
	Voltage sw.			Current sw. (blank indicates open sw.)					
	V ₁	V ₂	V ₃	I ₁	I ₂	I ₃	I ₁		
	7	8	9	12, 13	14, 15	16, 17	18, 19 (3φ)		
1	Open & jump sw. jaw to 9	Closed	Closed	a		Closed		φ-φ&†	3
				b	Closed		Closed	φ-φ& 3φ	1
2	Closed	Open & jump sw. jaw to 7	Closed	a	Closed		Closed	φ-φ& 3φ	1
				b		Closed		φ-φ&†	2
3	Closed	Closed	Open & jump sw. jaw to 8	a		Closed		φ-φ&†	2
				b			Closed	φ-φ&†	3
4	Closed	Closed	Open & jump sw. jaw to 7	Closed			Closed	φ-φ& 3φ	1
5	Open & jump sw. jaw to 8	Closed	Closed		Closed			φ-φ&†	2
6	Closed	Open & jump sw. jaw to 9	Closed			Closed		φ-φ&†	3

† Block 3 φ Unit Open

†† 3 φ unit operation is based on the relay looking into the line. For carrier applications with KD-1 looking in the reverse direction, the contacts should be in the opposite positions from those listed in the table.

TABLE III

VERIFICATION EXAMPLE USING ASSUMED LOADING OF FIG. 27

PHASE TO BE VERIFIED	SWITCHING COMBINATION	CORRECT CONTACT POSITION	ACTUAL CONTACT POSITION	
			IF WIRING IS CORRECT	EXAMPLE WITH INCORRECT WIRING
1	1b	C	C	O
	2a	C	C	O
	4	O	O	C
2	2b	C	C	C
	3a	C	C	O
	5	O	O	C
3	3b	C	C	O
	1a	C	C	O
	6	O	O	O

TABLE IV

IDENTIFICATION EXAMPLE USING ASSUMED LOADING OF FIG. 27

I _{REF.} PHASE RECEIVING CURRENT	SWITCHING COMBINATION	EXAMPLE OF CONTACT POSITION	CURRENT & POLARITY WHICH CAN PRODUCE OBSERVED CONTACT POSITION		
			I _{REF.}	a ² I _{REF.}	a ¹ I _{REF.}
1	1b	O	<div style="border: 1px solid black; padding: 2px; display: inline-block;">-</div> †	-	+
	2a	O		+	+
	4	C		+	-
2	2b	C	+	<div style="border: 1px solid black; padding: 2px; display: inline-block;">+</div> †	-
	3a	O	-		+
	5	C	-		-
3	3b	O	-	-	<div style="border: 1px solid black; padding: 2px; display: inline-block;">+</div> †
	1a	O	-	+	
	6	O	+	-	

† See Fig. 28 for actual connections.

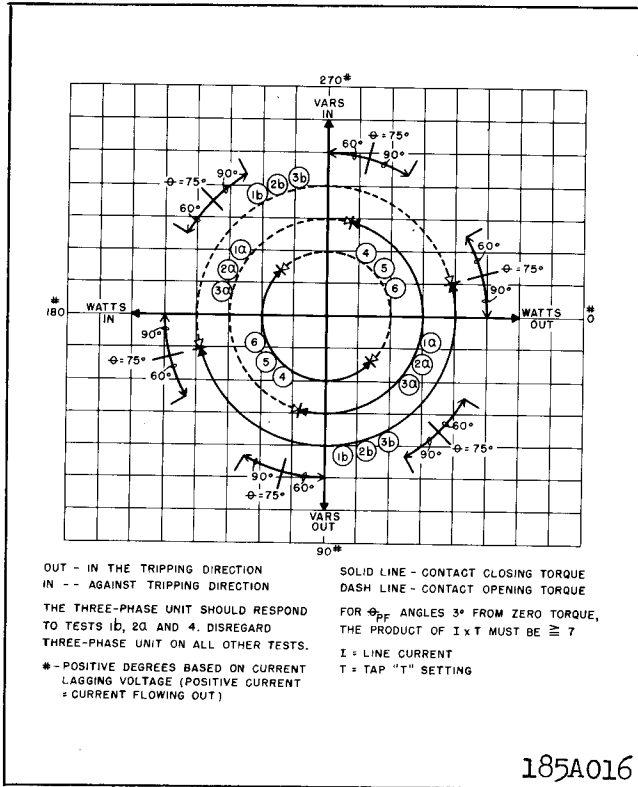

Fig. 26 Phase diagram for Current Circuit Verification and Identification

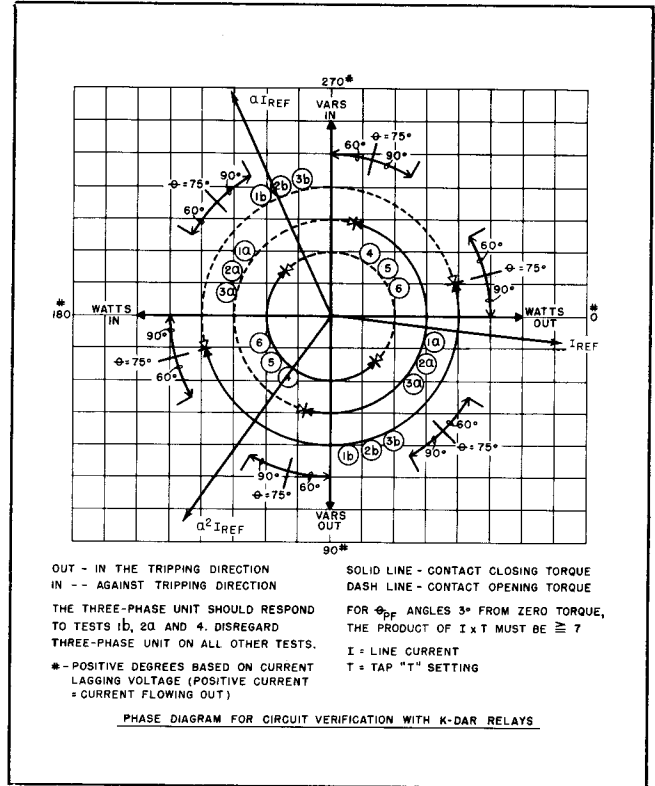

Fig. 27 Phase Diagram Showing Assumed Load Conditions for an Example

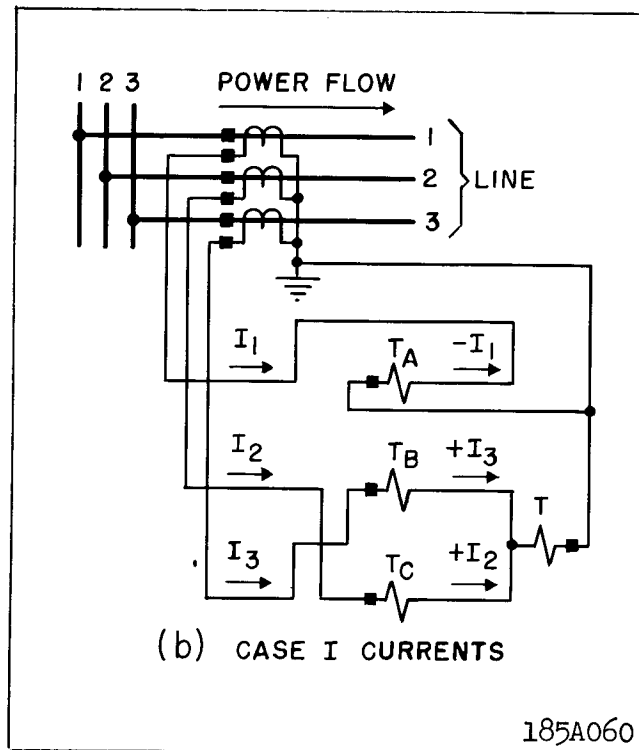
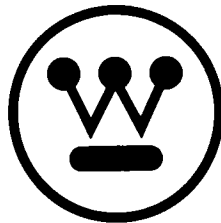

Fig. 28 Actual Wiring for the Assumed Test Results of Table IV



WESTINGHOUSE ELECTRIC CORPORATION
RELAY-INSTRUMENT DIVISION

NEWARK, N. J.

Printed in U.S.A.