



# INSTALLATION • OPERATION • MAINTENANCE INSTRUCTIONS

## TYPE HZM DISTANCE RELAY (WITH ANGULAR DISPLACEMENT 60° TO 90°)

**CAUTION** Before putting protective relays into service, remove all blocking inserted for the purpose of securing the parts during shipment. Make sure that all moving parts operate freely. Inspect the contacts to see that they are clean and close properly, and operate the relay to check the settings and electrical connections.

### APPLICATION

The type HZM relay is a three element high speed relay of the modified zoned distance type operating instantaneously or with a time delay depending upon the location of the fault. The relay is used for phase fault protection on transmission systems and is designed to be used independently or in the high speed carrier relaying system.

The type HZM relay measures the impedance of the line to which it is connected by measuring the ratio of the current and voltage supplied to it. The impedance characteristics may be adjusted and modified so that tripping at the faulted line angle is favored to permit tripping on fault impedances when it is desirable to do so while preventing tripping out on synchronous surges of such magnitude that the system will recover, even though the apparent impedance during such surges is considerably below that of the fault impedance. In the same manner tripping under heavy load conditions may be prevented, especially on the longer transmission lines, when the load impedance and the fault impedance are of the same magnitude. The type HZM relay accomplishes this by combining a distance response characteristic with a directional discrimination which can be regulated and adjusted both in magnitude and angle. The directional discrimination is adjusted to produce a high sensitivity at the fault impedance

phase angle but a minimum sensitivity at the load impedance phase angle and at the synchronous surge impedance phase angles from which the system can recover. Therefore this relay with its adjustable characteristics can be set to fit the particular conditions of the line to be protected.

### CONSTRUCTION

The type HZM relay contains three impedance elements, a synchronous timer, a directional element, four auxiliary contactor switches and three operation indicators, one for each impedance zone. In addition there is an external box with a phase shifter and mixing transformer for each impedance element.

#### Impedance Element

Construction details of these three elements are identical and are shown in Fig. 1. A balanced beam is restrained from operating by two voltage coils on the back end, and is pulled downward on the front contact end by a current coil. The fluxes of these two potential coils are shifted out of phase so that practically a constant balance can be obtained regardless of the phase angle between the current and voltage fluxes. A tap screw on the front of the element permits changing the number of turns on the current coil for coarse adjustments and a core screw on the bottom of the element changes the current coil electromagnet air gap for the fine adjustment. These two adjustments provide stepless impedance circle radius settings over the one ohm to ten ohms impedance range.

The silver moving contact is of the low-bounce type while a beam shock absorber is mounted on each of the impedance element beams to reduce the vibration of the moving element and to act as a counterweight.

SUPERSEDES I.L. 41-412.1 J

\* Denotes change from superseded issue.

EFFECTIVE MAY 1954

## TYPE HZM RELAY

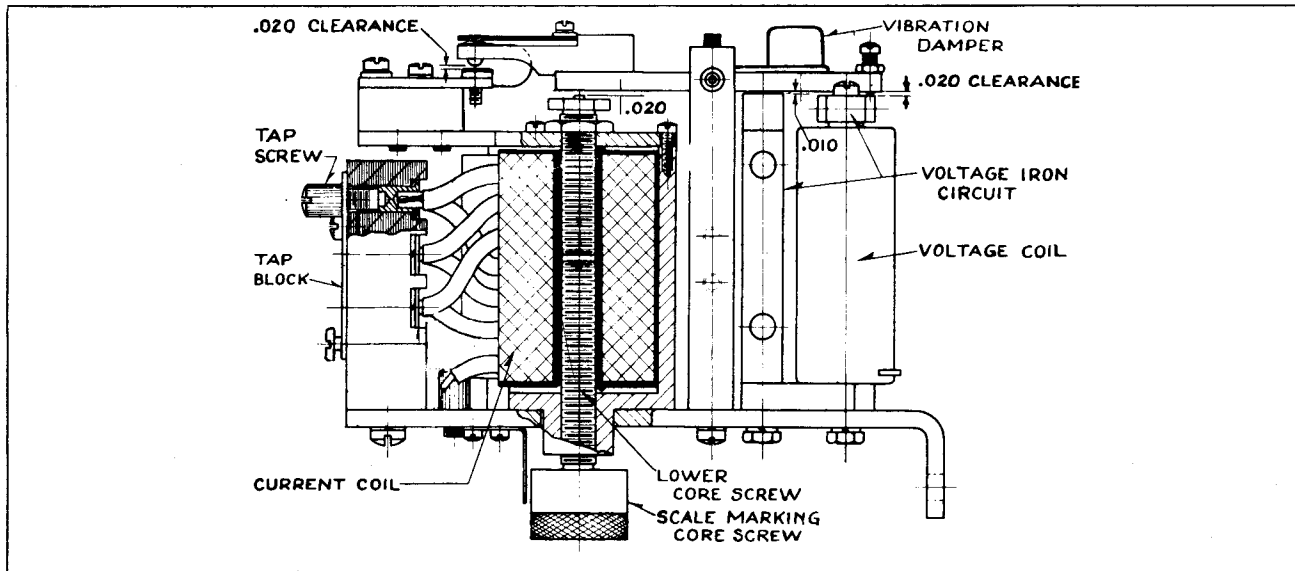

Fig. 1—Sectional View of the Impedance Elements.

### Synchronous Timer

The timer is a small synchronous motor which operates from the current circuit thru a saturating transformer, and drives a moving contact arm thru a gear train. The contact on the moving arm is a cylindrical silver sleeve, loosely fitted on the moving arm. In making contact, this sleeve rolls across two vertically projecting stationary butt contacts to bridge the gap between them. Two sets of stationary contacts are mounted on Micarta insulating blocks which are adjustable around a semi-circular calibrated guide. The maximum time setting of the timer is three seconds.

The synchronous motor has a floating rotor which is in mesh with the gear train only when energized. The rotor falls out instantly when the motor is deenergized, allowing a spring to reset the moving arm.

### Directional Element

The directional element is made up of five basic parts: the die-cast aluminum frame, the moving element assembly, and the bridge and upper bearing pin assembly. The lower bearing pin, the adjustable stops for the moving element and the magnetic core with its adjustment

lever are mounted on the frame. The electromagnet has two series connected voltage coils mounted diametrically opposite one another and two series connected current coils mounted diametrically opposite one another. The moving element consists of a spring and contact arm assembly and a double aluminum loop mounted on a shaft which has end jewels for the top and bottom bearings. This shaft rides between the bottom steel bearing pin mounted in the frame and a similar pin in the bridge that mounts on the two longer studs of the electromagnet. The spring adjuster seats on the molded cover and is attached to the contact through a spiral spring. The moving contact is made of two thin-walled silver shells practically filled with tungsten powder and mounted back to back on a thin leaf spring. The stationary silver contacts are mounted on the molded cover. The electrical connection is made from the stationary contact to the moving contact, through the spiral spring and spring adjuster to the spring adjuster clamp.

### Auxiliary Contactor Switches

These are small solenoid-type d-c switches. A cylindrical plunger with a silver disc mounted on its lower end moves in the core of the solenoid. As the plunger travels upwards, the disc bridges three silver stationary contacts.

Operation Indicator

The operation indicator is a small solenoid coil connected in the trip circuit. When the coil is energized, a spring-restrained armature releases the white target which falls by gravity to indicate completion of the trip circuit. The indicator is reset from outside of the case by a push rod in a cover or cover stud.

Auxiliary Box

The type HZM auxiliary box contains nine identical phase shifting and transformer units connected so as to modify the characteristics of nine relay impedance elements. All the units function independently so that the characteristics of each impedance element may be modified independently of the other impedance elements.

The addition of an external modifying auxiliary box makes it possible to displace the impedance circle characteristic of the impedance element as plotted on "R" and "X" coordinates, from a circle with the center at the origin to a circle with the center displaced from the origin. The center of the impedance circle may be angularly displaced 60° to 90° in current lag angle and the center may be displaced in magnitude by the settings of the taps on the auxiliary box.

OPERATION

The type HZM distance relay is designed to provide a modified operating characteristic that gives improved protection to long transmission lines. The relay consists of two units, the conventional impedance relay and an auxiliary box.

The impedance relay measures the impedance of the line to which it is connected by measuring the ratio of the current and voltage supplied to it. The relay is connected to receive a current and voltage proportional to those existing on the high-tension line. With a fault in zone 1, Fig. 5, a given amount of current, I, will flow from the relay location to the fault. With zero voltage existing at the fault, the voltage at the relay must be

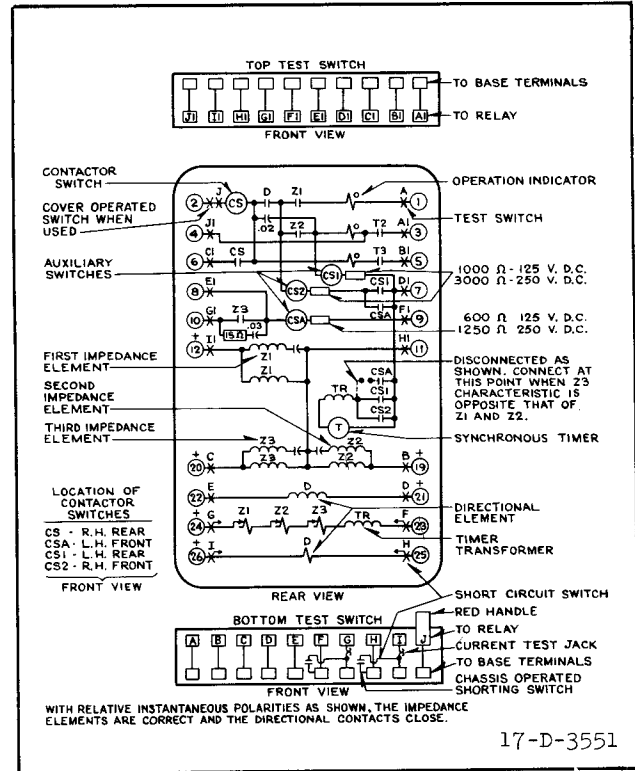
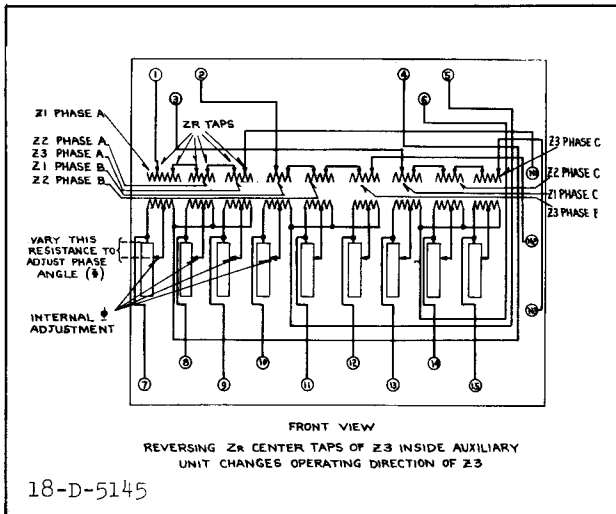

Fig. 2—Internal Schematic of the Type HZM Relay with HL-2 Directional Element in the Type FT Case. Omit Test Switches for the Relay in the Standard Case.

equal to the drop in the line due to the current, I, or equal to IZ where Z is the impedance to neutral of the line from the relay to the point of fault. The ratio of the two values is  $IZ/I = Z$ . Thus, the ratio is constant for any value of current as the voltage on the relay is equal to the current times the line impedance. Therefore, if the first impedance element of the type HZM relay is adjusted by the core screw and taps on the current coil for a value of current such that the pull of the current coil is just equal to the potential restraint for a fault at the end of zone 1 in Fig. 5, the beam will be balanced for a fault at that point for any value of current. Now, if the fault occurs to the right of this balance point, the beam will not trip as the voltage pull is the greater due to a larger amount of impedance and correspondingly larger potential restraint than the beam is balanced for. The second impedance element is adjusted to balance for a fault at the end of zone 2, and, therefore operates for faults anywhere up to this point. Likewise,

# TYPE HZM RELAY

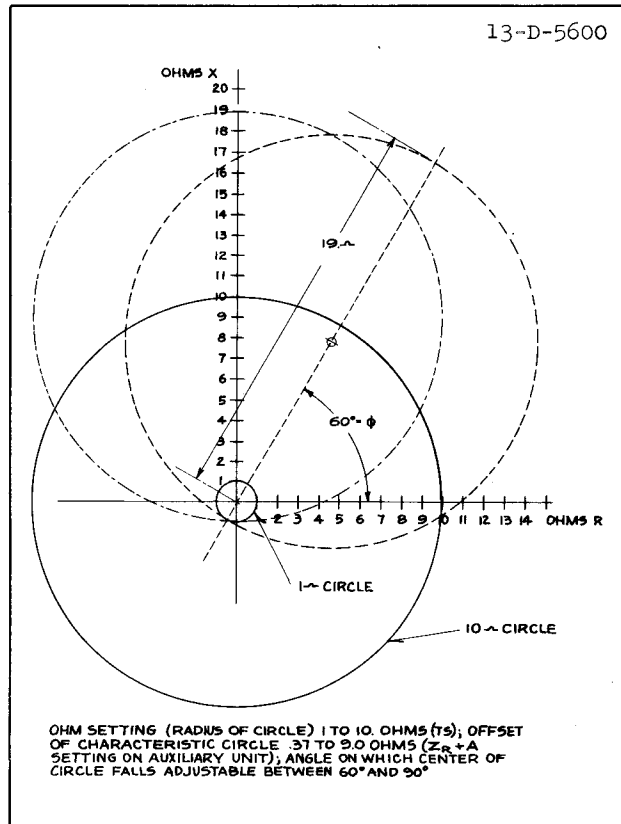

**Fig. 3 - Internal Schematic of the Nine Element Auxiliary Unit for the Type HZM Relay.**

the third impedance element is adjusted to balance for a fault at the end of zone 3 and operates for faults in all three zones.

The type HZM relay is a modified impedance relay that is identical to the conventional balanced beam impedance relay except that the restraint is produced by the potential and the current instead of by potential alone. The mixing of the current and the potential energy to produce restraint torque is done external to the relay and the resultant energy is fed into potential coils of the beam impedance element.

In the directional element, torque is produced by the interaction of current and voltages fluxes which develop forces on the two aluminum loops. The resulting torque is substantially free of vibrations, because the double-frequency torques that are produced on the two loops are equal and opposite in sign. The magnetic design of the element is such that the maximum torque occurs when the current leads the voltage 35 to 40 degrees. This is the condition at which the voltage and current fluxes are 90° apart. The flux in each pole face is lagged on the outside edges. This produces a torque that counter-balances the centering torque, caused by the small power factor angle of the moving element. The adjustable magnetic bias which is built into the core controls the distribution of the



**Fig. 4 - Operating Characteristics and Ranges of the Type HZM Relay.**

fluxes so that the electrical center of the element may be shifted to give optimum operating conditions.

The trip circuit for each of the three zones differs depending upon whether the third impedance element is connected so that its characteristics are similar to those of the first and second impedance elements or its characteristic is directionally reversed, which is done usually in carrier applications.

With the normal third impedance element, trip circuits for the three zones consist of the following contacts: First zone - directional, and first impedance element contacts; Second Zone - directional, second impedance, and first set of timer contacts; Third zone - second set of timer contacts.

The coil of contactor switch CS is in series with all of the tripping circuits and with the trip coil of the breaker. If the type HZM relays are used without carrier the contactor switch contacts seal around the relay contacts

# TYPE HZM RELAY

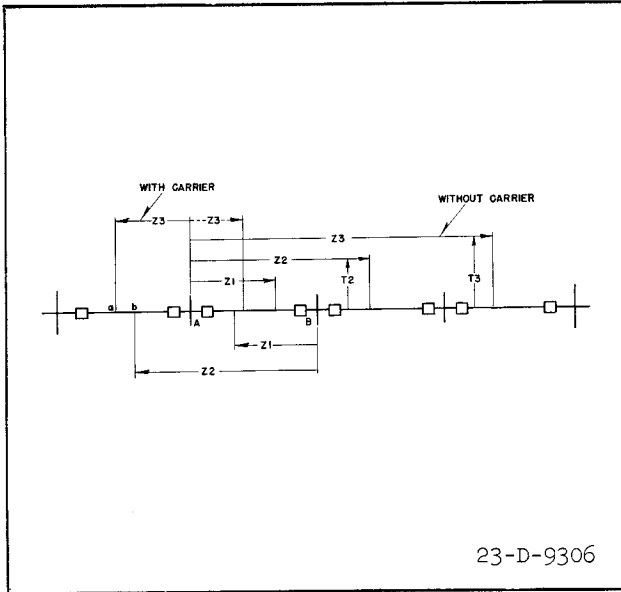

**Fig. 5 Typical Settings of the Type HZM Relay in Terms of Line Length.**

when the trip circuit coil is energized thereby relieving them of the duty of carrying the tripping current (Fig. 8). These contacts remain closed until the trip circuit is opened by the auxiliary switch on the breaker.

## CHARACTERISTICS

The modified characteristic is shown in Fig. 4. A pure impedance element characteristic plotted on the "r" and "X" coordinates is a circle with the center at the origin. The type HZM relay is so designed that it is possible to displace the center of any impedance circle from the axis over an angle from 60° to 90° current lag.

There are three variables that can be controlled to fit the transmission line protection requirements making the modified impedance relay very flexible in its applications.

1. The radius of the impedance circle on the "R" and "X" coordinates is entirely determined by the tap (T) and core screw (S) settings of the impedance element.

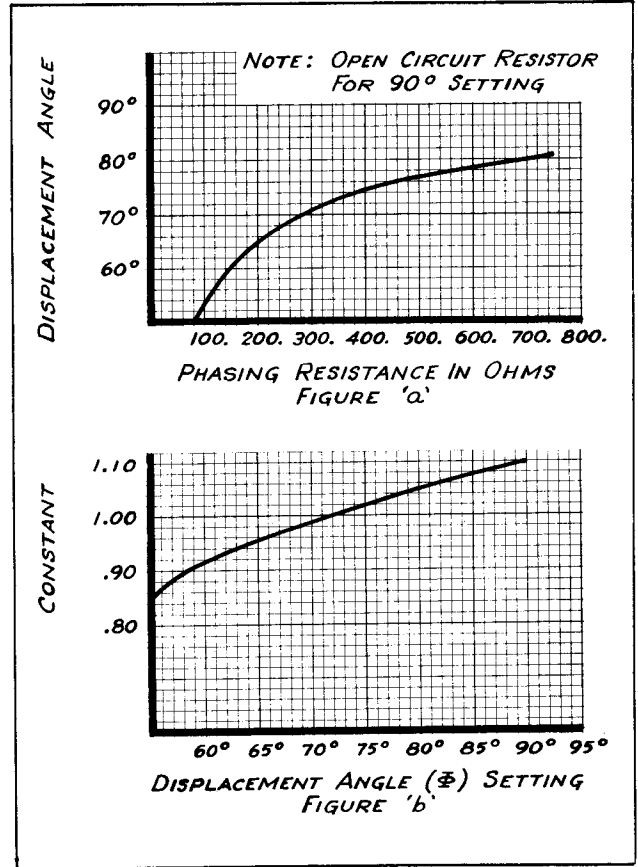

**Fig. 6 -Adjustment Curve for the Angular Displacement of the Operating Circle Center by Varying Auxiliary Box Internal Resistor.**

2. The magnitude of displacement of the center of the impedance circle from the origin is determined by the auxiliary box current transformer primary tap. ( $Z_R + A$ ).

3. The angle of displacement of the impedance circle can be varied from 60° to 90° current lag by the auxiliary box phase angle adjustment ( $\phi$ ).

The type HZM relay is available in one impedance range 1.00 to 10.0 ohms impedance circle radius (TS) with .37 to 9.0 ohm impedance circle center displacement ( $Z_R + A$ ) over a phase angle from 60° to 90° current lag ( $\phi$ ). All three impedance elements are identical and hence have the same range of adjustment. The tap and scale marking on the relay elements are as follows: (All impedances are in terms in secondary ohms).

# TYPE HZM RELAY

## Impedance Elements (1.0 to 10.0 Ohms)

Radius of Impedance Circle

### TAPS (T)

6.2 9.4 13.5 20.8 29.8 45.

### Core Screw Markings (S)

1.4 1.6 1.8 2.0 2.2

## Auxiliary Box

Displacement of impedance circle.

### Coarse Ohm Taps ( $Z_R$ )

0.0 1.9 3.7 5.6 7.5

### Fine Ohm Taps (A)

0.0 .37 .75 1.1 1.5

### 3. Phase Angle Displacement ( $\theta$ )

60° to 90° Current Lag

The Phase Angle of Displacement is normally set at 75° unless otherwise specified.

The time delay on the synchronous timer for the second and third impedance elements is adjustable in calibrated steps of 20 cycles from 0 to 180 cycles (60 cycle basis).

### Minimum Voltage Requirement

The minimum length of line to which the type HZM relay can be applied must be long enough to produce at least

$$10 + \frac{100 (Z_R + A)}{TS} \text{ volts on}$$

the relay when a short circuit exists at the balance point and minimum short-circuit current is flowing. If the voltage becomes much less than this value the forces become too small to assure fast and positive action.

## SETTINGS

The type HZM relay requires a setting for each of the three impedance elements and on the synchronous timer for Second and Third Zone time.

Z = line-to-neutral ohmic impedance of the protected line from the relay to the desired balance point in terms of primary ohms.

For the First Element 70 to 80% of the protected section.

For the Second Element Approx. 50% into the adjacent section.

For the Third Element Approx. 25% into the third line section (without carrier).

When carrier is used, see the following section entitled "HZM Carrier Setting of Z3".

When the balance impedance has been determined, the phase angle and magnitude of the minimum load ohms and the phase angle and magnitude of the minimum synchronizing surge ohms from which the system can recover should be determined or estimated to complete the analysis.

It will expedite the application by plotting the transmission line characteristics on "R" and "X" coordinates. An operating circle should then be drawn of a diameter and location to fulfill the following conditions:

1. The circle must pass through the point of the vector Z and must completely enclose the vector Z.

2. The circle must not enclose the point of the vector of minimum load ohms or of minimum synchronizing surge ohms from which the system can recover.

3. The angular displacement of the center of the circle must be within 60° to 90° current lagging phase angle.

After the operating circle for relay action has been obtained, it is necessary to adjust the relay characteristics to match this circle.

The radius of the circle in ohms should be measured and the impedance element set in accordance using the formula:

$$TS = \frac{10Z_o R_c}{R_v}$$

where

T = The impedance element current tap value.  
 S = The impedance element current core screw value. The values appear as a series of dots on the drum of the lower core screw adjusting knob.

Z<sub>o</sub> = Radius of circle, as determined in the preceding paragraphs, in ohms primary.

R<sub>c</sub> = The current transformer ratio.

R<sub>v</sub> = The potential transformer ratio.

The tap, T, is obtained by dividing the TS produce by S to give an available tap number. When changing taps with the relay energized, the extra tap screw should be screwed in the desired tap before removing the existing tap screw to prevent open circuiting the current transformers.

The numbers on the core screw appear in ascending order as the core screw is screwed into the core. In some cases, a question of doubt may arise whether the scale setting is correct, or is out by one full turn of the core screw. In such a case, the point may be verified by turning the core screw all the way in. Then back out the core screw until the highest scale marking just comes under the end of the pointer. This will occur in approximately one turn. Then turn to correct setting. Sufficiently accurate setting can be made by interpolating between the marked points when necessary.

From the operating circle, previously constructed, measure the displacement of the center of the circle from the intersection of the "R" and "X" axis in magnitude and angle.

The auxiliary box should be set in accordance with the formula:

$$Z_R + A = \frac{Z_D R_C}{R_K V}$$

( $\phi$ ) = Angular displacement of center of operating circle. This setting is made by varying the resistance of the resistor located as shown in Fig. 3 in the auxiliary box in accordance with the curve of Fig. #6a to obtain the displacement of angle ( $\phi$ ) desired. The phase angle of displacement is normally set at 75° unless otherwise specified.

where

Z<sub>R</sub> = Auxiliary box tap value.

A = Auxiliary box tap value.

Z<sub>D</sub> = Displacement of the center of the operating circle in ohms primary.

K = Constant determined from curve Fig. #6b.

R<sub>c</sub> = The current transformer ratio.

R<sub>v</sub> = The potential transformer ratio.

When changing the Z<sub>R</sub> or A tap with the relay energized, the current terminals of the auxiliary box should be shorted before unscrewing the tap screw to prevent open circuiting the transformers.

The formula settings are sufficiently accurate for most installations. Where it is desired to set the balance point more accurately the tap and scale values may be checked by applying to the relay and the auxiliary box, the voltage, current, and phase angle conditions which will be impressed on it for a fault at the desired balance point. A slight change in the scale value or in the auxiliary box setting from that calculated may be required so that the relay will just trip for the simulated fault at the balance point.

As an example of the formula setting, set the first impedance element to protect a 78°, 110 KV, 60 cycle line, 143 miles long. The line-to-neutral impedance is .79 ohm per mile. The current transformer ratio is 600/5, and the potential transformer ratio is 1000/1. The first element is to protect 80% of the line section or for a balance point .80 x 143 x .79 = 90 ohms. The phase angle and the

# TYPE HZM RELAY

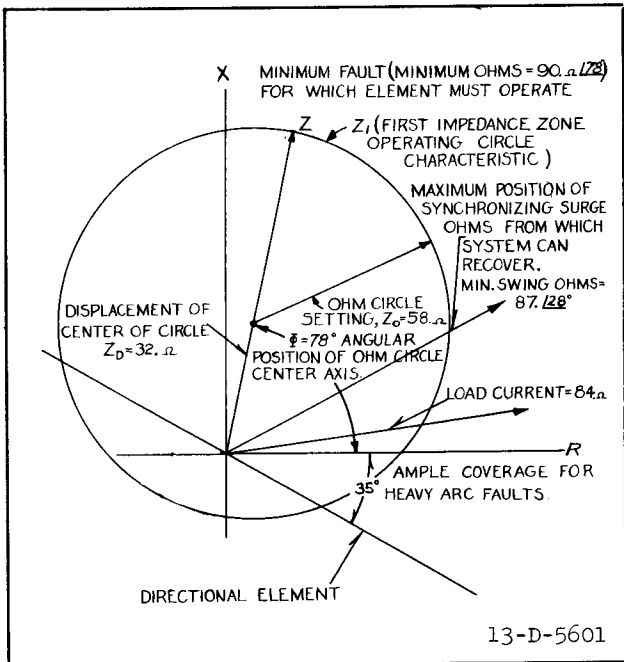

Fig. 7 -Transmission Line and Relay Characteristics Plotted on R and X Coordinates in Primary Ohms.

magnitude of the minimum synchronizing surge ohms from which the system can recover should be determined.

Plot the transmission line characteristics on "R" and "X" coordinates as shown in Fig. 7. An operating circle should then be drawn of a diameter and location to fulfill the conditions previously stated.

The radius of the circle in ohms should be measured and the impedance element set in accordance using the formula:

$$TS = \frac{10Z_o R_c}{R_v}$$

$$TS = \frac{10 \times 58.0 \times 600/5}{1000/1} = 69.6$$

T will be set on 45 (Relay Tap Setting)

S will be set on 1.55 (Relay Core Setting)

The lag angle of the center of the circle should be measured and the internal phase angle adjustment on the auxiliary box should be set to this angle by adjusting the resis-

tance of the internal resistors (see Fig. 3) in accordance with the curve in Fig. 6a. From Fig. 7 the angle is found to be 78° therefore the internal resistors mounted on terminals #7, #10, and #13, should be adjusted to 600 ohms.

The distance expressed in ohms impedance between the center of the modified impedance circle and the intersection of the "R" and "X" axis is a separate adjustment that is made on the auxiliary box. This distance, expressed in ohms impedance, should be measured from Fig. 7 and the auxiliary box set in accordance using the formula:

$$Z_R + A = \frac{Z_D R_c}{R K V}$$

$$Z_R + A = \frac{32 \times 600/5}{1000/1 \times 1.04} = 3.69 \text{ ohms}$$

ZR should be set on 3.7 ohms

A should be set on 0 ohm

The setting for the second and third impedance element is obtained in the same manner as the preceding example for the first impedance element.

### HZM Carrier Setting of Z3

When the type HZM relay is used with carrier, the third zone element must operate in a reverse direction from Z1 and Z2 whenever the modified distance characteristic is used. This is done to assure proper carrier blocking for external faults in the adjacent line section with a setting of Z3 which will not pick up on load or surge ohms.

The method of arriving at the proper setting is shown in Fig. 5 which also shows the normal settings of Z1, Z2, and Z3 when used without carrier. When the HZM relay is used with carrier, the ohmic reach of Z3 at station A in



the direction away from line AB should be greater than the reach of Z2 (from station B) past the local station bus (at A). Thus any fault in the zone Ab which picks up Z2 at B will also pick up Z3 at station A to block tripping at B. The zone ab is for a safety factor to insure that carrier will always be started at A before carrier tripping can be set up at B. For this service, Z3 should be set to reach out of the line 50% farther than the reach of Z2 (at B) past the station A Bus. In Fig. 5, this means Aa should be 150% of Ab. The reach of Z3 into the line section AB as shown is not critical.

The dotted connection between CS-1 contact and secondary of timer current transformer (Fig. 2) indicates the internal connection changes necessary when Z3 is used with a reversed characteristic. The timer is started by either the second or third element and is directionally controlled. Dual control of the timer is required when the third zone is used with a modified characteristic.

When the type HZM relay with the third zone element operating in a reverse direction is used, it is necessary that the polarity of the transformers in the auxiliary unit whose output is supply to the third zone impedance element be reversed. Normally, if the type HZM relays are specified for operation with carrier, this polarity reversal of the third zone modifying transformers will be made at the factory. If any doubt exists as to polarity, a check may be made as specified under "Adjustments and Maintenance, Calibrations of Impedance Elements". If it is desired, at any time, to reverse the polarity of the third zone modifying transformers, it is only necessary to reverse the two leads to Z<sub>R</sub> center taps of Z3 inside the auxiliary unit.

The time delay on the synchronous timer is set to coordinate with the relays backed up by the second and third impedance element. The setting is made by loosening the screws which clamp the contact assembly and moving the complete assembly to the desired position as indicated by the scale.

On lines where taps or parallel feeders supply fault power to the adjacent sections the apparent impedance to the relay backing up the adjacent section is greater than the actual impedance. The reason for this is that the relay does not measure the additional fault current supplied by the other feeders, but at the same time, this current does increase the voltage drop from the fault to the relay. This increases the apparent impedance to the adjacent section by the ratio of the total current to the relay current. The effect on the relay impedance elements is to back up the balance point of the second and third impedance elements. In order to extend the range of back-up protection under these conditions, the second elements can be set for a balance point farther than 150% normally recommended, provided it is made to time select with the adjacent section relay second element. Similarly, the third element can be set farther than normal if it is made to select with the second and third elements of the adjacent relay which it overlaps.

## INSTALLATION

The relays should be mounted on switchboard panels or their equivalent in a location free from dirt, moisture, excessive vibration and heat. Mount the relay vertically by means of the two mounting studs for the standard cases and the type FT projection case or by means of the four mounting holes on the flange for the semi-flush type FT case. Either of the studs or the mounting screws may be utilized for grounding the relay. The electrical connections may be made direct to the terminals by means of screws for steel panel mounting or to terminal studs furnished with the relay for ebony-asbestos or slate panel mounting. The terminal studs may be easily removed or inserted by locking two nuts on the studs and then turning the proper nut with a wrench.

## CONNECTIONS

### Impedance Elements

The impedance to the balance point is measured from the point where the potential transformers are connected to the protected

## TYPE HZM RELAY

line. For protecting transmission lines, the relays should receive potential from potential transformers connected directly to the line at the point from which the impedance is to be measured.

In some applications a power transformer bank forms part of the transmission line, and potential transformers are available only on the bus side of the bank. In this case the relays may be set thru the bank to protect the line only if the bank impedance is not too large as compared with the line impedance. If the bank impedance is too large in comparison with the line impedance, the 70 or 80% setting of the first element may cover only a very small percentage of the transmission line or in some cases not cover any of the line section. For the same reason the second and third elements will offer considerably less back-up protection over the adjacent lines. In order to use the potential transformers on the bus side of the bank under this condition, Type KX compensators are used and the impedance measured from the line side of the bank to the balance points. The type KX compensators operate from the current transformers and provide voltage compensation equivalent to the drop in the power bank.

The above discussion assumes that power is fed thru the bank to faults on the line. Where a power transformer connects to a high tension transmission line and does not supply power to the line fault, low-tension potential transformers may be used without compensation. Then, the impedance to the balance point is measured from the point where the power bank connects to the protected line.

The conventional star connection of current transformers is not satisfactory where accurate distance relay protection is desired. With this connection the balance points of the impedance elements shift about 15% depending upon whether a phase-to-phase, a three phase, or a double-line-to-ground fault is involved. That is, if the balance point were adjusted at 80% for a three phase fault, then for a double-line-to-ground fault, the shift may be more or less than plus or minus 15% of the 80% setting, depending upon the ratio of the zero

sequence impedance to the negative sequence impedance of the system from the source of power to the fault. This error can be entirely eliminated by making use of the vector difference between the line current; i.e., delta currents, for actuating the relay.

The most common method is to connect the main current transformer in star and use a set of auxiliary 5/5 ratio transformers to supply delta currents to the impedance element as shown in Figure 8.

The delta voltages used on the impedance elements of the relays should be in phase with the delta current, at unity power factor.

### Directional Element

The magnetic design of the element is such that maximum torque occurs when the current leads the voltage by 35 to 40 degrees. Thus, the directional element coils should be connected to receive current that leads the voltage by 90 degrees when the line power factor is 100 percent. This will result in operation at approximately the maximum torque angle for transmission line faults.

### Trip Circuit

The contactor switch operates on a minimum of 1.0 ampere, but the trip circuit should draw at least 4 or 5 amperes in order to reduce the time of the operation of the switch to a minimum and provide more positive operation. If the type HZM relay is used to trip an auxiliary multi-contact relay, provision should be made for loading down the trip circuit with a resistor in parallel with the operating coils of the auxiliary relay. Also, since the total trip circuit resistance in the relay is approximately 1.0 ohm, care must be taken to see that the breaker trip coil will receive enough current when low voltage control is used.

The main contact on the impedance elements and directional element will safely close 30 amperes at 250 volt d-c., and the switch contacts will safely carry this current long enough to trip a breaker.

## ADJUSTMENTS AND MAINTENANCE

The proper adjustments to insure correct operation of this relay have been made at the

factory and should not be disturbed after receipt by the customer. If the adjustments have been changed, the relay taken apart for repairs, or if it is desired to check the adjustments at regular maintenance periods, the instructions below should be followed.

All contacts should be periodically cleaned with a fine file S#1002110 file is recommended for this purpose. The use of abrasive material for cleaning contacts is not recommended, because of the danger of embedding small particles in the face of the soft silver and thus impairing the contacts.

#### Impedance Elements

The voltage circuit on the impedance elements is designed to have a comparatively flat phase angle curve. This is accomplished by energizing the two coils with currents that are essentially equal and 90° out of phase. The gaps as shown in Figure 1 are nominal dimensions which yield equal restraints from the two coils. The actual gaps on any particular relay may vary a few thousandths from these values.

If the voltage circuits have been disassembled, the gaps referred to in Figure 1 provide a nominal starting point for calibration. This is accomplished as follows:

1. Adjust the stop screw on the rear of the beam to give a clearance of .020 inch between the beam and the voltage iron circuit. With the beam in the reset position, i.e., with the stop screw against the stop, adjust the vertical gap for .010 inch between the adjustable iron and the beam. Care should be taken in this adjustment to keep the gap the same on both sides. Also, with the beam in the same position, adjust the gap between the front end of the beam and the stop in the upper core screw to .020 inch.

Further adjustment in the gaps may be necessary to obtain a flat phase angle curve.

The first and second impedance element beams should be balanced as follows. Connect the relay with polarities as shown in the test diagram, Figure 9. Set the auxiliary box tap  $Z_R$  and A on zero and  $\emptyset$  on any setting. With any tap and scale setting, check the impedance

measured by the relay with 60 volts potential restraint. Apply 10 volts restraint and adjust the balance weight on the beam until the beam just trips with 1/6 of the current required to trip with 60 volts restraint. The current should be suddenly applied.

The third impedance element beam should be balanced by adjusting the balance weight so that in the de-energized condition, the beam will reset, thus leaving its contact open. Do not introduce excessive resetting torque, but only enough to reset the element.

The stationary contact should be adjusted for a .020 inch gap when the beam is in the reset position. When the beam is in the operated position there should be a .015 inch deflection of the moving contact. The spring that carries the moving contact should lie flat on the Micarta arm with no initial tension on the contact. The flexible pigtail should be at least 3/32 inch from the end of the stationary contact.

#### Directional Element

The upper bearing screw should be screwed down until there is only three to four thousandths of an inch clearance between it and the shaft, and then securely locked in position with the lock nut. This adjustment can be made best by carefully screwing down the top bearing screw until the double loop fails to turn freely and then backing up 1/8 of a turn. Great care must be taken in making this adjustment to prevent damage to the bearings.

The front contact spring should be positioned in the center of the .020 inch slot of the aluminum guard by means of the small adjusting screw located on the nut plate that holds the spring on the moving element. The travel of the moving contact is limited by the stationary contacts mounted on the molded cover. The contact gap should be adjusted as follows: With the moving contact centered between the studs, close the contact gaps by advancing the two front stationary contacts. Then back-off the right-hand stationary contact .035 inch and lock both contacts in place. The complete moving element is limited in travel by two stop screws, located on the bottom of the element and readily accessible from the front. These should be adjusted so that the moving contact just touches the stationary contacts

## TYPE HZM RELAY

respectively when energized in the opening and closing directions with 120 volts and 5.0 amperes at maximum torque. The right-hand stationary contact should be turned 1/6th of a turn to obtain .005 inch contact follow. Too much follow should be avoided to insure proper coordination. The back stationary contact stops should be adjusted to just touch the moving contact when energized as above. The spring should be adjusted so that the contacts close with 1.0 volt and 5 amperes at maximum torque.

A small lever arm extending to the front on the bottom of the element controls a magnetic bias in the center of the electromagnet. This should be adjusted so that the element will operate with 30 amperes and 0.1 to 0.4 volt at the maximum torque angle. After this adjustment, short the voltage coils and check to insure that the contacts do not close on 60 amperes momentarily applied.

### Contact Switch (Seal-In Switch) CS

Adjust the stationary core of the switch for clearance between the stationary core and the moving core of 1/32 inch when the switch is picked up. This can be done by disconnecting the switch, turning it up-side-down and screwing up the core screw until the contact just separates. Then back off the core screws approximately one turn and lock in place. This prevents the moving core from striking and sticking to the stationary core because of residual magnetism. Adjust the contact clearance for 3/32 inch by means of the two small nuts on either side of the Micarta disc. The switch should pick up at 1.0 amperes d-c. Test for sticking after 30 amperes d-c are passed thru the coil.

### Contact Switch CSA

The adjustments are the same as for the seal-in contactor switch "CS" except that the contact separation should be 1/32 inch. For 125 volt d-c relays apply 60 volts d-c to Nos. 9 and 10 terminals. Similarly for 250 volt d-c relays apply 120 volts d-c to Nos. 9 and 10 terminals. See that the switch picks up and closes its contacts positively when the contact of the third impedance element is made. The switch coil is intermittently

rated, and therefore care should be exercised so as not to overheat the coil.

### Contact Switches CS-1 and CS-2

The adjustments are the same as for the seal-in contactor switch CS except that the contact separation should be 1/32 inch. For 125 volt d-c relays apply 60 volts d-c positive to Nos. 2 and 10 terminals and negative to Nos. 7 and 9 terminals. Similarly for 250 volt d-c relays use a test voltage of 120 volts d-c. See that switch CS-1 picks up and closes its contact positively when the directional and Z-2 impedance element contacts are made. See that CS-2 picks up and closes its contacts when the directional element and Z-3 impedance element contacts are made. These switch coils are intermittently rated, and therefore care should be exercised so as not to overheat the coils.

### Operating Indicator

Adjust the indicator to operate at 1.0 ampere d-c gradually applied. Test for sticking after 30 amperes d-c are passed thru the coil.

### Synchronous Timer

When testing the synchronous timer, complete the transformer circuit by a jumper around the contacts on the contactor switch CS-1 or CS-2 rather than operating the switch on d-c. Test the motor with 3.5 amperes thru the current circuit of the relay. This is the minimum current at which it will run in synchronism.

### Timing Tests

Accurate time tests on the instantaneous and directional elements can only be taken with the aid of an oscillograph or high speed timer. The cycle counter is used only to time the synchronous timer and in timing the high speed elements near their balance point where the time may be several cycles.

The d-c trip circuit should be loaded with a resistor to draw approximately 5 amperes and an auxiliary relay should be used to operate the cycle counter if time tests are to be taken. There is a slight vibration of the beam and contacts to the pulsating pull on the current side of the instantaneous element. This vibration will prevent positive stopping

## TYPE HZM RELAY

of a cycle counter unless an auxiliary type MG relay is used. The loading resistor will cause the contactor switch to seal-in and simulates the actual service condition when a circuit breaker is to be tripped.

### Calibration of Impedance Elements

The auxiliary box has been calibrated at the factory and this calibration should not be disturbed except to adjust the internal resistor to obtain the correct phase angle ( $\phi$ ). If it is necessary to check the polarity of the third zone modifying transformers with respect to the first and second zone modifying transformers this may be done as follows: Set  $Z_R = 7.5$  ohms and  $A = 0$  on all taps. Pass 5.0 amperes in terminal #1 and out of terminal #2 of the auxiliary unit. With a high resistance voltmeter, at least 1000 ohms per volt measure voltage from terminal #7 to terminal #9. This voltage measured should be less than 25 volts if the transformer polarities are the same Repeat by passing current in terminal #2 and out terminal #3. Measure voltage across terminal #10 and terminal #12, across terminal #13 and terminal #15.

If the auxiliary box circle displacement setting is set on zero, that is  $Z_R = 0$  and  $A = 0$ , then the type HZM relay will have characteristic similar to the type HZ relay and may be calibrated in the same manner as follows. The current required to operate the impedance elements against any given voltage is obtained from the equation:

$$TSI = 10 E$$

where TSI is the operating force which is equal to T, the current tap setting times S, the setting of the calibrated core screw, times I, the current applied to the relay and 10E is the restraining force which is equal to E, the voltage applied to the relay multiplied by the constant ten. Thus, if the setting is T, 20.8, S = 1.8 and the voltage is 60 volts, then the current required at 60° lagging is

$$I = \frac{10 E}{TS} = \frac{10 \times 60}{20.8 \times 1.8} = 16 \text{ amperes}$$

When calibrating the impedance elements it is best to do so at a phase angle equal to the

phase angle between current and voltage on the transmission line to be protected by the relay.

**CAUTION** Make certain that the stops on the rear and front of each beam are absolutely clean otherwise the impedance at which the beam trips may be affected, particularly at low voltages. The stop can be easily cleaned by drawing a piece of clean white paper between the beam and the stop while the beam is firmly pressed down.

Also, when checking the impedance elements, at low voltage, observe the tripping of the beam instead of an indication in the trip circuit. This will prevent an error in the contact adjustment which might otherwise affect the beam calibration.

## RENEWAL PARTS

Repair work can be done most satisfactorily at the factory. However, interchangeable parts can be furnished to the customers who are equipped for doing repair work. When ordering parts, always give the complete nameplate data.

## ENERGY REQUIREMENTS

The 60 cycle burden of the various circuits of this relay are as follows:

### POTENTIAL CIRCUIT

| <u>Circuit</u>   | <u>Volts</u> | <u>V.A.</u> | <u>P.F. Angle</u> |
|--|--------------|-------------|-------------------|
| All impedance elements including external auxiliary box. |              |             |                   |
| *Displacement angle of 90°                               | 120          | 7.9         | 46° lag           |
| *Displacement angle of 60°                               | 120          | 7.5         | 30° lag           |
| *Directional Element                                     | 120          | 6.0         | 55° lag           |

### CURRENT CIRCUITS

All impedance elements including external auxiliary box and timer.

| <u>Taps</u>                            | <u>Amps.</u> | <u>V.A.</u> | <u>P.F. Angle</u> |
|--|--------------|-------------|-------------------|
| T=45, S=1.8, $Z_R = 7.5$ ,<br>A=0.0    | 8.66         | 38.0        | 52° lag           |
| T=13.5, S= 1.4, $Z_R = 0.0$ ,<br>A=1.1 | 8.66         | 20.0        | 55° lag           |

### DIRECTIONAL ELEMENT

|       |   |     |         |
|-------|---|-----|---------|
| ----- | 5 | 2.0 | 50° lag |
|-------|---|-----|---------|

# TYPE HZM RELAY

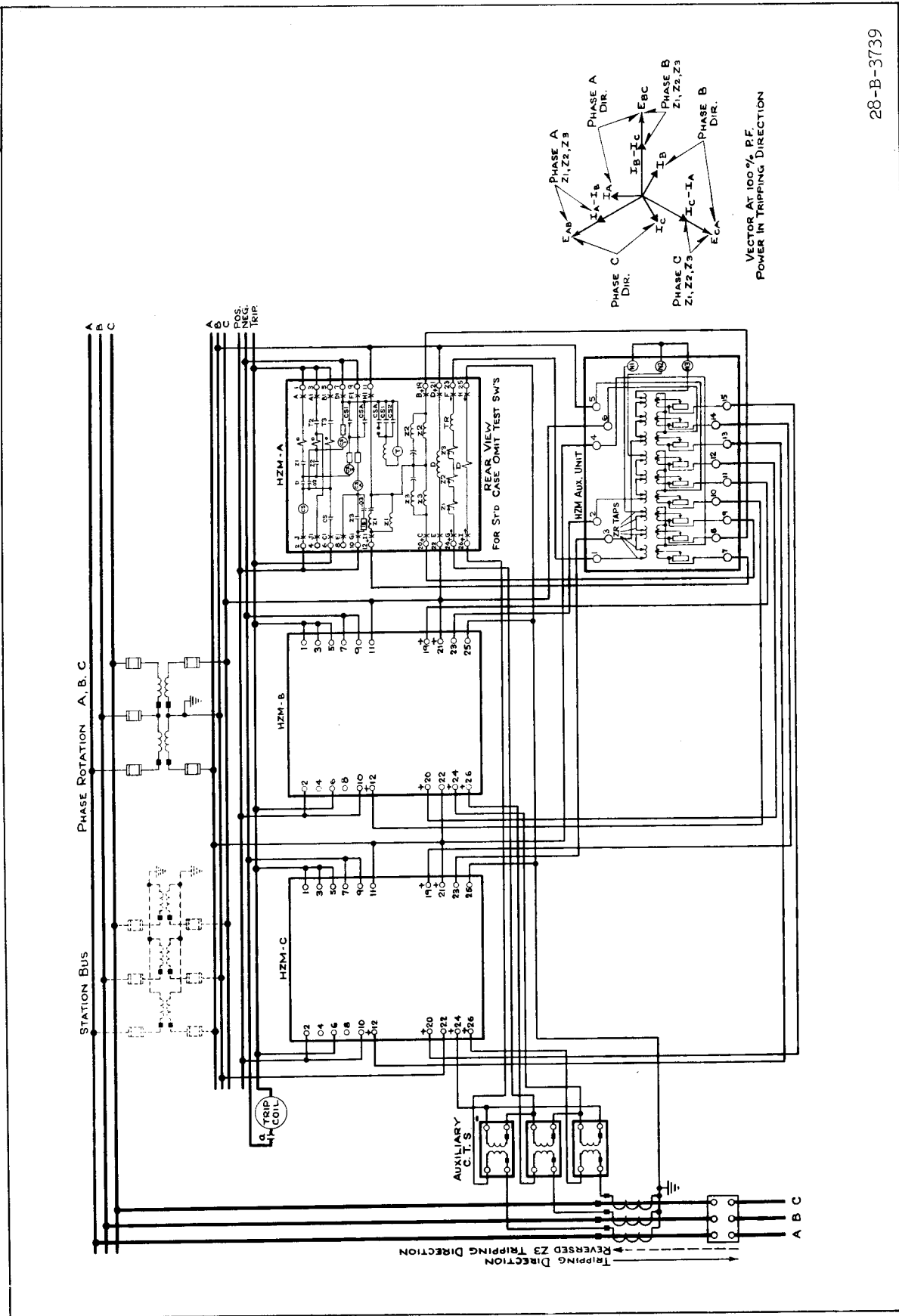

\* Fig. 8 - External Connections for Phase Protection of a Transmission Line Using the Type HZM Relay.

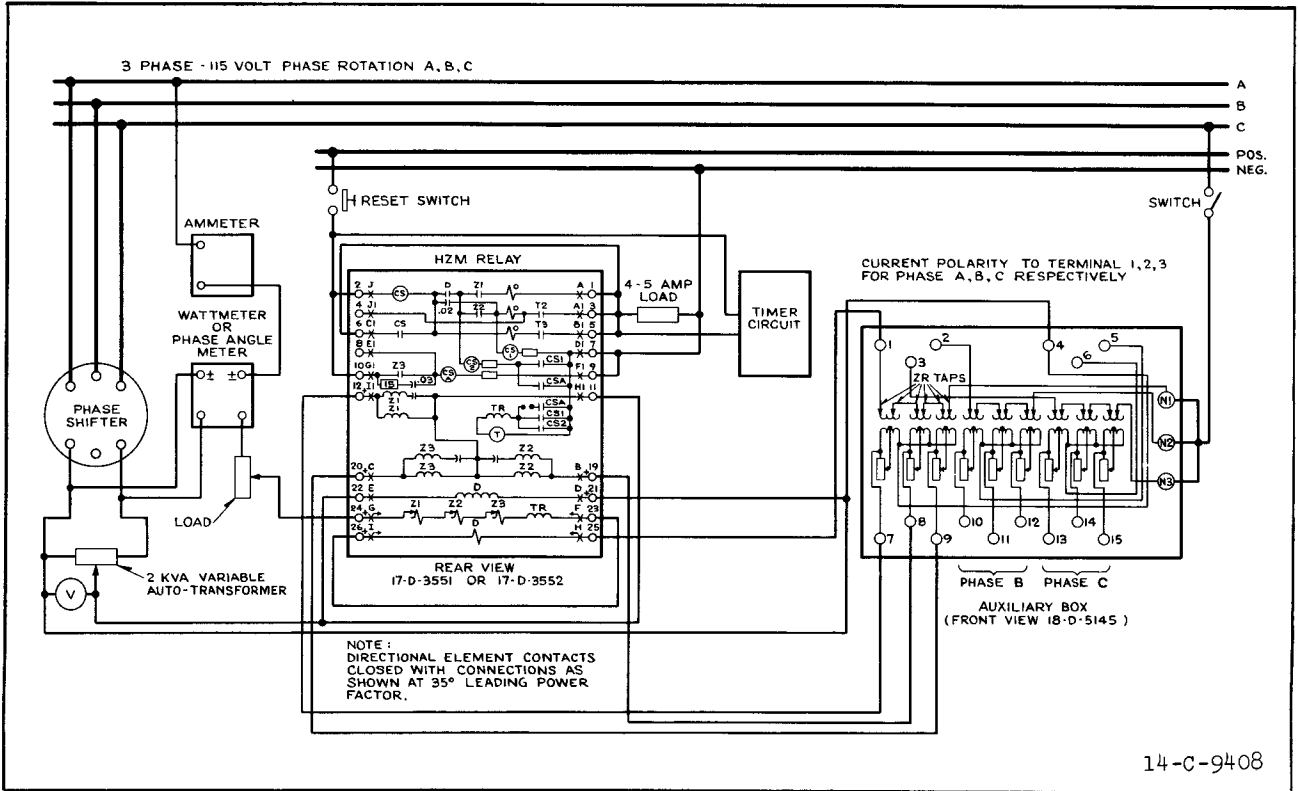

Fig. 9— Diagram of Test Connections for the Type HZM Relay.

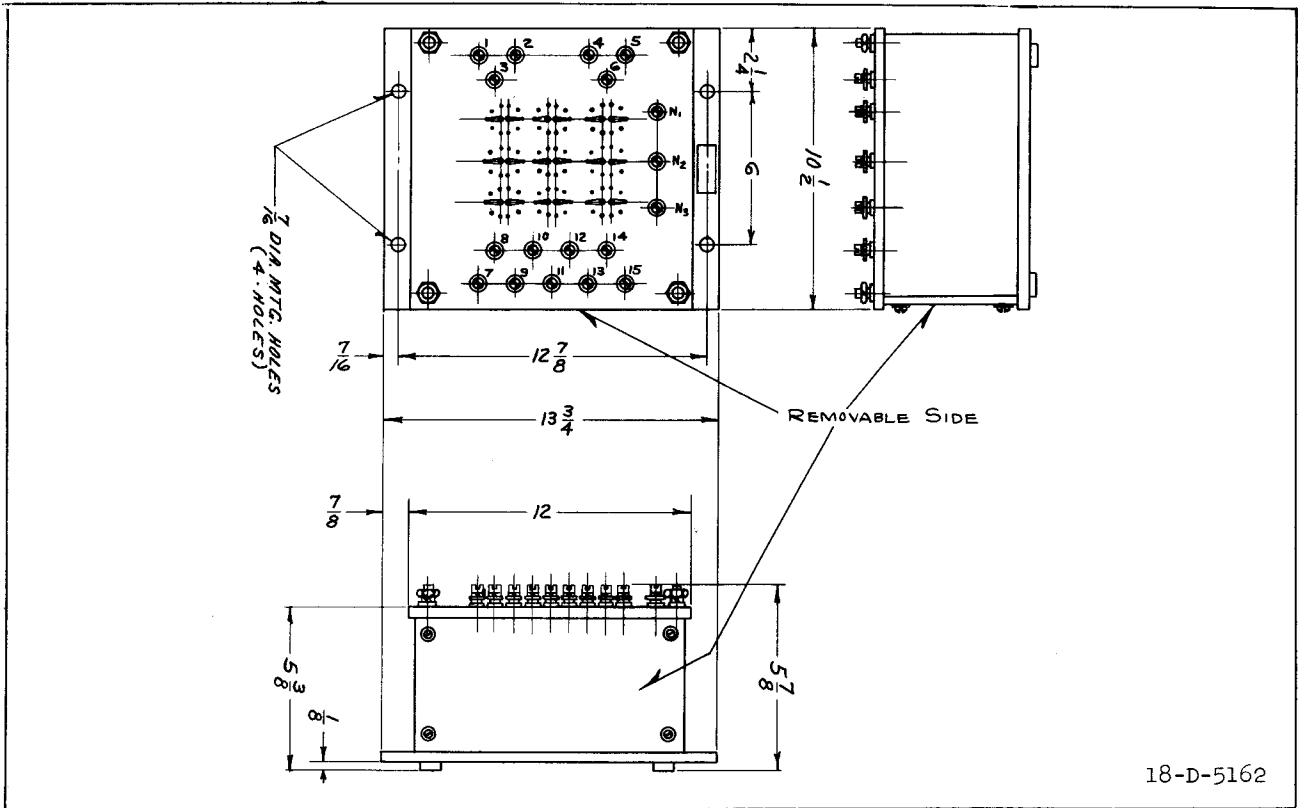

Fig. 10— Outline and Drilling Plan for the Nine Element Auxiliary Unit. For Reference Only.

# TYPE HZM RELAY

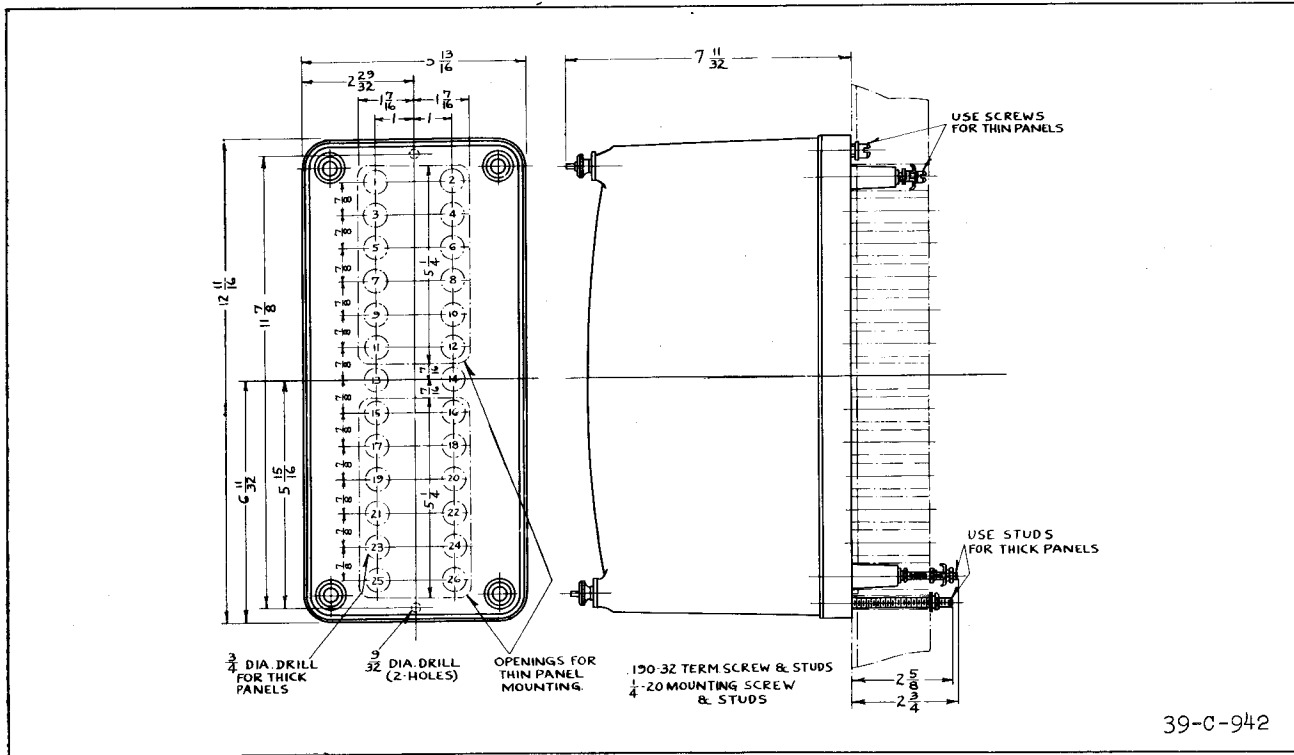

Fig. 11- Outline and Drilling Plan for the Standard Projection Case. See the Internal Schematics for the Terminals Supplied. For Reference Only.

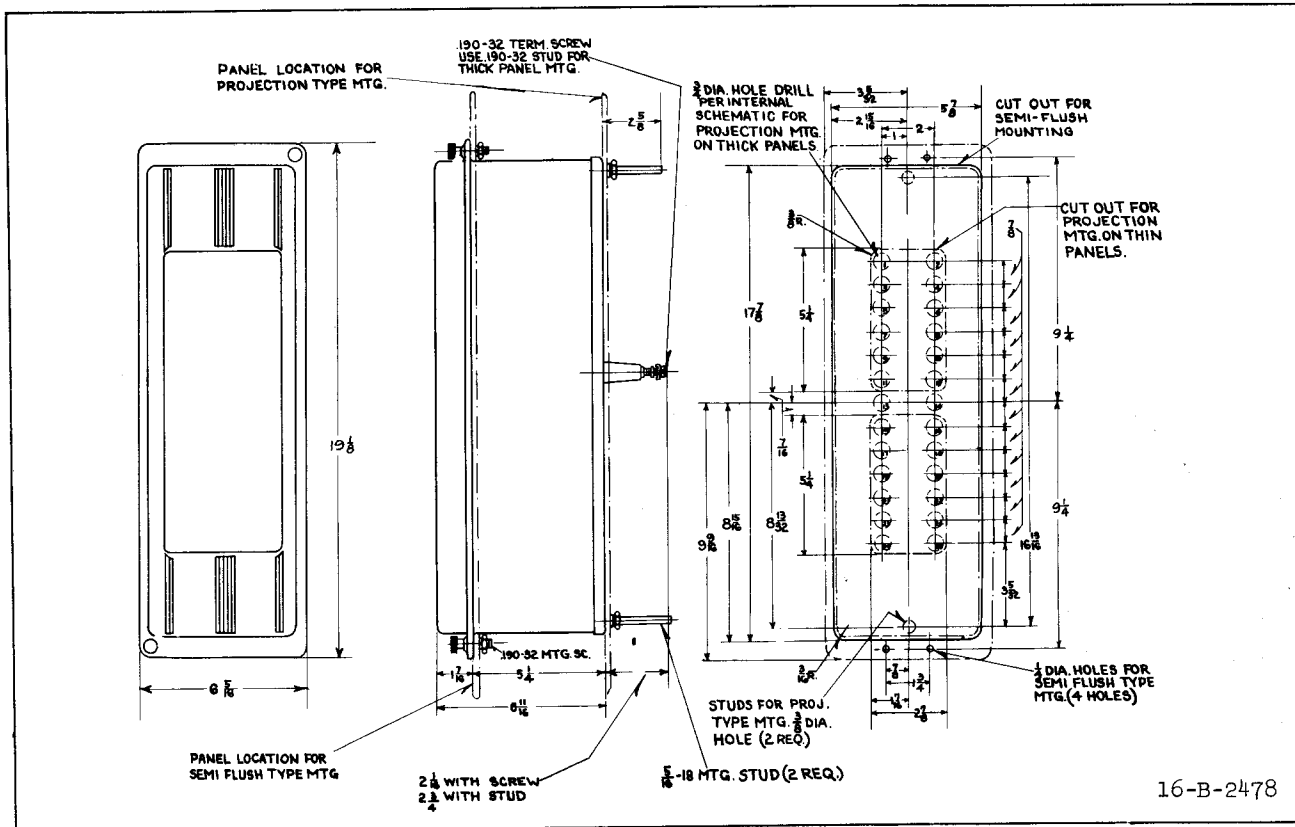

Fig. 12- Outline and Drilling Plan for the M20 Projection or Semi-Flush Type FT Case. See the Internal Schematic for The Terminals Supplied For Reference Only.