



ADDENDUM TO WESTINGHOUSE I.L. 41-110  
INSTALLATION • OPERATION • MAINTENANCE  
**I N S T R U C T I O N S**

**TYPE SCO SOLID STATE SINGLE PHASE  
OVERCURRENT RELAY**

This sheet notes changes which should be made in instruction leaflet I.L. 41-110 dated March 1977.

1. On page 28, first column. The first paragraph should have a sentence added to read as follows:

The instantaneous unit is responsive to total current including dc component, and an allowance must be made in the setting to avoid overtripping. Normally a setting of 1.25 times the maximum symmetrical current for which the unit should not trip will provide an adequate margin to prevent undesired tripping due to dc offset. Maximum setting should not be greater than 35 times to insure optimum coordination with the time delay unit.

*All possible contingencies which may arise during installation, operation, or maintenance, and all details and variations of this equipment do not purport to be covered by these instructions. If further information is desired by purchaser regarding his particular installation, operation or maintenance of his equipment, the local Westinghouse Electric Corporation representative should be contacted.*

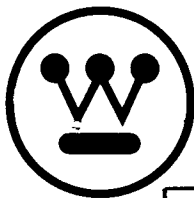
**INSTALLATION • OPERATION • MAINTENANCE  
I N S T R U C T I O N S****TYPE SCO SOLID STATE SINGLE PHASE  
OVERCURRENT RELAY**

**CAUTION:** It is recommended that the user become acquainted with the information in this instruction leaflet before energizing the equipment. Failure to observe this precaution may result in damage to the equipment.

**APPLICATION**

The SCO relay is a single phase solid state non-

directional time over-current device. It is used to sense current level above the setting and normally is used to trip a circuit breaker to clear faults. A wide range of characteristics permit applications involving coordination with fuses, reclosers, cold load pickup, motor starting, or essentially fixed time applications.

The following describes typical applications of the SCO Relay:

<b>RELAY TYPE</b>	<b>CURVE MODULE</b>	<b>TIME CURVE</b>	<b>TYPICAL APPLICATIONS</b>
SCO-2	A02	Short	1) Differential protection where saturation of current transformers is not expected, or where delayed tripping is permissible. 2) Overcurrent protection, phase or ground, where coordination with downstream devices is not involved and 2 to 60 cycle tripping is allowable.
SCO-5	A05	Long	Motor locked rotor protection where allowable locked rotor time is approximately between 10 and 70 seconds.
SCO-6	A06	Definite	Overcurrent protection where coordination with downstream devices is not involved and SCO-2 is too fast. The operating time of this relay does not vary greatly as current level varies.
SCO-7	A07	Moderately Inverse	1) Overcurrent protection where coordination with other devices is required, and generation varies. 2) Backup protection for relays on other circuits.
SCO-8	A08	Inverse	
SCO-9	A09	Very Inverse	
SCO-11	A11	Extremely Inverse	1) Motor protection where allowable locked rotor time is less than 10 sec. 2) Overcurrent protection where coordination with fuses and reclosers is involved, or where cold load pickup or transformer inrush are factors.

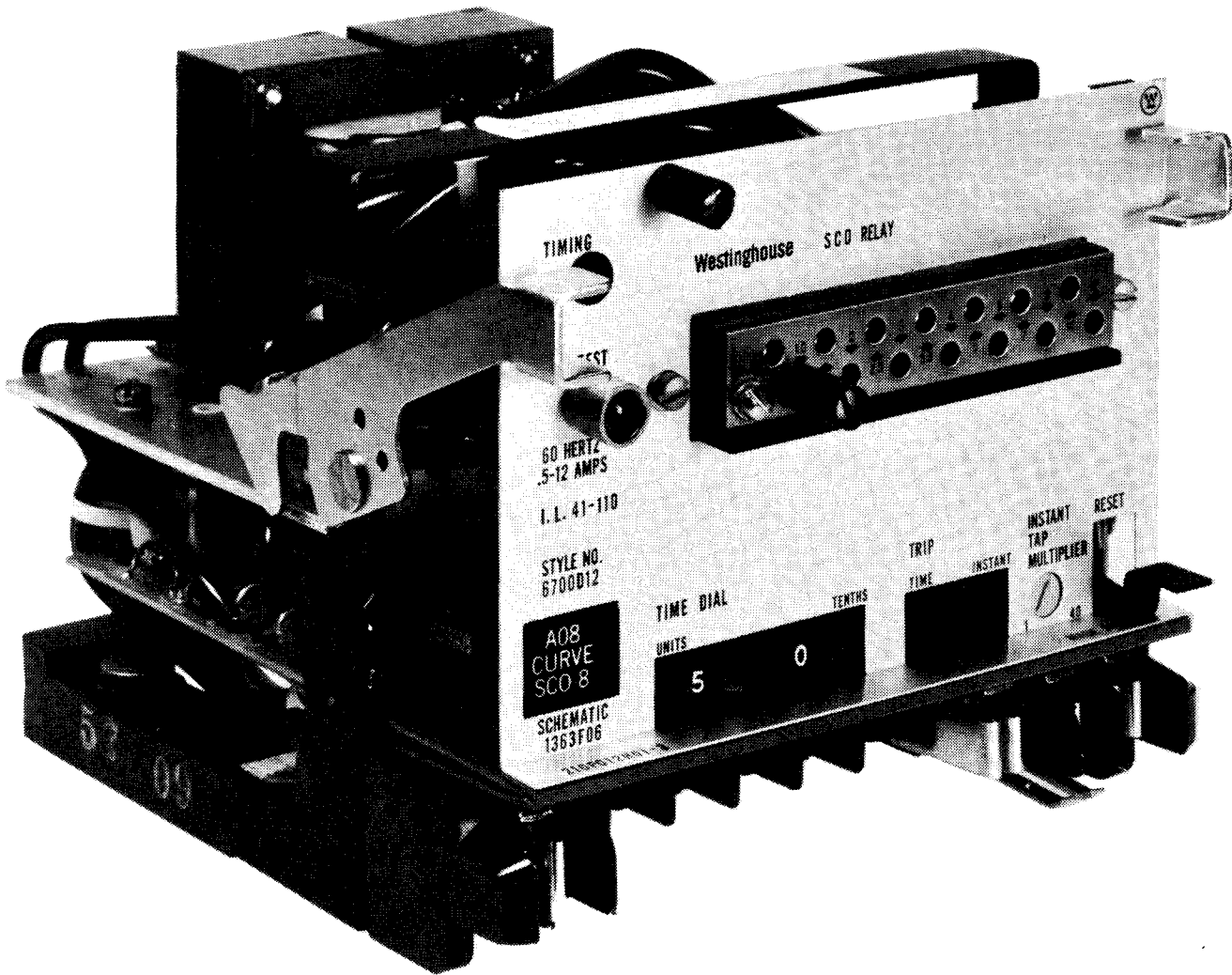

Fig. 1. Type SCO Relay—Front Left Side View

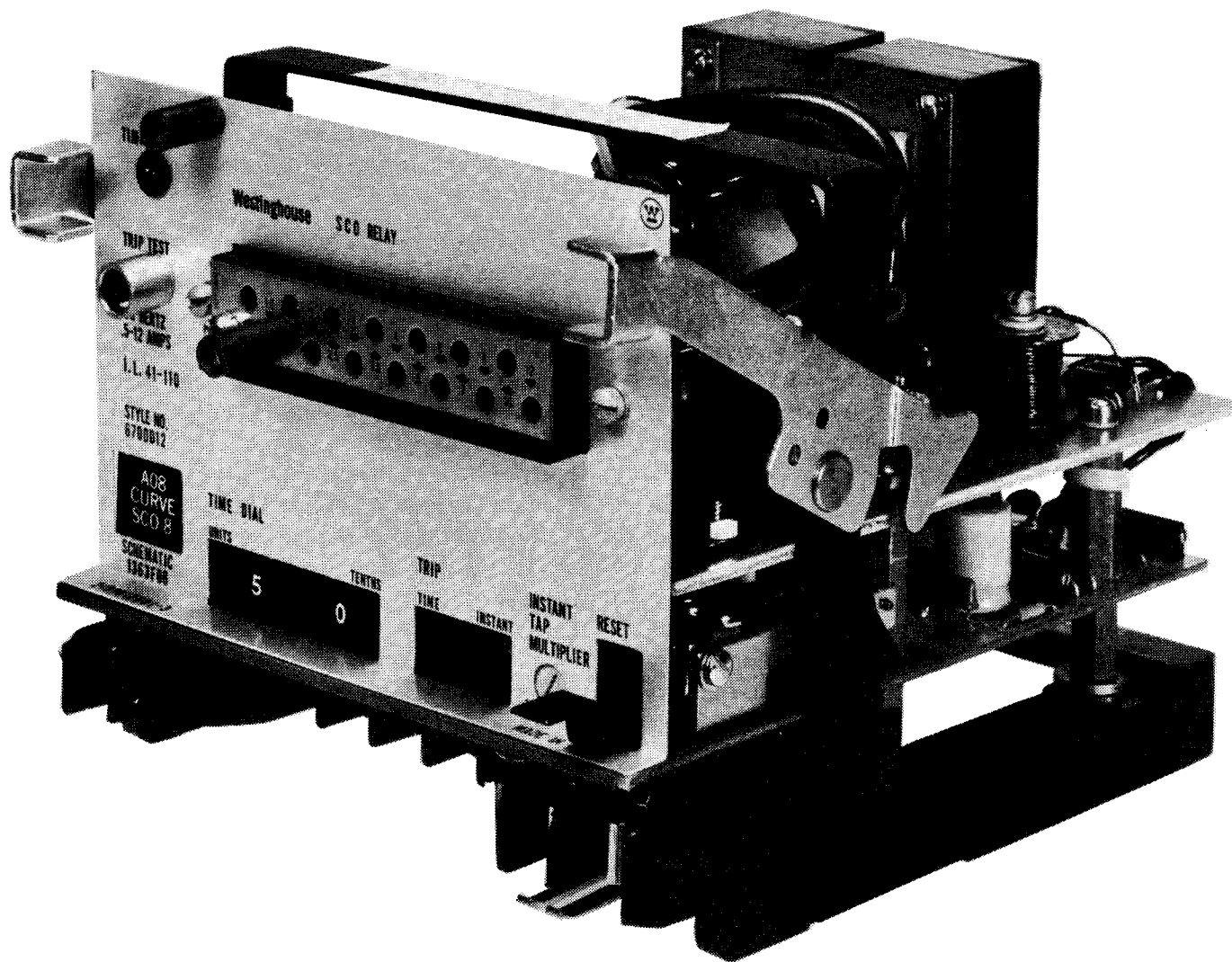

Fig. 2. Type SCO Relay—Front Right Side View

## TYPE SCO SINGLE PHASE RELAY

---

Two phase units and one ground unit are suitable for detecting all fault combinations. (The three-phase SCO may be used in this way or it may be used to monitor the three individual phase currents. A separate ground relay is normally used where this latter arrangement is applied).

The SCO relay is equipped with an instantaneous trip feature to provide high speed tripping for high current faults. Where instantaneous trip lockout by reclosing relay is desired, the SCO-T (with separate trip outputs) must be used (see I.L 41-111, SCO-T relay).

Instantaneous trip units can be applied effectively where wide variations in fault currents occur for different fault locations, but have limited applications where wide variations in fault currents occur for a fixed fault location. It responds to total current and must be set to include the effect of dc current and to override the conditions that should be ignored such as transformer inrush, motor locked rotor, and faults outside of the desired trip zone.

A single thyristor trip output is included and separate indication is provided of instantaneous and time delay trip outputs. No indication occurs unless there is current flow in the trip circuit. Indicator reset is accomplished manually.

The relay is self contained in that the power supply for the solid state logic is derived from the

current transformer. There is no continuous drain on the tripping battery.

See SETTINGS Section for further application data.

### CONSTRUCTION

The SCO relay is a static relay consisting of 2 printed circuit modules, a time curve plug-in module, and a front panel assembly, packaged in a FT-11 case. For detailed information on the flexitest case, refer to I.L 41-076.

The photographs in Figures 1 and 2 show the front and rear view of the SCO relay removed from the case.

All of the circuitry suitable for mounting on printed circuit boards is contained on the two modules horizontally mounted on posts behind the front panel. The top module contains the transformer and "front-end" circuitry for the SCO while the bottom module contains the power supply, information sensing, curve shaping, tripping, and indication circuitry, as well as the plug-in curve module. Terminals for current input and trip output are located on the rear of the case, and all inputs and outputs pass through the FT switchjaws on the lower front part of the relay, below the front panel. The front panel, in addition to showing all pertinent style and setting information, has the minimum pickup indicator and the trip test switch located on the upper left-hand side.

**TYPE SCO SINGLE PHASE RELAY**

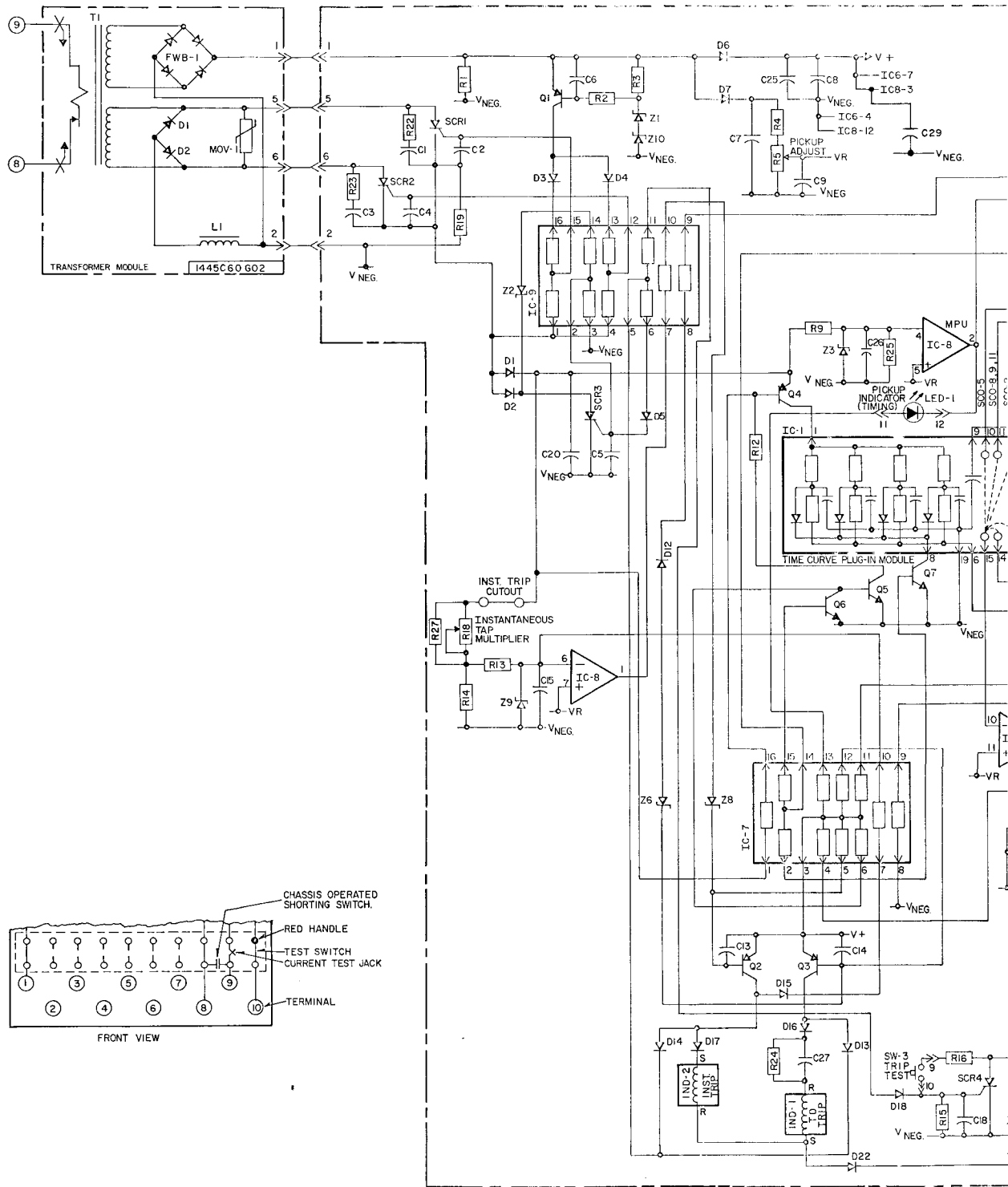
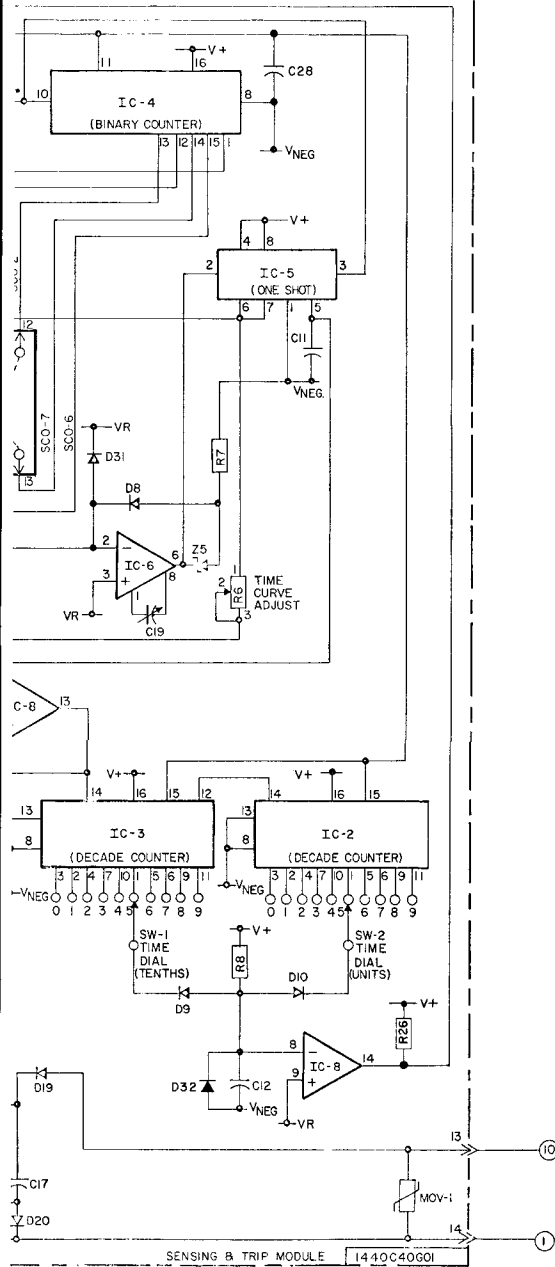

Fig. 3. SCO Interna



MODULE 1440C40G01		
CAPACITOR	DESCRIPTION	STYLE NO.
C1-3	.05UF 500V	879A911H13
C2-4-5-12-18	1000.000PF 100V	3509A34H01
C5-11	.010UF 50V	3509A34H02
C7	22.000UF 16V	3509A32H01
C8	220.000UF 16V	3509A32H02
C9	470.000PF 1000V	879A911H10
C13-14	.100UF 50V	3509A34H03
C15	.100UF 50V	717899H07
C17	.02MFD 500V	762A680H01
C19	5.5-30 PF 50V	3516A79H01
C20	2.000UF 200V	3509A35H01
C25-29	.470UF 50V	762A680H04
C26	.470UF 35V	837A241H21
C27	2.200UF 35V	837A241H16
C28	.01 UF 500V	879A911H12

DIODE	DESCRIPTION	STYLE NO.
D1-5-18-22	1N4822	188A342H11
D2-19-20	1N5406	188A342H21
D3-4-6-7-13		
14-16-17	1N4818	188A342H06
D8-9-10-12		
-15-31-32	1N4148	836A928H06

INT. KCT	DESCRIPTION	STYLE NO.
IC2-3	4017AE	3494A01H15
IC4	4040AE	3494A01H14
IC5	SE555CV	774B956H01
IC6	LM301AN	775B061H01
IC8	MC3302P	775B062H01

POT.	DESCRIPTION	STYLE NO.
R5	50.0K .75W	880A826H06
R6	10.0K .75W	880A826H05
R18	500.0K .75W	3512A37H01

TRANSISTOR	DESCRIPTION	STYLE NO.
Q1-2-3	2N2907A	762A672H17
Q4	2N5401	3509A35H01
Q5	2N5551	3509A35H02
Q6-7	2N2222A	762A672H15

RESISTOR	DESCRIPTION	STYLE NO.
R1	3.0K 50W 2%	629A531H43
R2	1000.0 25W 5%	836A908H63
R3	150.0 50W 2%	629A531H12
R4-26	81.0K 50W 2%	629A531H13
R7	300.0K 25W 2%	836A909H73
R8-R9-R13	100.0K 50W 2%	629A531H80
R12	24.3K 50W 1%	862A377H38
R14	7.5K 50W 1%	862A376H85
R15	200.0 25W 5%	836A908H46
R16	3.0K 0.5W 5%	876A046H71
R19	50.0 5.0W 1%	763A130H57
R22-23	100.0 50W 2%	629A531H08
R24	1000.0 50W 1%	848A819H48
R25	1.0M 50W 1%	848A822H33
R27	931.0K 50W 1%	862A378H94

ZENER	DESCRIPTION	STYLE NO.
Z1-10	1N752A 5.6V	186A797H12
Z2	UZ8120 200.0V	837A699H16
Z9	1N959 8.2V	837A398H12
Z5	1N750A 4.7V	837A398H03
Z6-8-3	1N5235B 6.8V	826A288H07

CURVE MODULE	DESCRIPTION	STYLE NO.
IC1	SCO-2	1442C29G02
	SCO-5	" 5
	SCO-6	" 6
	SCO-7	" 7
	SCO-8	" 8
	SCO-9	" 9
	SCO-11	" 11

VARISTOR	DESCRIPTION	STYLE NO.
MOV-1	V250LA15A	3509A31H01

SILICON RECT	DESCRIPTION	STYLE NO.
SCR-1-2-3	S4003LS2	3509A50H01
SCR-4	S4010L	3509A50H02

STRIP SW	DESCRIPTION	STYLE NO.
SW-1-2	2A21601G	3509A52H01

RESISTOR NETWORK	DESCRIPTION	STYLE NO.
IC7	-	775B106H01
IC9	-	775B107H01

INDICATOR	DESCRIPTION	STYLE NO.
IND-1-2	-	3513A71G01

MODULE 1445C60G02		
VARIABLE	DESCRIPTION	STYLE NO.
MOV-1	ERZ-C10DK471	3509A31H02

TRANSFORMER	DESCRIPTION	STYLE NO.
T1	-	1440C18G04

RECTIFIER	DESCRIPTION	STYLE NO.
FWB-1	VM48	3511A9GH01

DIODE	DESCRIPTION	STYLE NO.
DI-2	1N4822	188A342H11

INDUCTOR	DESCRIPTION	STYLE NO.
LI	15.0UH	3516A48G01

MOUNTED ON FRONT PANEL		
LED	DESCRIPTION	STYLE NO.
LED-1	PICKUP INDICATOR	879A774H02

SWITCH	DESCRIPTION	STYLE NO.
SW-3	TEST TRIP SWITCH	3510A06H01

SUB. 5  
1363F06

TYPE SCO SINGLE PHASE RELAY

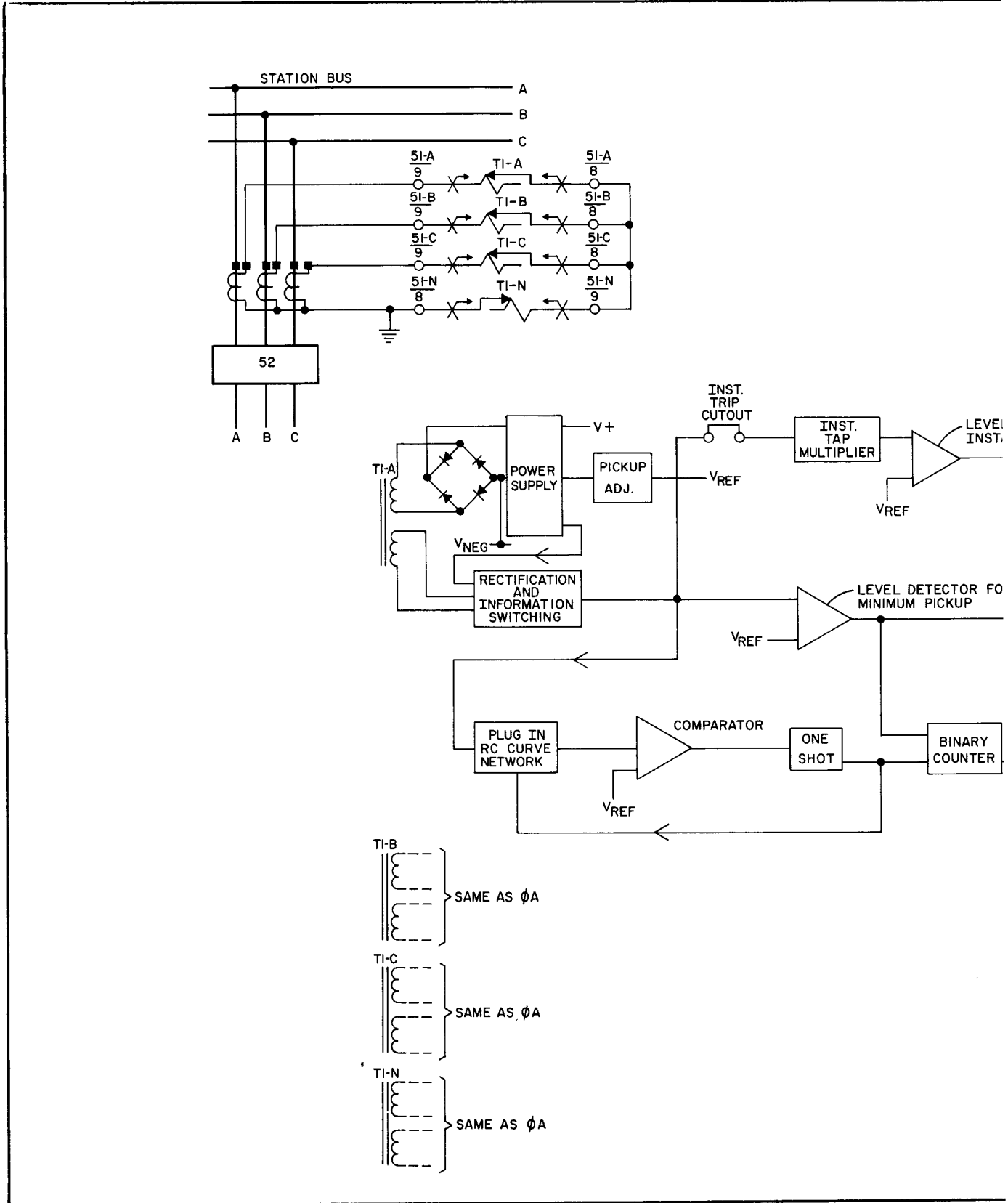
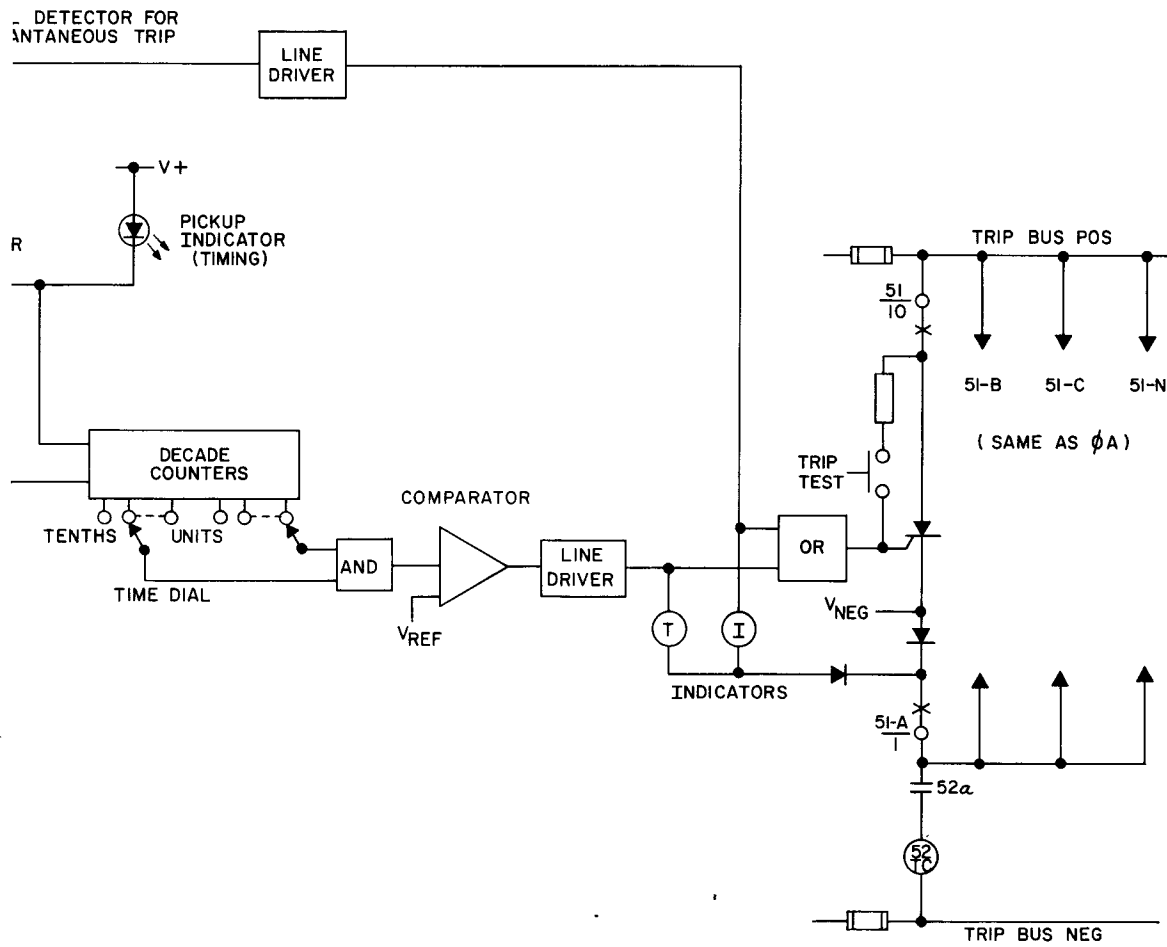

Fig. 4. SCC



DEVICE NUMBER CHART	
5I	OVERCURRENT RELAY TYPE SCO
5I-A	PHASE A SCO
5I-B	PHASE B SCO
5I-C	PHASE C SCO
5I-N	GROUND SCO
52	POWER CIRCUIT BREAKER
52a	BREAKER AUX.(CLOSED WHEN BKR. IS CLOSED)
52TC	BREAKER TRIP COIL



SUB. 2  
1451C14

## PRINTED CIRCUIT MODULES

Following is a description of the printed circuit modules used in the SCO relay. Refer to the internal schematic shown in Figure 3. This schematic contains a detailed scheme for understanding of the circuitry and a complete list and description of the components for renewal parts.

For those users not generally acquainted with circuit notation or with device symbols of those components used in the SCO drawings, it is recommended that a copy of Westinghouse instruction leaflet I.L. 41-000.1 entitled "Symbols for Solid State Protective Relaying" be consulted.

## TRANSFORMER MODULE

Component Location Figure 5.

The transformer module, mounted at the top of the relay, contains the current transformer for obtaining the line current information and also supplies the power to operate the electronic circuits. A tap block with 14 taps covering the range of 0.5-12 amperes, is contained at the front of the module and protrudes through the front panel. A full-wave-bridge for the power supply winding and two diodes for the information winding of the transformer are also mounted on this circuit module to minimize wiring between the two modules.

## SENSING & TRIP MODULE

Component location Figure 6.

The sensing and trip module is mounted at the bottom of the relay, beneath the transformer module. It contains the circuitry for power supply voltages  $V+$  and  $V_R$ , information sensing, curve shaping, tripping and indication. It also contains two decade thumb wheel switches for setting the time-dial, the potentiometer for setting the instantaneous trip, the instantaneous trip cut-out jumper, the reset lever assembly for resetting the time delay and instantaneous trip indicators, and the socket for the plug-in curve module. It also contains the two multi-turn trimpot calibration controls for setting minimum pickup and calibrating the curve.

## TIME CURVE MODULE

The time curve module is a 24 pin plug-in module containing the specific circuitry and components for each particular curve style. There are seven different curve module styles corresponding to the SCO-2, SCO-5, SCO-6, SCO-7, SCO-8, SCO-9 and SCO-11 curves. This module plugs into the 24 pin socket on the sensing-trip module and is visible to the front of the relay through a window in the front panel. There the front label on the module completes the last 3 digits of the style of the relay (printed on the front panel), and also shows which curve the relay is set for i.e. "SCO-2 curve". See Figure 1 front photograph and Figure 6 for exact location. For further information on time curve modules see Plug-in Curve Modules section in Renewal Parts of this instruction leaflet and also I.L. 41-110.2 instruction leaflet for Type SCO Time Curve Plug-in Modules.

## FRONT PANEL

The front panel, which is attached to the two tap block brackets on the transformer module, shows all pertinent style and setting information. It also has the minimum pick-up indicator and the trip test switch mounted on the upper left hand side. See Figure 1 for exact location.

## MINIMUM PICKUP INDICATOR TIMING

The minimum pickup indicator is mounted on the upper left-hand corner of the front panel. It consists of a light-emitting diode which is dimly lit at 99% tap value current and fully energized when current exceeds the minimum tap value. It is visible to the front of the relay which facilitates monitoring and testing. See Figure 1 for exact location.

## TRIP TEST SWITCH

The trip test switch is mounted on the upper left-hand side of the front panel. It consists of a push-to-test switch protected from accidental activation by a shield guard which requires a definite depression of the switch by some device that fits inside the guard, i.e. pencil, slender rod, etc. See Figure 1 for exact location.

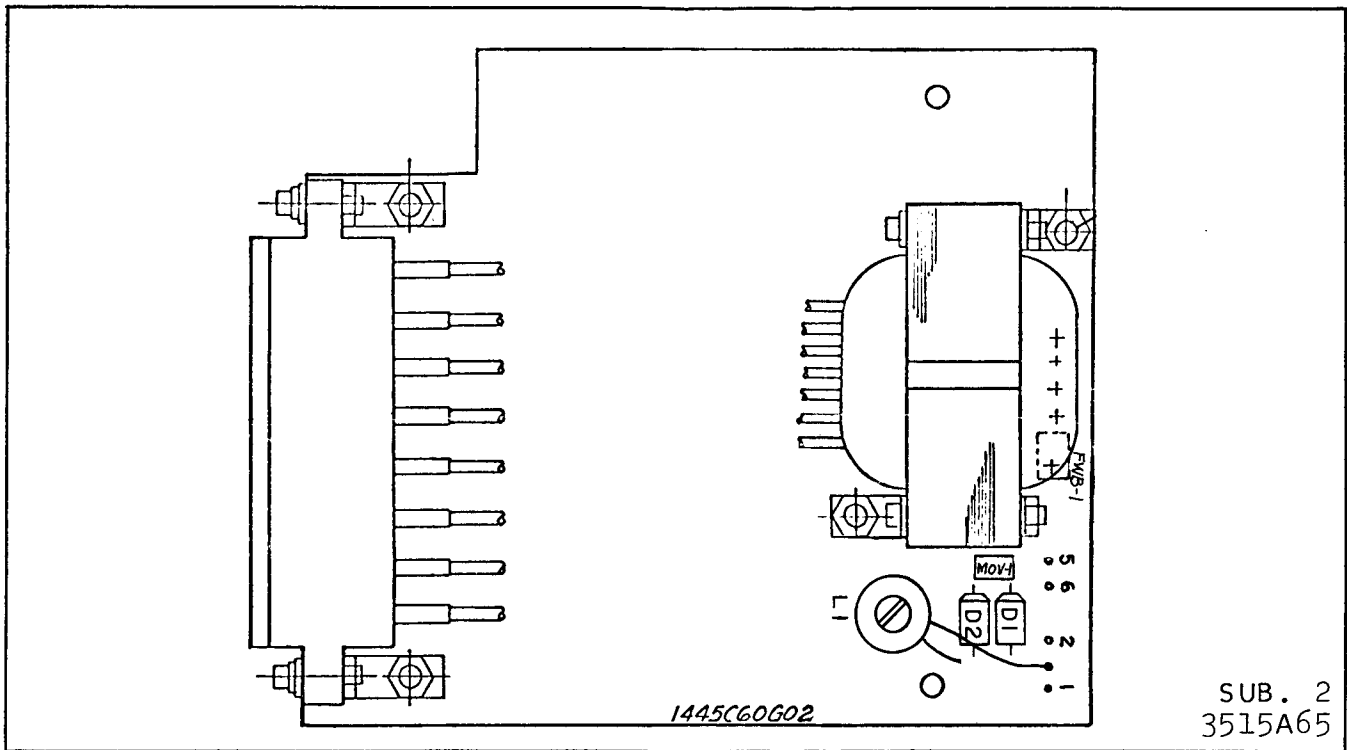

Fig. 5. Transformer Module Component Location Single Phase

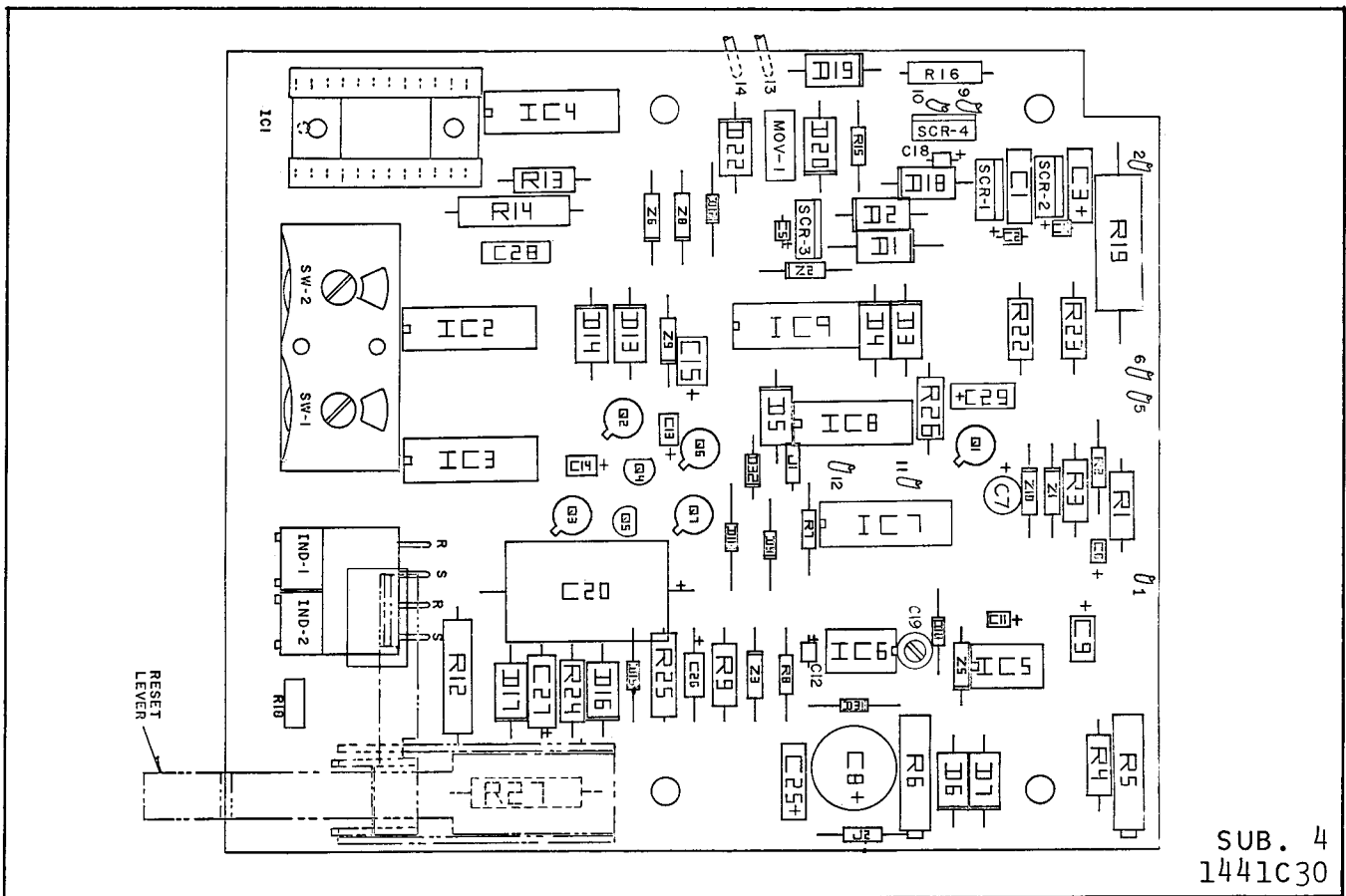

Fig. 6. Sensing-Trip Module Component Location Single Phase

## THEORY OF OPERATION

The basic operation of the SCO relay will be described with the aid of Figure 3 internal schematic 1363F06, and Figure 4 external scheme.

The SCO relay derives both its power and its sensing information from a single transformer. The type of transformer used is of the linear current transformer design consisting of a tapped primary winding and two secondary windings. The tapped primary winding allows 14 different pickup current settings from 0.5 to 12 amperes. One of the two secondary windings is a high current power supply winding (low number of turns) and the other one is a low current information winding (high number of turns). The circuit operation is based on the transformer ampere-turns balance principle between the primary and the secondary. Following each zero crossing of the line current, balancing of the primary ampere-turns is first achieved by the high current winding. During this time thyristors SCR-1 and SCR-2 are both off and the power supply regulator circuit is the only load imposed at the transformer's secondary. When the regulator reaches the specified regulated voltage based on zener diodes Z1 and Z10, transistor Q1 generates a signal to turn SCR-1 and SCR-2 on. Since these thyristors form a full wave bridge with diodes D1 and D2 on the transformer module, only the respective forward-biased thyristor will fire. Upon firing, an instant voltage drop is seen at the power supply winding output.

This action forces the diode bridge FWB-1 into a back-biased condition cutting off the power supply winding current flow. Balancing of the primary ampere-turns is, therefore, carried out in the low current, or information winding circuit. From this switching point to the next zero crossing, the line current represented in voltage form is obtained across the burden resistor R19. When the line current experiences the next zero-crossing the thyristor is turned off automatically, again allowing the current flow in the power supply winding to charge the regulator circuit. The transformer is designed to allow a large enough current flow in the power supply winding at the pickup level so that the regulated voltage can be established very quickly. Once the regulated supply voltage is ob-

tained, the subsequent replenishment uses only the very initial portion of each half cycle of the current. Therefore, the flux build-up due to the power supply replenishment is very low and the design is capable of providing a linear current information transfer up to 40 times pickup current.

The line current information obtained across burden resistor R19 in voltage form is then utilized using the technique of RC approximation and digital time multiplication for time-current curve sensing. The time current curves generated by this design are closely matched to the ones presently obtained from the electromechanical induction disc type relays. This technique utilizes a short, precision time-constant network for time-current curve shaping, and then uses digital counting and decoding techniques to provide time multiplication and precision time dial selection. This has an advantage over a straight RC approximation scheme since long delay times are required at low multiples of pickup current. Component leakage and other design factors that make the straight RC network type of timing unattractive and complicated are not considered a problem in this digital approach. Thus, the information across resistor R19 is fed through transistor Q4 to this precision multi-branch RC network housed in the plug-in curve module IC-1. Depending upon the degree of inverseness of the desired time-current curve, the number of RC branches may vary from 2 to 4 branches. Each RC branch contains a first order RC circuit with a time-constant different from other branches. The branches are then combined to give a common weighted output. The weighted RC output is then compared with the reference  $V_R$  by IC-6. This operational amplifier maintains a closed-loop operation through Z5 and D8 before the equivalent voltage of the RC network reaches the reference level  $V_R$ . This reference level is set at the minimum pickup condition through the comparator IC-8 (pin 2 output) and potentiometer R5. Once this  $V_R$  reference level is exceeded, IC-6 outputs a negative-going signal which triggers the one-shot circuit (IC-5). The one-shot signal, which has a pulse width adjusted to supply the proper definite delay time (potentiometer R6), resets the multi-branch RC network by turning transistor Q4 off, through Q5 and Q6, and by turning Q7 on to discharge the RC capacitors.

The one-shot signal also advances the binary counter circuit IC-4. This counter, which is enabled (logic 0 on pin 11) when the input current is above the minimum pickup level and reset or kept inactive when below minimum pickup level (MPU IC-8 pin 2), counts the negative going signals from the one-shot output. When the correct count is attained, up to the  $2^{12}$  power or 4096 counts, depending upon which binary output is used per respective curve connection in IC-1, the counter output is inverted by comparator IC-9 (pin 13) and then drives the two time-dial decade counter/decoder circuits, IC-3 and IC-2. These two counters, one for tenth time-dial positions and one for unit time-dial positions, are connected to a dual decade thumbwheel switch to provide ninety-nine distinct time-dial settings, which means up to 99 count outputs from the binary counter IC-4. Thus, for example, if the  $2^{10}$  (1024) output of IC-4 is used, up to  $2^{10} \times$  time dial setting (from 1 to 99) actual counts of the RC network takes place before generation of a trip signal. These decade counters, as in the previous case of the binary counter IC-4, are kept inoperative and reset whenever the minimum pickup signal on pin 15 of IC-3 and IC-2 goes to a logic 1, indicating that the input current dropped below pickup level.

Thus, when the set time dial count has elapsed, a positive output occurs from both the decade counters. These are applied through the time dial switches to the cathode ends of D9 and D10, reverse biasing them. This allows the signal present on pin 8 of comparator IC-8 to now become a logic 1 (through R8) generating a trip signal (IC-8 pin 14). Prior to this, the signal on pin 8 of comparator IC-8 was kept at a logic 0 level by the shorting of this input, in accordance with the logic 0 outputs of IC-3 and IC-2, through either or both of diodes D9 and D10.

This trip signal is then applied through IC-9, D12 and Z6 to the base of Q3, turning it on. This, in turn, applies 3 distinct branch signals; one is through D13, IC-9 and D18 to gate the trip thyristor SCR-4, the second is through D13, IC-9 and D5 to turn on SCR-3, and the third is through D16 to IND-2, the time-delay trip indicator. Thus, with the turn on of SCR-4 a trip output occurs on terminal 1 of the SCO relay. The turn on of SCR-3

crowbars the front end circuitry to prevent overheating of components at high multiples of minimum pickup current, and to insure a minimum relay reset time. The turn on of the indicator can only occur when SCR-4 turns on, and is concurrent with the flow of trip coil current. This signal can flow through D20 in the reverse direction on a summation of currents principle when SCR-4 turns on and allows trip coil current to flow in the forward biasing direction through D20 allowing the indicator current to thereby flow to power supply negative on the anode side of D20. The other path which the indicator current can take is through the trip coil, station battery or its loading, back into the relay (terminal 10), through D19, and finally through SCR-4, when it is turned on, to power supply negative on the cathode side of SCR-4.

The trip of the breaker will interrupt the current input, and since the input or front end circuitry was already "crowbarred" by SCR-3, total reset of the relay circuitry occurs within 50 milliseconds. Reset of the indicator is accomplished manually through use of the reset lever actuated from the outside of the case. This lever magnetically flips the indicator back to its reset state.

The instantaneous trip circuitry also derives its information from the voltage across resistor R19. This information is taken from the cathode side of diode D1, through the instantaneous trip cutout link jumper, to the level control and filter circuitry on the input of the instantaneous trip comparator, IC-8 (pin 6). This input is then compared with the minimum pickup reference level  $V_R$  by IC-8. The potentiometer R18 allows a continuous range of setting from 1 to 40 times the minimum pickup tap setting of the relay. Once the  $V_R$  reference level is exceeded, IC-8 (pin 1) outputs a negative-going instantaneous trip signal. This signal is then applied through IC-9 and Z8 to the base of Q2, turning it on. This, in turn, applies 4 distinct branch signals; one is through D15 and IC-7 to immediately seal-in the instantaneous input on IC-8 pin 6, the second is through D14, IC-9 and D18 to gate the trip thyristor SCR-4, the third is through D14, IC-9 and D5 to turn on SCR-3, and the fourth is through D17 to IND-1, the instantaneous trip indicator.

With the turn-on of SCR-4 a trip output occurs through the same paths as previously described when initiated by the time delay circuit. Similarly to the time delayed trip indicator, turn on of the instantaneous trip indicator can only occur when SCR-4 turns on, and is concurrent with the flow of trip coil current.

## CHARACTERISTICS

### RANGE

The SCO has taps covering the range of 0.5 to 12 amperes. The tap values are: 0.5, 1.0, 1.5, 2.0, 2.5, 3.0, 3.5, 4, 5, 6, 7, 8, 10 and 12 amperes.

Pickup accuracy  $\pm 5$  percent of tap value for

all taps.

The instantaneous circuit has a range of 1 to 40 times the tap value selection with a continuously adjustable pickup.

### TIME-OVERCURRENT CHARACTERISTICS

The time vs. current characteristics are shown in Figures 7 to 13. These characteristics give the trip time for the various time dial settings when the indicated multiples of tap value current are applied to the relay.

Timing accuracy  $\pm 10\%$  of the characteristics curve for any combination of time dial setting and tap value. Operating time repeatability  $\pm 2\%$  at 25°C. for any given time dial and tap setting.

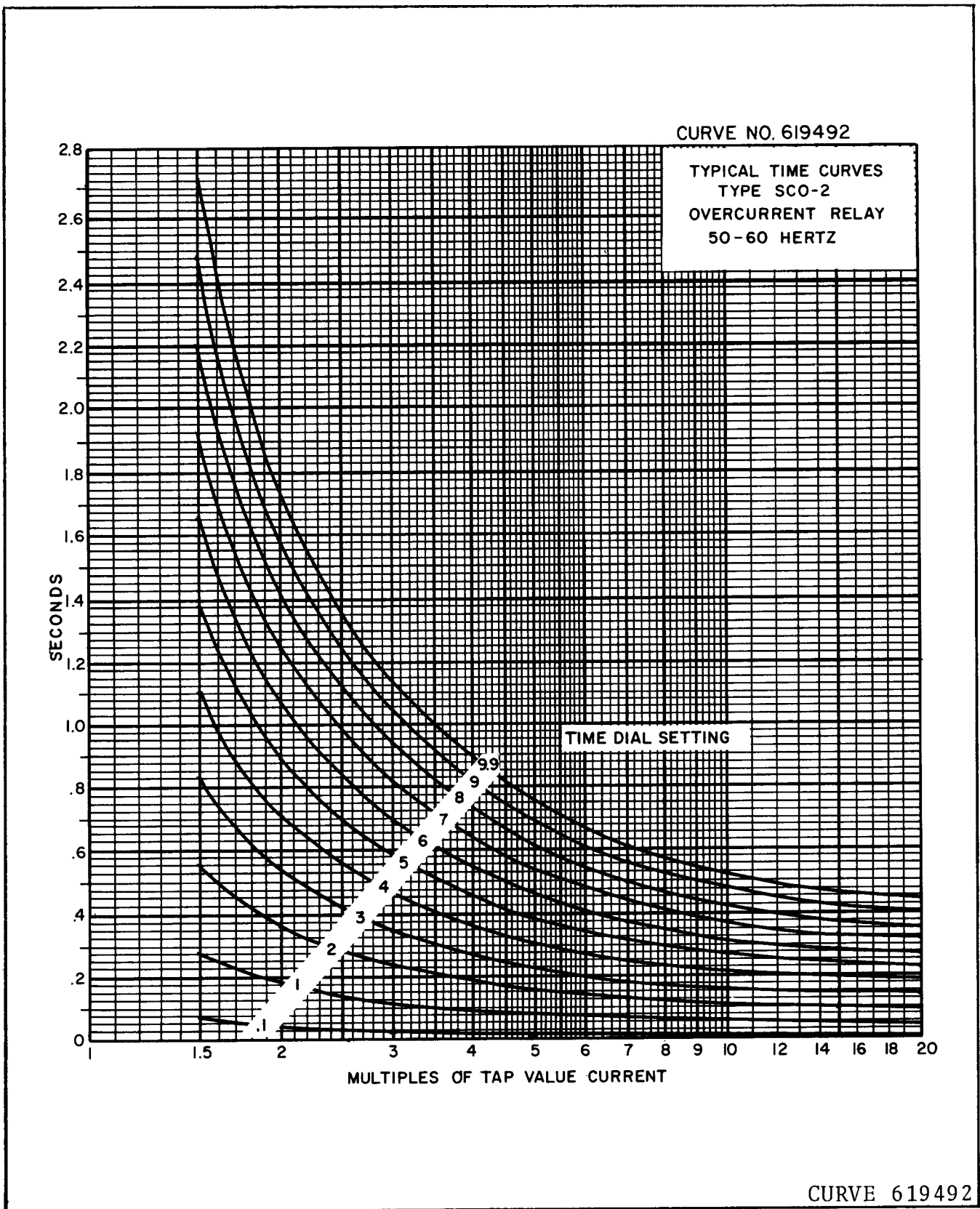

Fig. 7. Typical Time Curves of the Type SCO-2 Relay

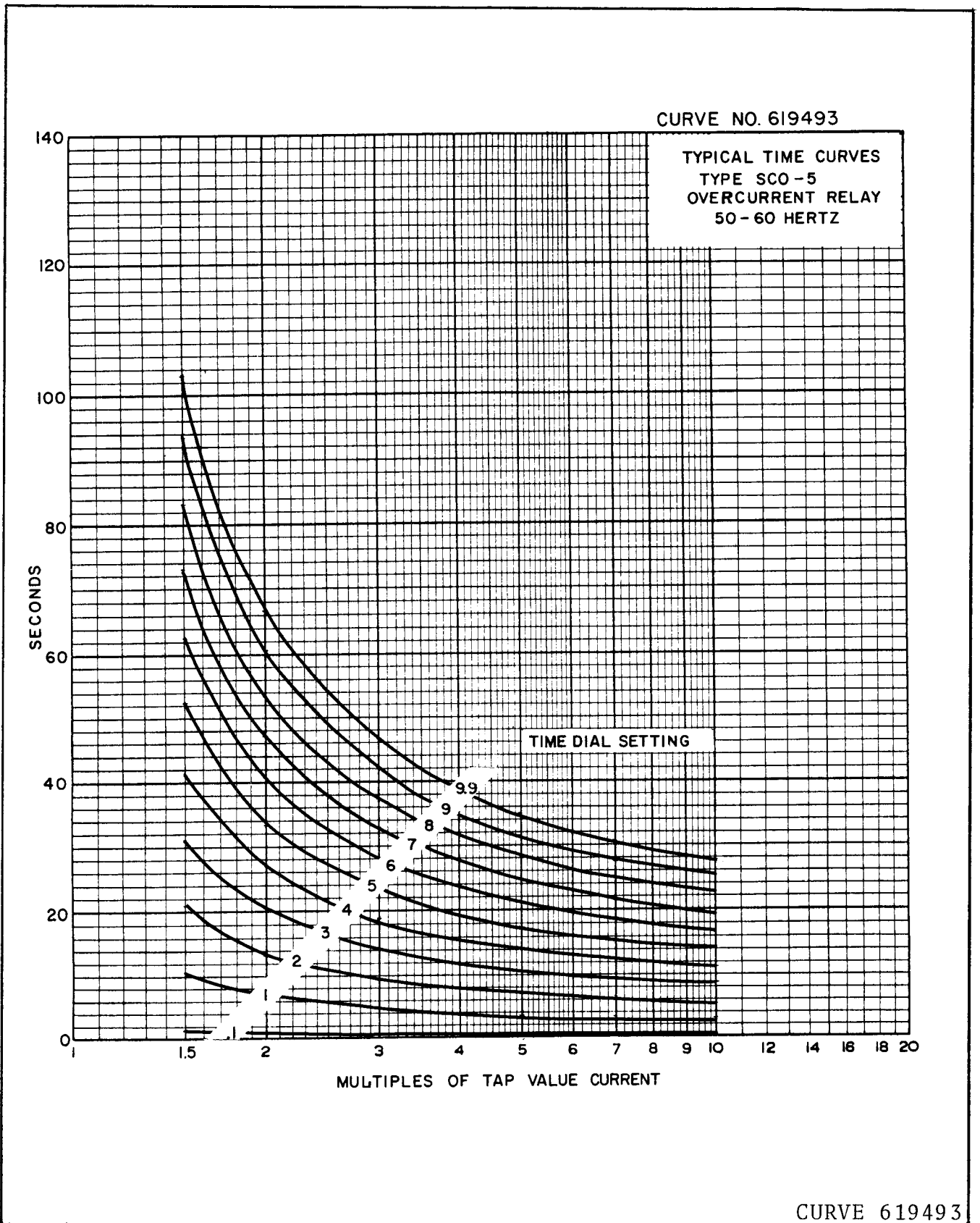

Fig. 8. Typical Time Curves of the Type SCO-5 Relay



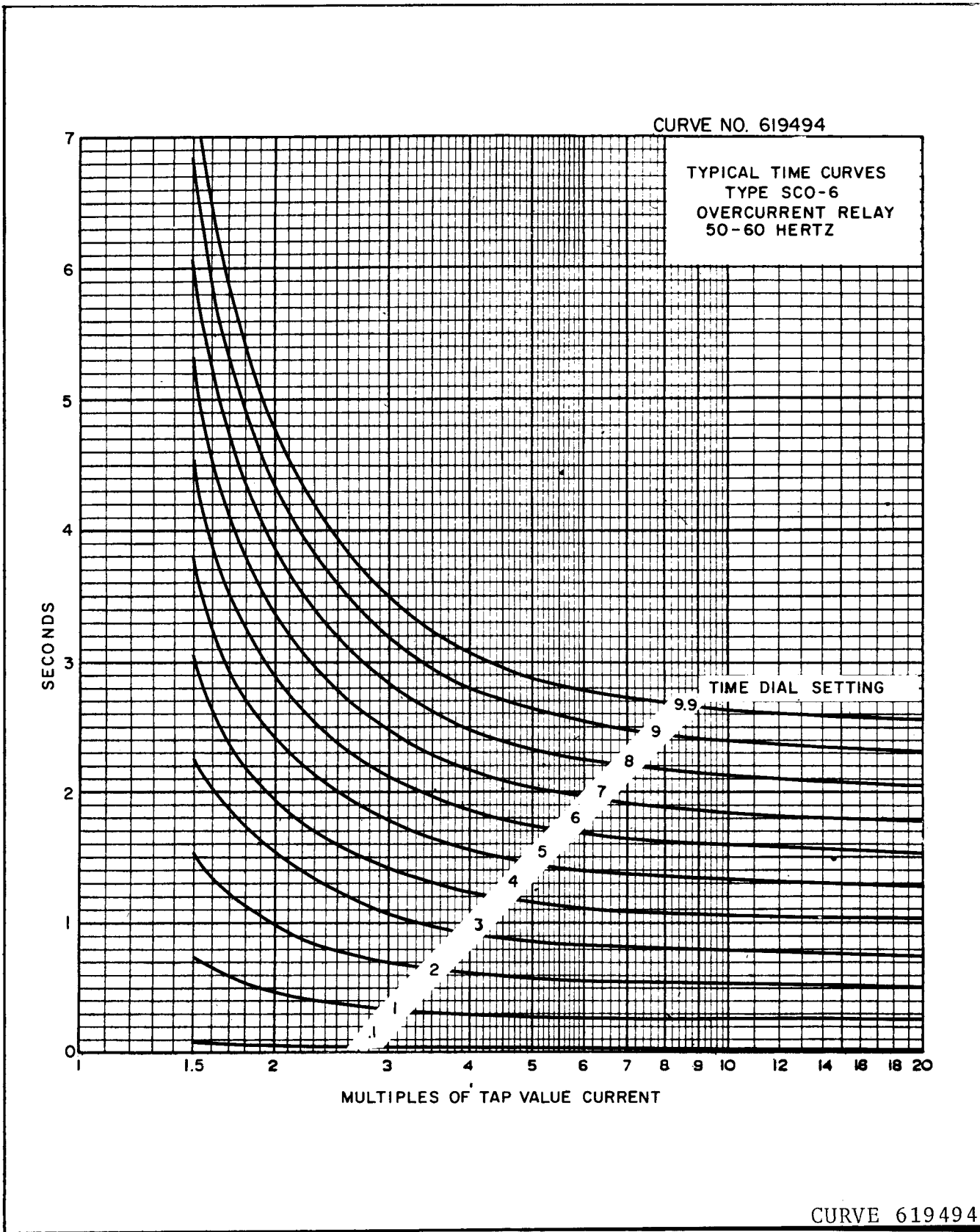

Fig. 9. Typical Time Curves of the Type SCO-6 Relay

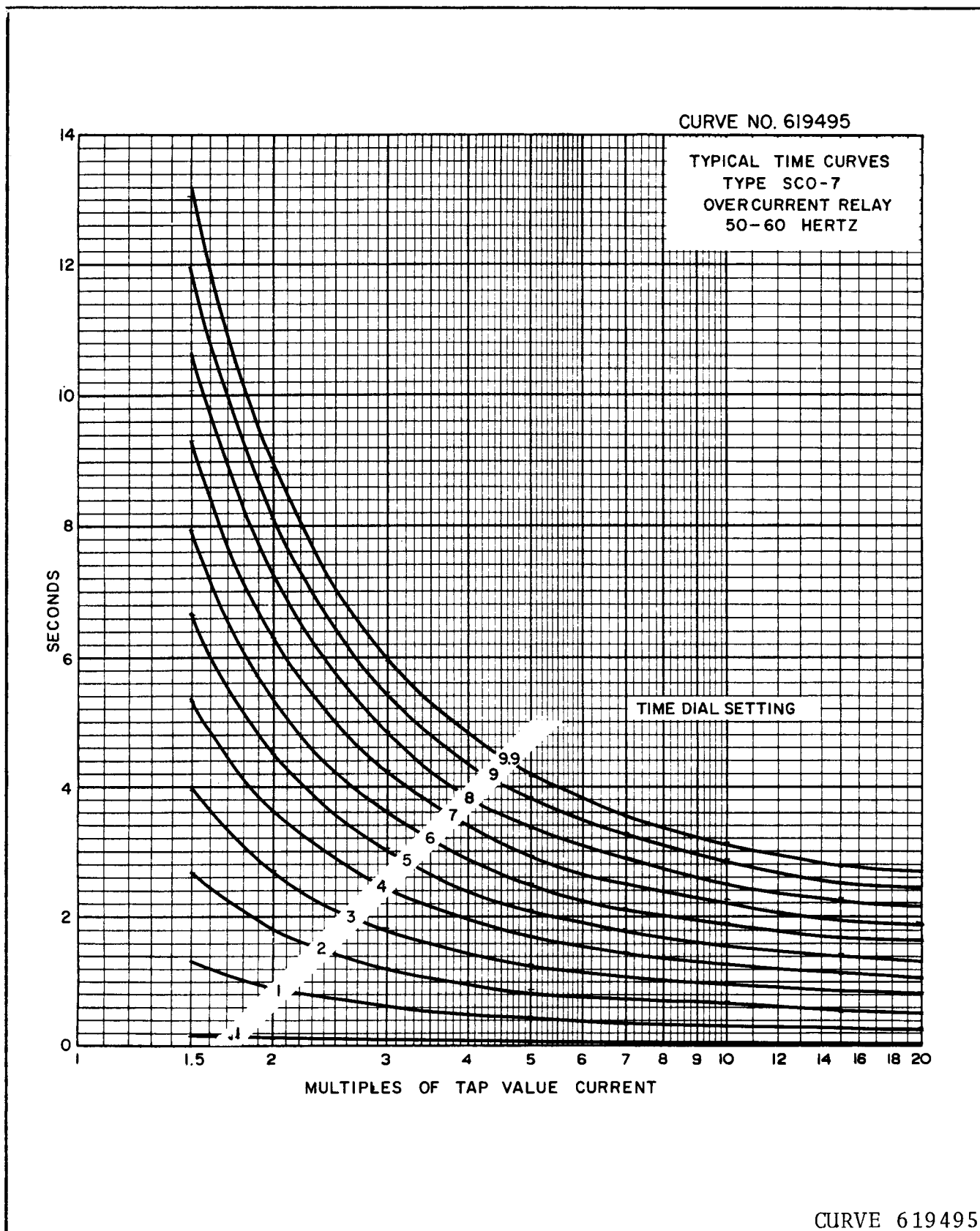
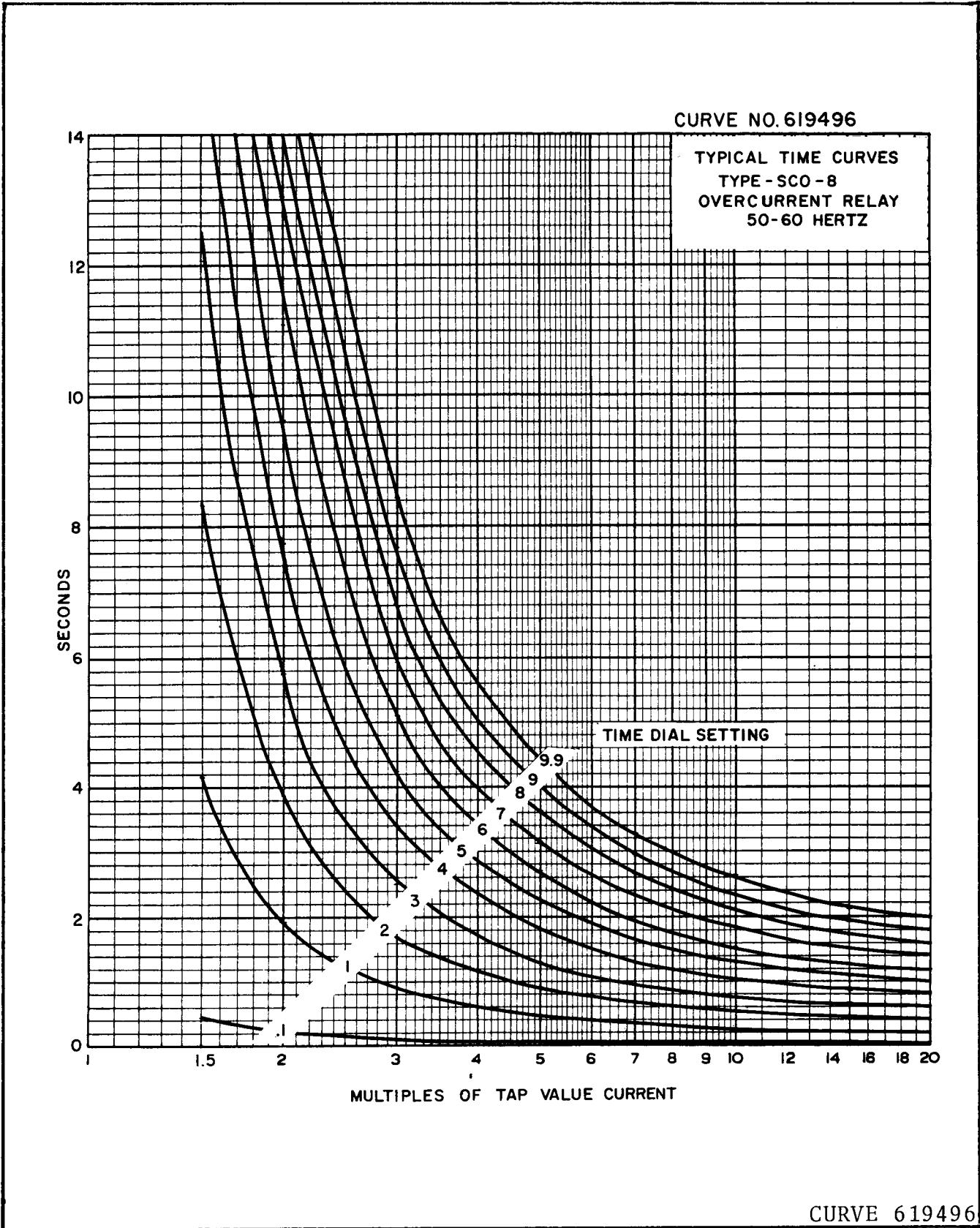

Fig. 10. Typical Time Curves of the Type SCO-7 Relay



CURVE 619496

Fig. 11. Typical Time Curves of the Type SCO-8 Relay

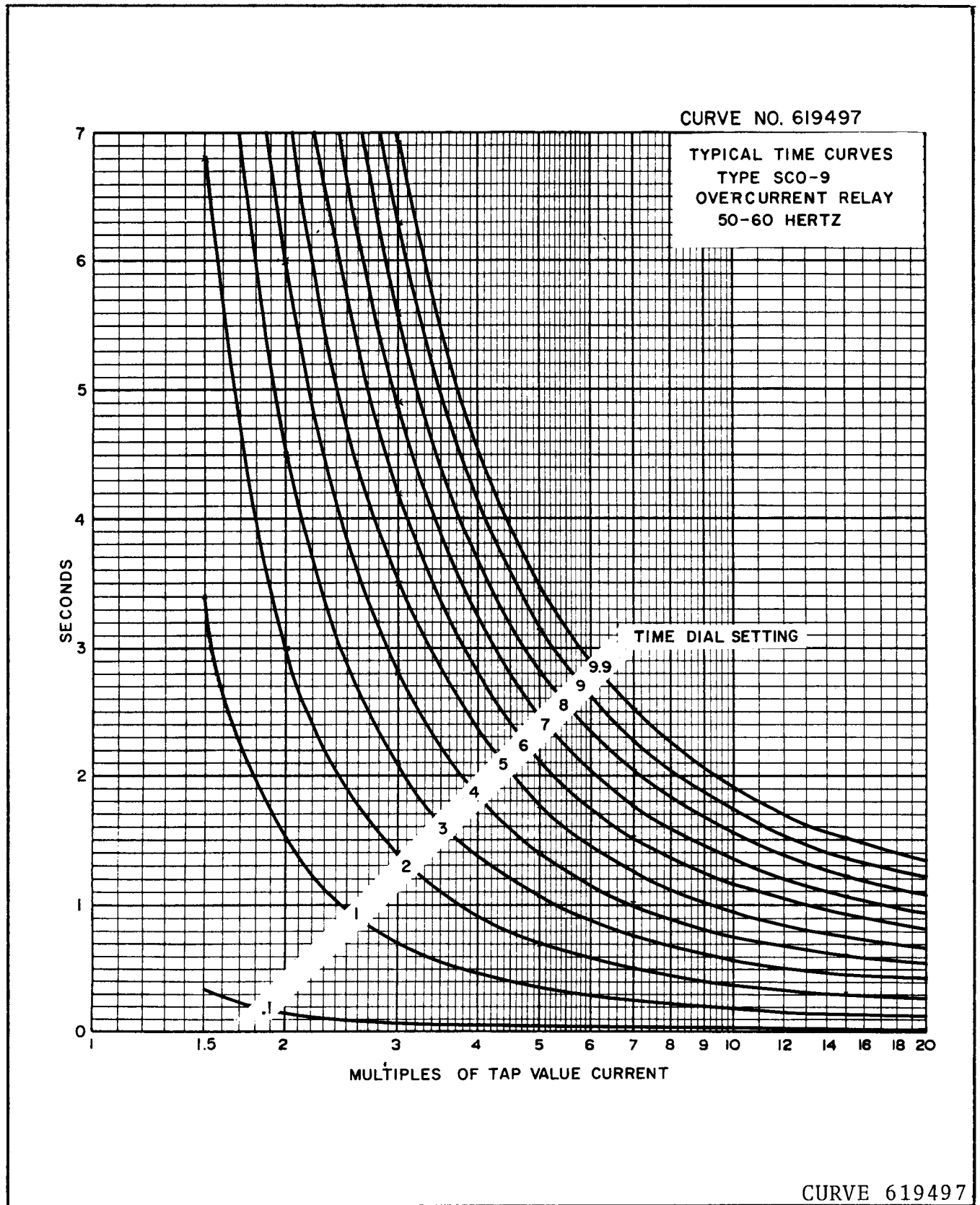
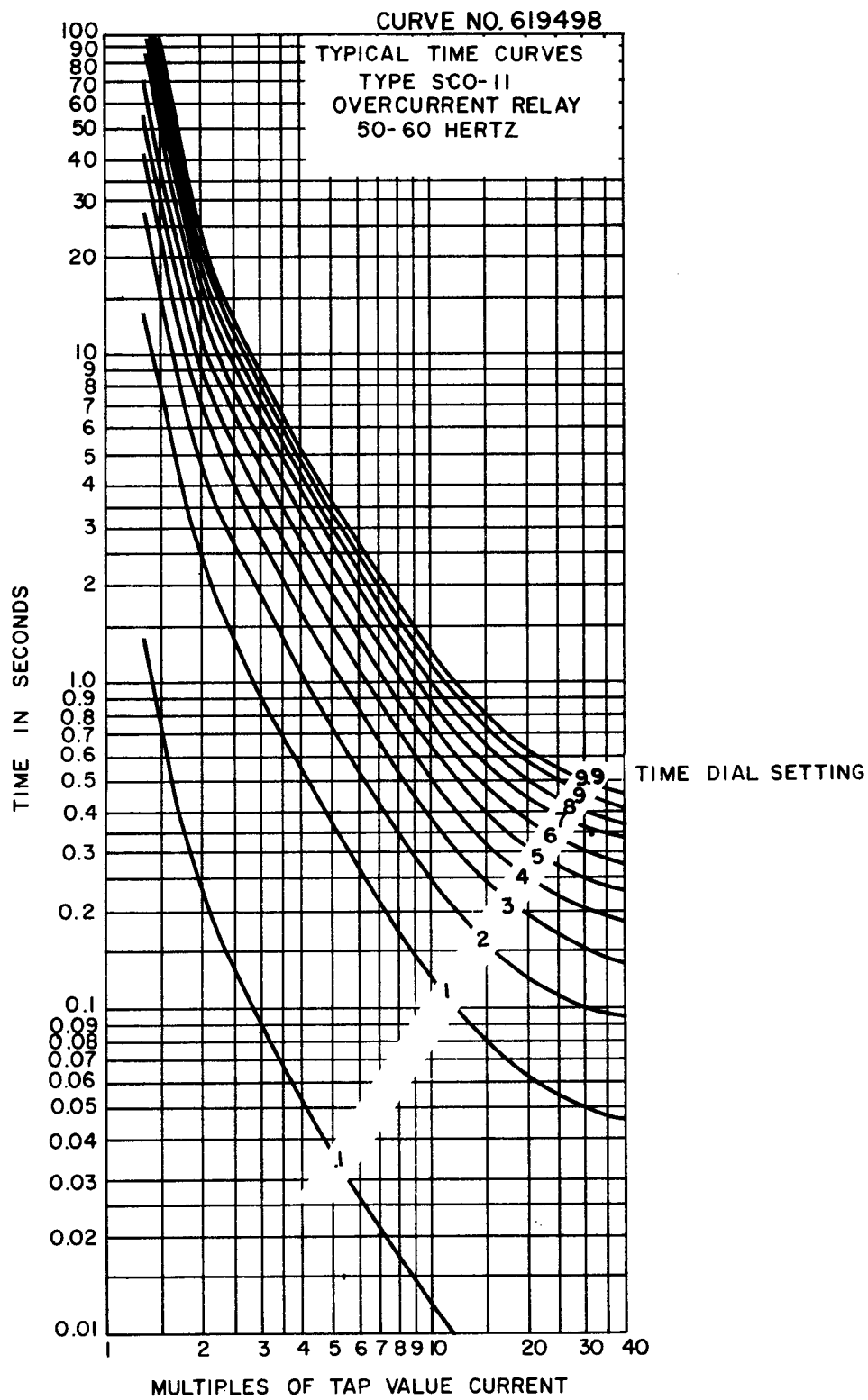

Fig. 12. Typical Time Curves of the Type SCO-9 Relay



CURVE 619498

Fig. 13. Typical Time Curves of the TYPE SCO-11 Relay

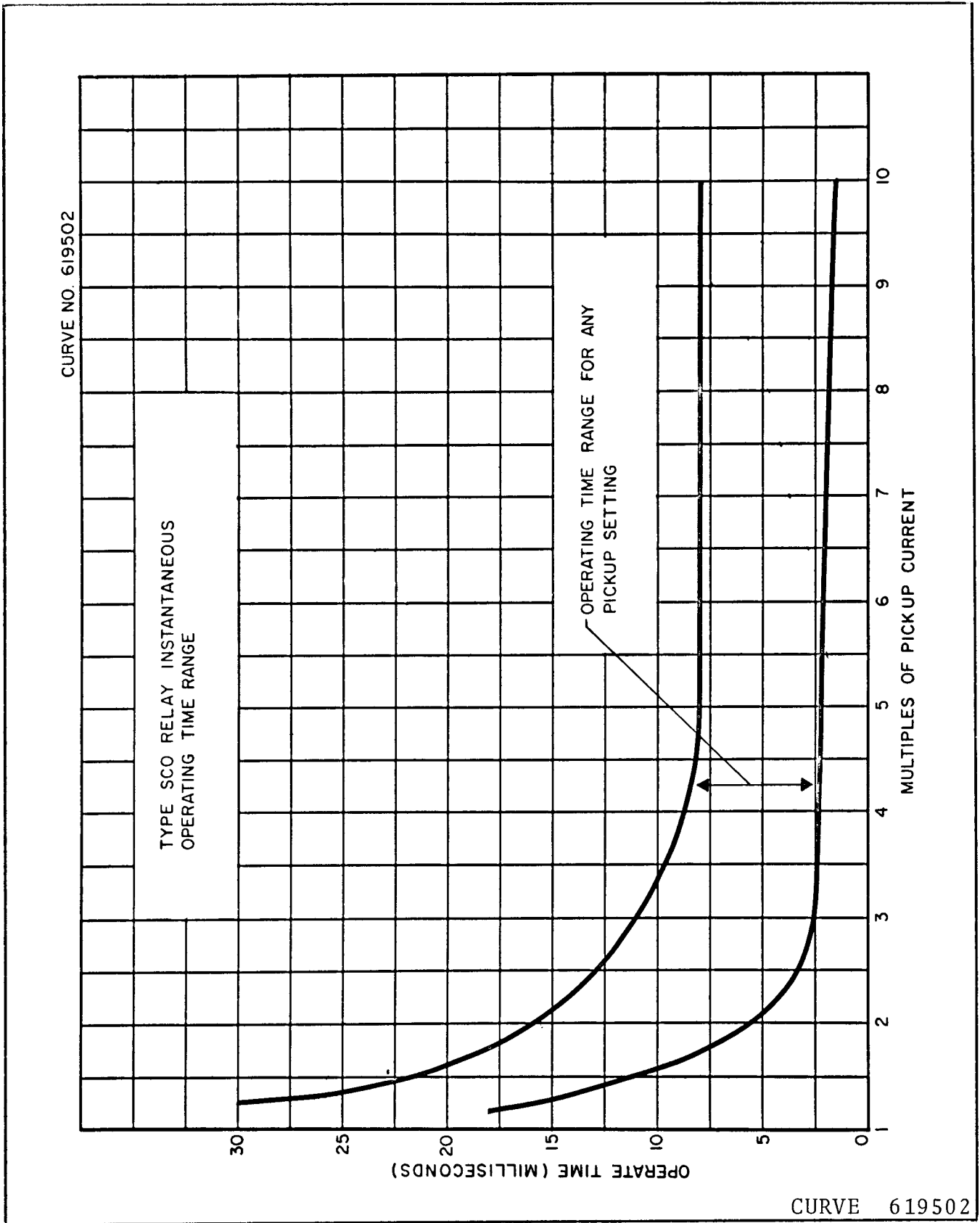

Fig. 14. Typical Time Curve of Type SCO Relay Instantaneous

**INSTANTANEOUS CHARACTERISTICS**

The time vs. current characteristics are shown in Figure 14. These characteristics give the trip time when the indicated multiples of instantaneous pickup current are applied to the relay.

**TRIP CIRCUIT**

The SCO relay energizes the breaker trip coil by means of an output thyristor. This thyristor will safely carry 30 amperes on a 250 volt dc system, or less, long enough to trip a circuit breaker (10 cycles). If the trip current requirement exceeds 30 amperes an auxiliary relay should be used and connected so that tripping current is not conducted through the output thyristor. It should be noted that once the output thyristor is turned on it will remain in conduction until its anode current falls below its holding current, which typically is 5 to 20 milliamperes. Consequently, a 52a contact, or similar contact, should be used to interrupt the trip coil current. It should also be noted that proper polarity should be observed in making the trip output connections since the thyristor must be connected properly, and will not operate if connected reversed. Refer to external scheme Figure 4 for proper trip polarity.

**SURGE WITHSTAND CAPABILITY**

Withstands SWC test per ANSI Standard C37.90A.

**DIMENSIONS**

See Figure 20 for outline dimensions.

**WEIGHT**

Single Phase SCO-Approximately 8 lbs. 2 ozs. (3.69 kilograms).

**TEMPERATURE RANGE**

-20°C to +55°C chassis ambient (outside the relay case) without departure from the +25°C operating accuracy by more than  $\pm 5\%$ .

-30°C to +70°C chassis ambient (outside the relay case) without failure and with no more than 5% additional timing departure. Continuous current ratings must be derated at temperatures above +55°C.

**FREQUENCY**

The typical frequency characteristics of the SCO relay are shown in Figure 15.

**HARMONIC RESPONSE**

The typical response of the SCO relay to harmonics is shown in Figure 16.

**RESET TIME**

The reset time of the SCO relay is less than 50 milliseconds.

**OVERTRAVEL TIME**

The typical overtravel characteristics of the SCO relay is shown in Figure 17.

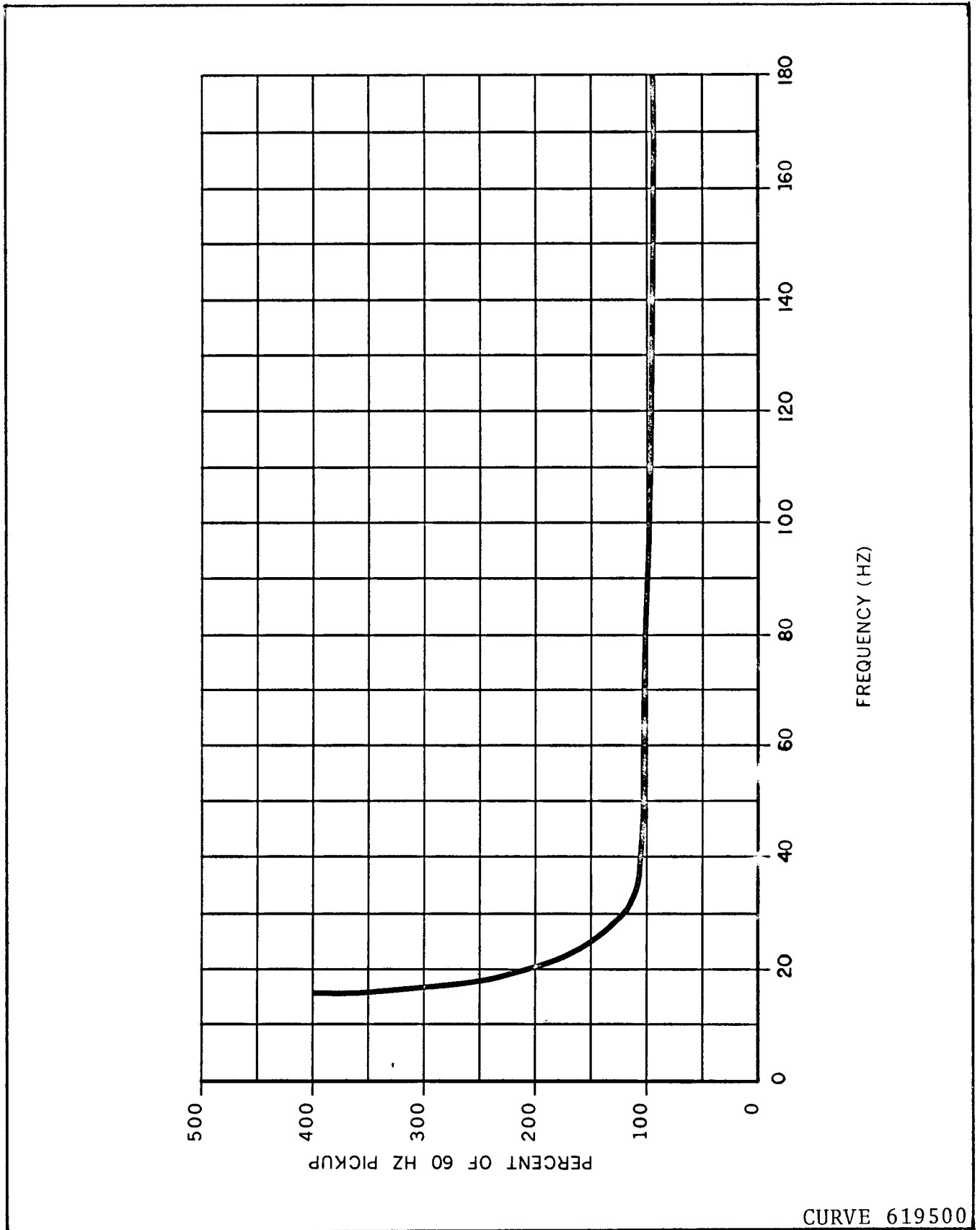
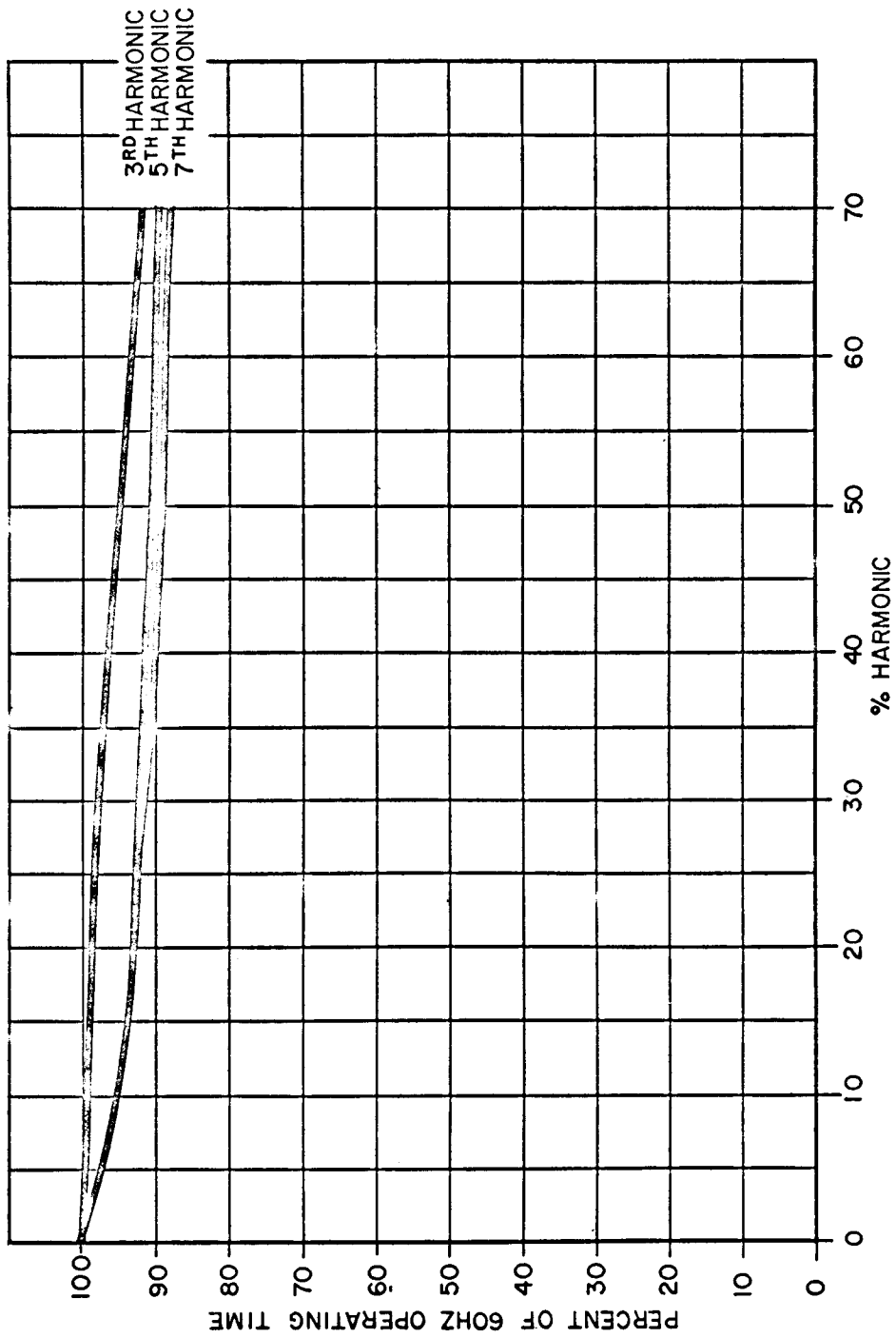

Fig. 15. Typical Frequency Characteristic of the Type SCO Relay





CURVE 619499

Fig. 16. Typical Harmonic Response of the Type SCO Relay

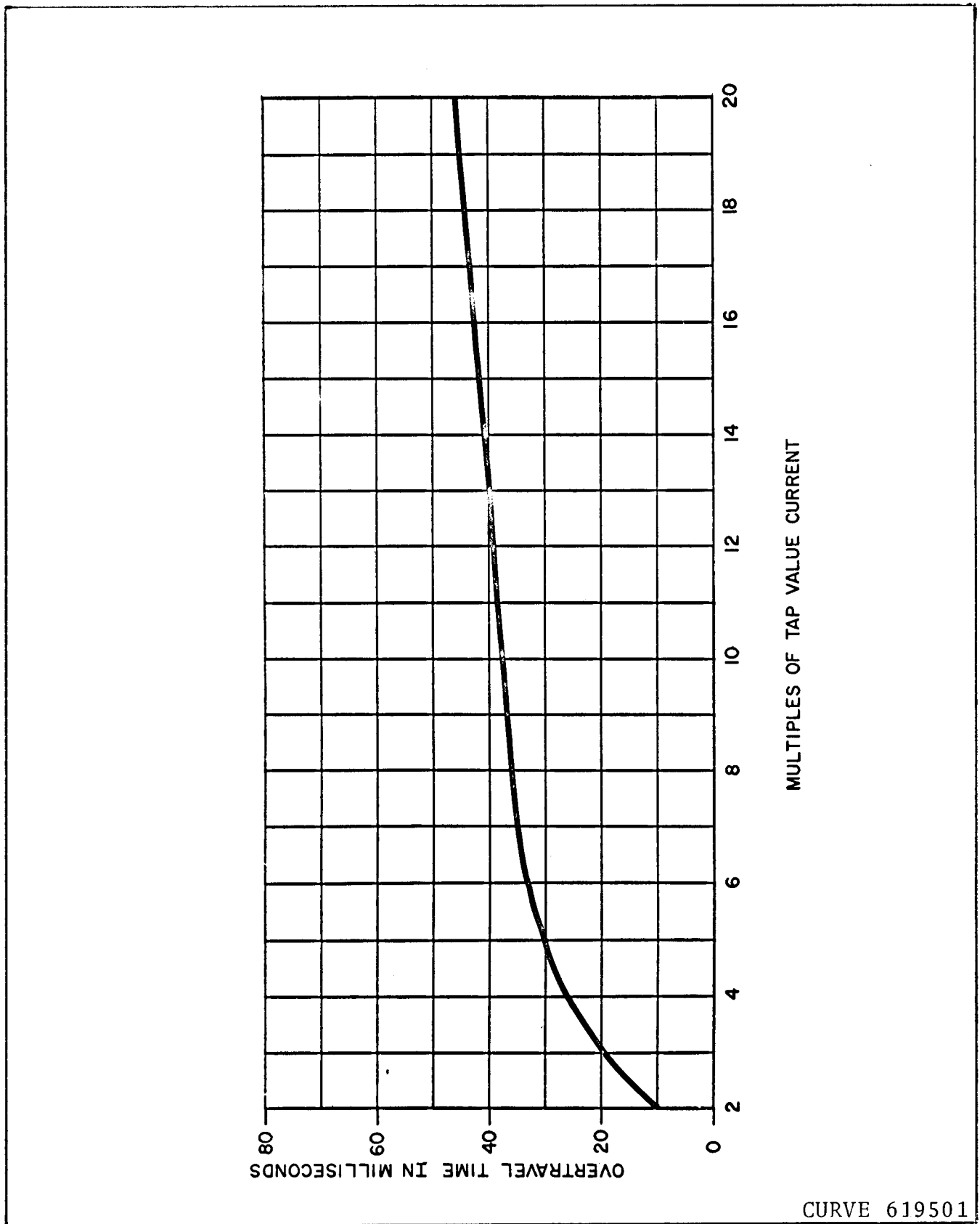

Fig. 17. Typical Overtravel Time of the Type SCO Relay

**TABLE I**  
**ENERGY REQUIREMENTS (60 HERTZ)<sup>1</sup>**

TYPE SCO RELAY WITH INSTANTANEOUS TRIP CIRCUITRY

TAP	CON-TINUOUS RATING (AMPERES)	ONE SECOND RATING <sup>2</sup> (AMPERES)	BURDENS AT TAP VALUE CURRENT			BURDENS IN OHMS <sup>2</sup>		
			R OHMS	X OHMS	Z OHMS	AT 3 TIMES TAP VALUE CURRENT	AT 10 TIMES TAP VALUE CURRENT	AT 20 TIMES TAP VALUE CURRENT
0.5	1.6	44	12.4	0	12.4	3.78	2.32	2.08
1.0	3.3	44	3.0	0	3.0	0.96	0.62	0.58
1.5	4.9	185	1.29	0	1.29	0.41	0.27	0.26
2.0	6.5	185	0.73	0	0.73	0.25	0.17	0.17
2.5	8.1	185	0.48	0	0.48	0.17	0.12	0.12
3.0	9.8	185	0.32	0	0.32	0.12	0.09	0.08
3.5	11.4	185	0.25	0	0.25	0.09	0.06	0.06
4.0	13.0	185	0.19	0	0.19	0.07	0.05	0.05
5.0	16.3	460	0.13	0	0.13	0.05	0.04	0.04
6.0	19.5	460	0.09	0	0.09	0.04	0.03	0.03
7.0	22.8	460	0.08	0	0.08	0.04	0.03	0.03
8.0	25.0	460	0.06	0	0.06	0.03	0.03	0.03
10	29.0	460	0.05	0	0.05	0.03	0.03	0.03
12	29.0	460	0.04	0	0.04	0.02	0.02	0.02

<sup>1</sup>Burdens are approximately 10% lower at 50 hertz.

<sup>2</sup>Thermal capacities for short times other than 1 second may be calculated on the basis of time being inversely proportional to the square of the current (i.e.  $K=I^2t$ )

## SETTINGS

### TIME DELAY

The overcurrent time delay settings can be defined either by tap setting and time dial setting or by tap setting and a specific time of operation at some current multiple of the tap setting (e.g. 4 tap setting, 2.6 time dial setting or 4 tap setting, 0.6 seconds at 6 times tap value current).

The connector screw on the terminal plate of the tap block makes connections to various turns on the input current transformer. By placing this screw in the various terminal plate holes, the tap desired can be set and the relay will respond to multiples of tap value currents in accordance with the various typical time-current curves.

### CAUTION

*Since the tap block connector screw carries operating current, be sure that the screw is turned tight. In order to avoid opening the current transformer circuits when changing taps under load, connect the spare connector screw in the desired tap position before removing the other tap screw from the original tap position.*

The time dial should be set to the desired setting on the two decade time dial thumbwheel switches on the front panel in accordance with the various typical time-current curves.

The time delay must be set to override the normal conditions to which the relay can be subjected, such as motor starting current, cold load pickup, emergency circuit load and transformer inrush.

#### 1. Differential protection

For small transformers and less important buses the SCO differential scheme can be used. A pickup setting above maximum load of any circuit connected to the bus, and a time delay setting for maximum fault current in excess of three times the primary circuit dc time constant, will generally prove to be suitable.

#### 2. Motor protection

For locked rotor protection, the pickup of the SCO is typically set at one half locked rotor

current, and the time delay is set to allow the motor to start without exceeding the allowable locked rotor time for the particular motor.

#### 3. Circuit protection

A pickup setting of two times maximum circuit loading is typical for the phase relay. The circuit load may reach 5 times normal when re-energized after a long time. It may not drop below 2 times normal for approximately 7 seconds. The relay should not trip for this condition. This is the cold load pickup phenomenon and varies widely with the type of load. Devices farther away from the source than the SCO and located between the SCO and the fault should be allowed to clear the fault. For all currents seen by both devices, the SCO curve should be approximately 0.3 seconds above the total clearing time of the remote device. Where consideration to ct performance, fault current variation and relay accuracy a coordinating time equal to or less than 0.2 second plus breaker clearing time may be used.

Ground relay pickup must be above the maximum residual load unbalance, including the effect of switching single phase laterals. A pickup setting corresponding to 0.4 of maximum phase load current is typical. The time curve must be above that of all devices farther away from the source than the SCO. This includes fuses and reclosers even though they may respond to phase current only. 0.3 second coordinating time is adequate. Lower coordinating times may be used as described above.

Similar SCO characteristic shapes at a given system voltage level can generally be more efficiently co-ordinated than dissimilar shapes.

### INSTANTANEOUS TRIP

The instantaneous circuit should be set to the desired setting on the instantaneous tap multiplier potentiometer on the front panel (see CALIBRATION section). This setting is in multiples of tap setting (e.g. with a tap setting of 4 amps. and an instantaneous multiple setting at 20 times, the instantaneous pickup setting will be 80 amps). The relay will respond to currents above this setting per typical time curve Figure 14.

The instantaneous unit is responsive to total current including dc component, and an allowance must be made in the setting to avoid overtripping. Normally a setting of 1.25 times the maximum symmetrical current for which the unit should not trip will provide an adequate margin to prevent undesired tripping due to dc offset.

If an instantaneous trip is not desired in a style relay where it is included, it can be removed from service by cutting out the instantaneous trip cutout jumper located on the right side of the circuit module.

### INSTALLATION

The relays should be mounted on switchboard panels or their equivalent in a location free from dirt, moisture, excessive vibration, corrosive fumes and heat. The maximum temperature outside the relay case should not exceed +55°C for normal operation (See CHARACTERISTICS for temperature range specifications).

Mount the relay vertically by means of the four mounting holes on the flanges for semi-flush mounting or by means of the rear mounting stud or studs for projection mounting. Either a mounting stud or the mounting screws may be utilized for grounding the relay. External toothed washers are provided for use in the locations shown on the outline and drilling plan to facilitate making a good electrical connection between the relay case, its mounting screws or studs, and the relay panel. Ground wires are affixed to the mounting screws or studs as required for poorly grounded or insulating panels. Other electrical connections may be made directly to the terminals by means of screws for steel panel mounting or the terminal studs furnished with the relay for thick panel mounting. The terminal studs may be easily removed or inserted by locking two nuts on the stud and then turning the proper nut with a wrench. See Figure 20 for Outline and Drilling Plan. For detailed FT case information refer to I.L. 41-076.

### ADJUSTMENTS AND MAINTENANCE

The proper adjustments to insure correct operation of this relay have been made at the fac-

tory. Upon receipt of the relay, no customer adjustments other than those covered under "SETTINGS" should be required.

### ACCEPTANCE CHECK

It is recommended that an acceptance check be applied to the SCO relay to verify that the circuits are functioning properly. The SCO test diagram shown in Figure 18 aids in test of the relay. Proper energization of the relay is also shown in this figure.

#### A. Minimum Trip Current

Set the time dial at 0.1, the tap block at 1 amp. and the instantaneous trip potentiometer at maximum setting (40X). Apply current to the relay, starting with a current below the set pickup, and very gradually increase the current applied to 5% below pickup value. The relay should not trip (See characteristic curves for approximate timing). Increase current 5% above pickup value and the relay should trip. The timing indicator (light emitting diode) begins to light in a dim manner at approximately 1% below the pickup point and attains full brightness at the actual minimum pickup level. This same procedure may be used to check the minimum trip current at other tap block settings.

If a more accurate check is desired, an oscilloscope may be used to view the minimum pickup signal. This signal is present on terminal 12 of the sensing-trip module, and is also easily accessible on the top lead of the TIMING light emitting diode by pulling back the insulated sleeving and attaching the scope probe to this point. The current where this signal becomes a solid logic 0 (complete absence of any positive pulses) is the actual minimum pickup point.

#### B. Time Curve

The time curve calibration points for the various types of relays are shown in Table II. With the time dial set to the indicated position, apply the currents specified by Table II (e.g. for the SCO-8, 2 and 20 times tap value current) and measure the operating time of the relay. The operating times should equal those of Table II plus or minus 10%.

#### C. Instantaneous Trip

High multiples of current may be involved in

the following test, therefore, caution should be taken not to exceed the thermal limits specified under CHARACTERISTICS. Starting with the instantaneous trip potentiometer set at minimum, a procedure of raising the potentiometer and applying the desired pickup current should be tried until the instantaneous unit does not operate with the desired current applied (time delay trip may operate). The instantaneous unit setting should then be "backed down and tried" until it does operate with the desired current applied (instantaneous trip indicator operates). The instantaneous will then respond to currents above this setting per the typical time curve Figure 14. If testing the instantaneous trip at higher multiples of pickup where the instantaneous and time delay curves may

overlap, the time dial setting should be raised to the 9.9 setting to give maximum time delay time.

#### D. Trip Indication

The time trip indicator should operate (orange) on time curve trip and be resettable (black) with the reset lever. The instantaneous trip indicator should operate (orange) on instantaneous trip and be resettable (black) with the reset lever.

#### E. Test Trip Switch

The trip test switch, when pushed, should trip the breaker. (Note: No indication occurs on this trip).

At completion of the acceptance test return all settings to desired position.

TABLE II

RELAY TYPE	TIME DIAL POSITION	LOW CURRENT TESTS		HIGH CURRENT TESTS	
		CURRENT APPLIED TIMES TAP VALUE	OPERATING TIME IN SECONDS	CURRENT APPLIED TIMES TAP VALUE	OPERATING TIME IN SECONDS
SCO-2	5.0	2X	.888	20X	.222
SCO-5	5.0	2X	33.5	10X	14.0
SCO-6	5.0	2X	2.42	20X	1.28
SCO-7	5.0	2X	4.50	20X	1.36
SCO-8	5.0	2X	9.66	20X	1.00
SCO-9	5.0	2X	7.50	20X	.675
SCO-11	5.0	2X	10.5	20X	.310

#### ROUTINE MAINTENANCE

All relays should be inspected periodically and all settings and times of operation should be checked at least once every year or at such other intervals as may be indicated by experience to be suitable to the particular application.

#### CALIBRATION

The proper adjustments to insure correct operation of the relay have been made at the factory and should not be disturbed after receipt by the customer. However, recalibration may be required if the adjustments or any components have

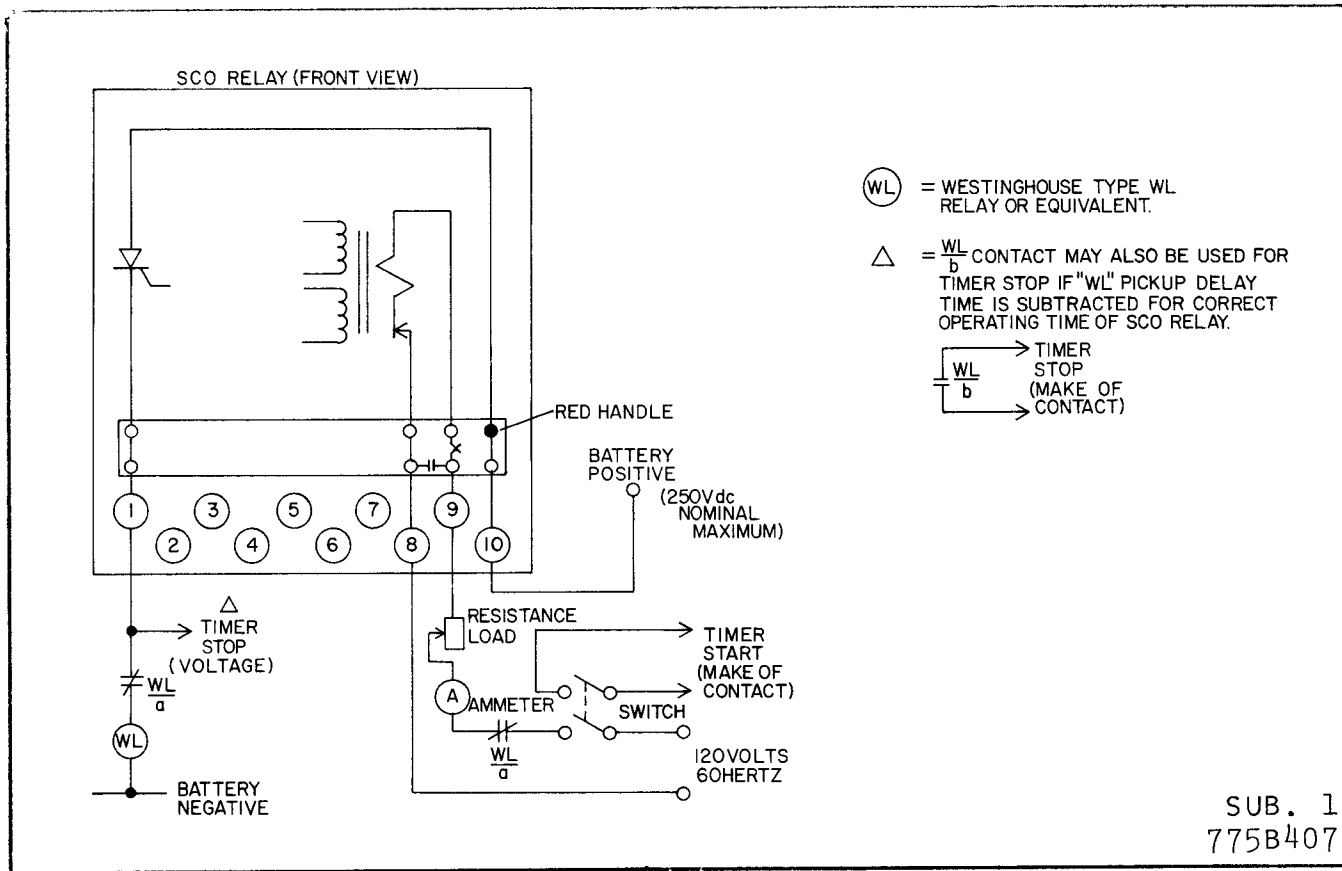

Fig. 18. Diagram of Test Connections for Type SCO Relay

been changed or SCO curve plug-in modules interchanged. This procedure should not be used until it is apparent that the relay is not in proper working order (See "Acceptance Check"). The SCO test diagram shown in Figure 18 aids in test of the relay. Proper energization of the relay is also shown in this figure.

#### A. Minimum Trip Current

Set the time dial at 0.1 setting, the tap block at a 1 amp. setting, and the instantaneous trip potentiometer at maximum setting (40X). Apply minimum current (1amp.) to the relay (terminals 8 and 9). Adjust multi-turn trimpot R5 so that the relay will trip at tap value +1% and not trip at tap value -1%. Counterclockwise rotation of trimpot R5 increases the pickup point, (increases  $V_R$ ) and clockwise rotation of trimpot R5 decreases it. See Figure 2, front photograph, and Figure 6, module component location, for exact location of trimpot R5.

Note that the TIMING indicator (light emitting diode) begins to light in a dim manner at approximately 1% below the pickup point and attains full brightness at the actual minimum pickup level.

An oscilloscope may be used to view the minimum pickup signal. This signal is present on terminal 12 of the sensing and trip module, and is also easily accessible on the top lead of the TIMING light emitting diode by pulling back the insulated sleeving and attaching the scope probe to this point. The current where this signal becomes solid logic 0 (complete absence of any positive pulses) is the actual minimum pickup point. This method is recommended for type SCO-5 and SCO-11 relays which have appreciable trip delays at pickup value.

#### B. Time Curve

Set the tap block at a 1 amp. setting, and set the instantaneous trip at maximum or above 20

times setting so it will not interfere with the time curve trip.

The time curve calibration points for the various types of relays are shown in Table II. Apply current per Table II for 10X or 20X pickup and adjust multi-turn trimpot R6 for the appropriate operating time  $\pm 2\%$ . Clockwise rotation of trimpot R6 increases the trip time and counterclockwise rotation decreases it. See Figure 2, front photograph, and Figure 6, module component location, for exact location of trimpot R6. Apply current per Table II for 2X pickup and check for appropriate operating time  $\pm 7\%$ . Caution should be taken at these higher multiples of current not to exceed the thermal limits of the relay specified under CHARACTERISTICS. A contact to interrupt the input current upon trip of the relay is recommended in testing the SCO relay.

Note: Trimmer capacitor C19 has been factory set for correct operation of IC-6 and should *not* be readjusted. However, if IC-6 is ever replaced, capacitor C19 and trimpot R6 must both be adjusted with a SCO-11 curve module plugged in the relay to obtain correct compensation for IC-6 and correct SCO-11 curve 20X timing value.

### C. Instantaneous Trip

High multiples of current may be involved in the following test, therefore, caution should be taken not to exceed the thermal limits specified under CHARACTERISTICS. Starting with the instantaneous trip potentiometer R18 set at minimum, (fully counterclockwise) a procedure of raising the potentiometer and applying the desired pickup current should be tried until the instantaneous unit does not operate with the desired

current applied (Time delay trip may operate). The instantaneous unit setting should then be "backed down and tried" until it does operate with the desired current applied. (Instantaneous trip indicator operates). The instantaneous unit will then respond to currents above this setting per the typical time curve Figure 14. If testing the instantaneous trip at higher multiples of pickup where the instantaneous and time delay curves may overlap, the time dial setting should be raised to the 9.9 setting to give a maximum time delay time.

No other calibration is necessary other than desired changes in settings.

### TROUBLE SHOOTING

The components in the SCO relay are operated well within their ratings and normally will give long and trouble free service. However, if a relay has given indication of trouble in service or during routine checks, then using the internal schematic Figure 3, component location Figures 5 and 6, and the theory of operation the faulty component, connection, or circuit can be identified.

Voltage levels for "0" and "1" logic states in the theory of operation are:

Logic "0" is equivalent to less than 1 Vdc positive

Logic "1" is equivalent to 5 to 11 Vdc positive.

For those users not generally acquainted with circuit notation or with device symbols of those components used in the SCO drawings, it is recommended that a copy of Westinghouse Instruction Leaflet I.L. 41-000.1 entitled, "Symbols for Solid State Protective Relaying" be consulted.



TYPE SCO SINGLE PHASE RELAY

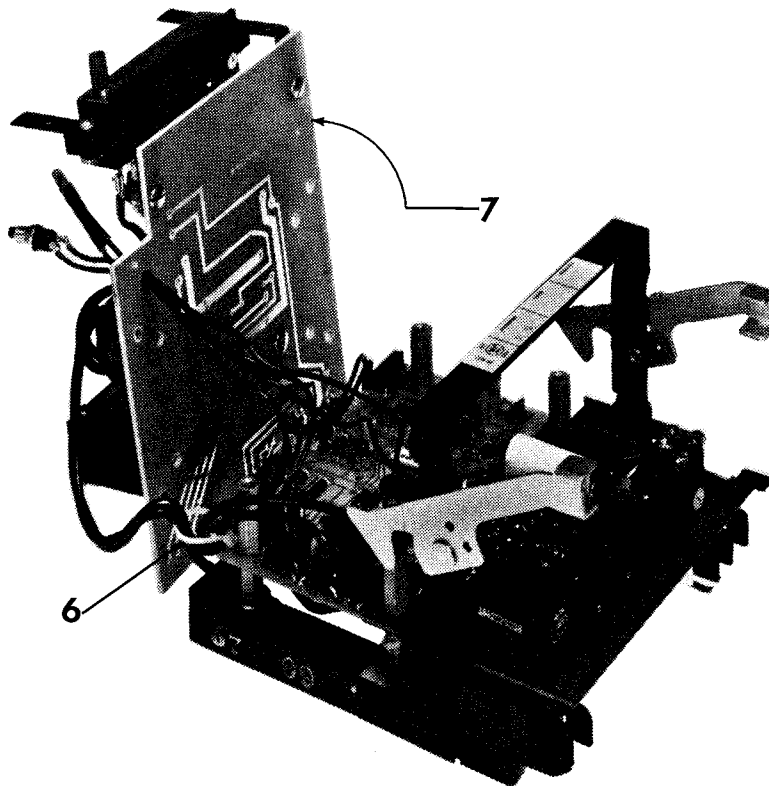
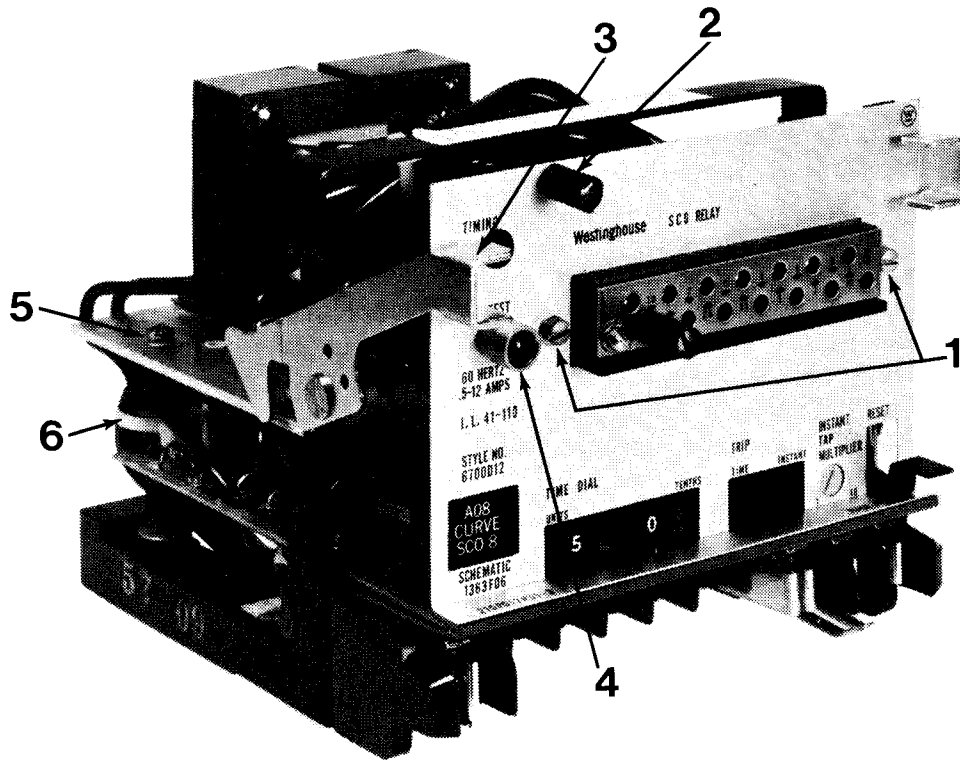

Fig. 19. Disassembly of Type SCO Relay

The SCO relay can easily be disassembled to gain accessibility to all components for ease in trouble shooting. The following procedure should be followed to mechanically detach and slide back the top transformer module when accessibility to components on the bottom module is desired (reference Figure 19):

1. Remove the two nameplate screws.
2. Remove the spare tap screw.
3. Slide back rear retaining ring on TIMING light emitting diode snap bushing (onto wires), and push light emitting diode back through panel.
4. Unscrew shield guard from trip test switch (counterclockwise rotation). Front panel is now free to remove.
5. Remove the four screws holding the top module to posts.
6. Slip the wire tie, which holds the leads in the rear, up over the left rear post.
7. Slide the top module backwards for accessibility to components on bottom module.

Reassembly of the relay is accomplished by reassembling everything disassembled in steps 1 through 7 above in reverse order (7 through 1). Reposition intermodule connecting lead wires in rear of relay back to original routing.

### RENEWAL PARTS

Repair work can be done most satisfactorily at the factory. However, interchangeable parts can be furnished to the customers who are equipped for doing repair work. Internal Schematic Figure 3 contains a complete list and description of the components for renewal parts. When ordering parts, always give complete nameplate data and appropriate Westinghouse style numbers.

### PLUG-IN CURVE MODULES

Plug-in curve modules are available to change the particular style and time-overcurrent characteristic curve of the relay. The time curve

module is a 24 pin plug-in module containing the specific circuitry and components for each particular curve style. There are seven different curve module styles corresponding to the SCO-2, SCO-5, SCO-6, SCO-7, SCO-8, SCO-9 and SCO-11 curves. This module plugs into the 24 pin socket on the sensing-trip module and is visible to the front of the relay through a window in the front panel. There the front label on the module completes the last three digits of the style of the relay (printed on the front panel), and also shows which curve the relay is set for i.e. "SCO-2 curve". Thus, changing this module automatically changes the style of the relay.

When changing plug-in curve modules, the relay should be recalibrated for minimum pickup and time curve specifications per the Calibration Section of this instruction leaflet.

The following are the style numbers of the plug-in curve modules available:

Relay Type	Curve Module	Time Curve	Curve Module Plug-In Style
SCO-2	A02	Short	1442C29G02
SCO-5	A05	Long	1442C29G05
SCO-6	A06	Definite	1442C29G06
SCO-7	A07	Moderately Inverse	1442C29G07
SCO-8	A08	Inverse	1442C29G08
SCO-9	A09	Very Inverse	1442C29G09
SCO-11	A11	Extremely Inverse	1442C29G11

Consult Type SCO Time Curve Plug-in Modules Instruction Leaflet I.L. 41-110.2 for further information on SCO plug-in curve modules.

**TYPE SCO SINGLE PHASE RELAY**

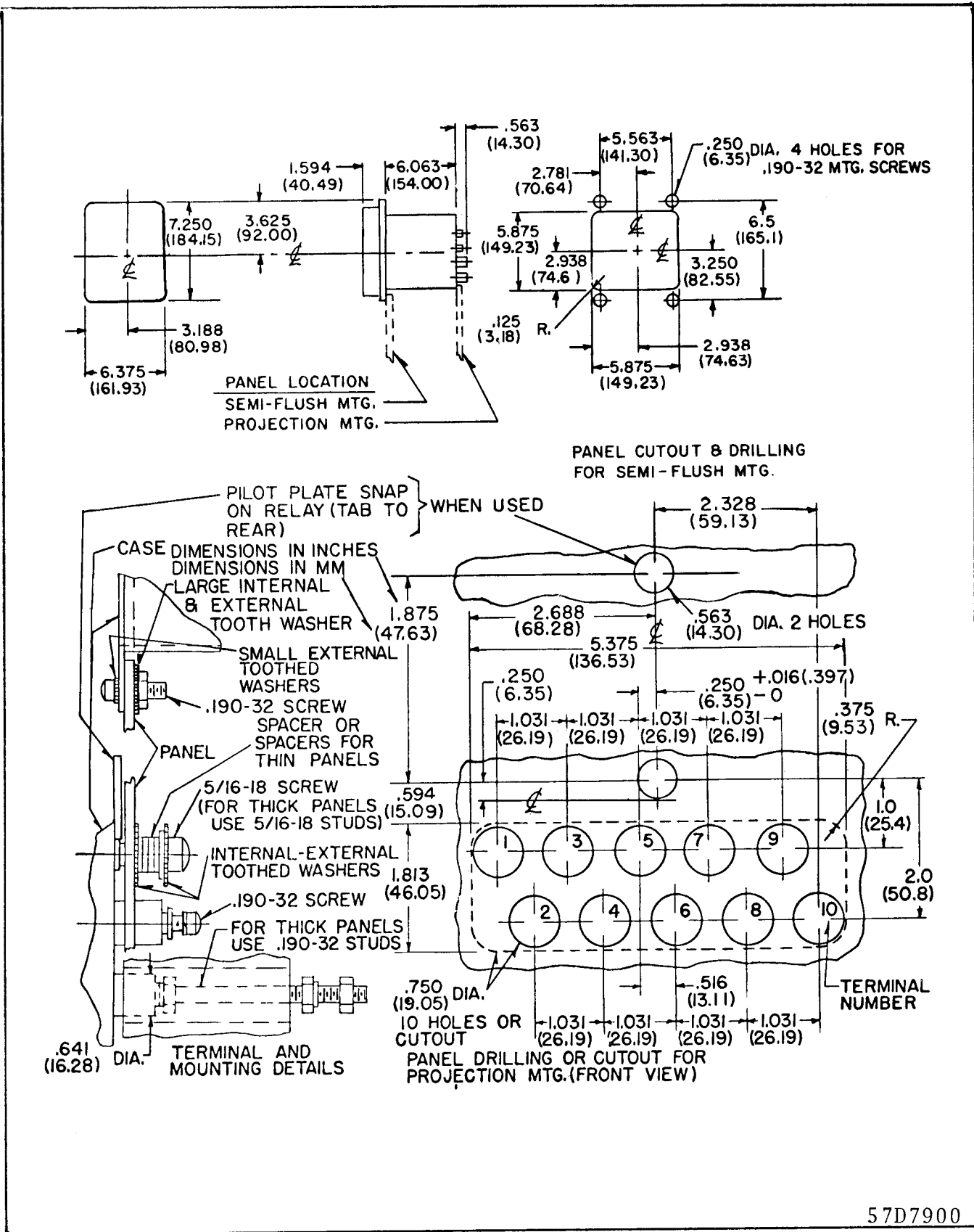

57D7900

Fig. 20. Outline and Drilling Plan for Type SCO Relay Single Phase in FT-11 Case

**WESTINGHOUSE ELECTRIC CORPORATION**  
**RELAY-INSTRUMENT DIVISION**  
**NEWARK, N. J.**

Printed in U.S.A.