

INSTRUCTION MANUAL

FOR

OVERCURRENT RELAY

BE1-50/51M-222

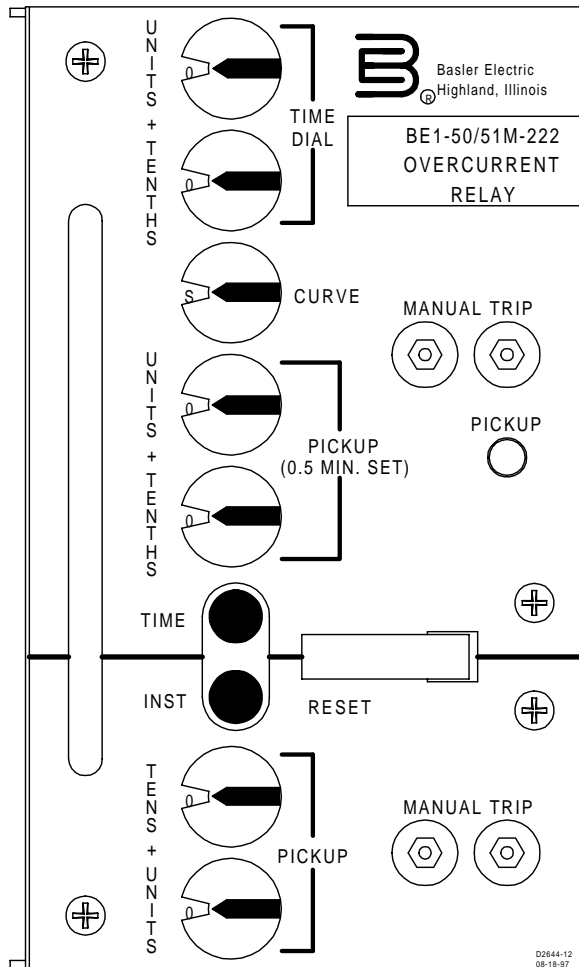

B Basler Electric

Publication Number: 9 2520 00 984
Revision: A 12/99

INTRODUCTION

This manual provides information concerning the operation and installation of the BE1-50/51M-222 Overcurrent Relay. To accomplish this, the following is provided.

- Specifications
- Functional description
- Mounting information
- Setting procedure/example.

WARNING!

To avoid personal injury or equipment damage, only qualified personnel should perform the procedures presented in this manual.

First Printing: August 1997

Printed in USA

© 1997, 1999 Basler Electric Co., Highland, IL 62249

December 1999

CONFIDENTIAL INFORMATION

OF BASLER ELECTRIC COMPANY, HIGHLAND, IL. IT IS LOANED FOR CONFIDENTIAL USE, SUBJECT TO RETURN ON REQUEST, AND WITH THE MUTUAL UNDERSTANDING THAT IT WILL NOT BE USED IN ANY MANNER DETRIMENTAL TO THE INTEREST OF BASLER ELECTRIC COMPANY.

It is not the intention of this manual to cover all details and variations in equipment, nor does this manual provide data for every possible contingency regarding installation or operation. The availability and design of all features and options are subject to modification without notice. Should further information be required, contact Basler Electric Company, Highland, Illinois.

**BASLER ELECTRIC, BOX 269, HIGHLAND, IL 62249 USA
PHONE 618-654-2341 FAX 618-654-2351**

CONTENTS

SECTION 1	GENERAL INFORMATION	1-1
	Description	1-1
	Application	1-1
	General	1-1
	Load Demand Curve	1-2
	Specifications	1-3
	Characteristic Curves	1-8
SECTION 2	CONTROLS AND INDICATORS	2-1
SECTION 3	FUNCTIONAL DESCRIPTION	3-1
	General	3-1
	Functional Description	3-1
	Sensing Input	3-1
	Power Supply	3-1
	Instantaneous Signal	3-1
	Time Signal	3-1
	Microprocessor	3-1
	Power-Off Sensing	3-2
	Outputs	3-2
SECTION 4	INSTALLATION	4-1
	General	4-1
	Dielectric Test	4-1
	Mounting	4-1
	Outline Dimensions	4-2
	Panel Drilling Diagram, C1 Case	4-3
	Connections	4-4
	AC Input Connections	4-4
	DC Control Connections	4-5
	BE1-50/51M-222 Overcurrent Relay, Rear View	4-6
SECTION 5	TESTING	5-1
	General	5-1
	Dielectric Test	5-1
	Operational Test Procedure	5-1
	Test Equipment Required	5-1
	Pickup and Timing Test Setup	5-2
	Target Operational Test Setup	5-2
	Test Procedure	5-3
	Setting the Relay	5-6
	Periodic Tests	5-6
	General	5-6
	Periodic Test	5-6

CONTENTS - Continued

SECTION 6 MAINTENANCE	6-1
General	6-1
In-House Repair	6-1
Storage	6-1
Periodic Tests	6-1
General	6-1
Periodic Test	6-2
SECTION 7 MANUAL CHANGE INFORMATION	7-1

SECTION 1

GENERAL INFORMATION

DESCRIPTION

BE1-50/51M-222 Overcurrent Relays are microprocessor based, non-directional phase or ground relays that monitor the magnitude of a single phase ac current to provide accurate instantaneous and time overcurrent protection for 50 hertz or 60 hertz power systems. The BE1-50/51M-222 Overcurrent Relay is a special, modified relay with software for a *Load Demand Characteristic Curve* in place of the short inverse standard curve. To select the *Load Demand Characteristic Curve*, position the CURVE select switch to position S.

APPLICATION

General

The wide range of pickup settings and front panel selectable time characteristics permit applications involving coordination with fuses, reclosers, cold load pickup, motor starting, and fixed time requirements. Integrating reset functions are available to simulate the disk reset of electromechanical relays. BE1-50/51M-222 Overcurrent Relays have the following standard features.

- Independent time and instantaneous elements.
- A secure method to manually trip the breaker at the relay front panel.
- Direct reading front panel controls.
- Minimum pickup setting for safety during installation.
- Time characteristics extend to a pickup multiple of 40.
- Rugged draw-out construction with steel case.
- Magnetic latching targets retain indication without power.
- Built-in accuracy eliminates internal adjustments.
- Minimum transient overreach.
- Field selectable instantaneous or integrating reset.
- Field selectable 50 or 60 hertz operation.
- Field selectable fixed instantaneous delay (0.0, 0.1, 0.2, or 0.3 second).

Individual models are available for 1 ampere and 5 amperes sensing input currents. BE1-50/51M-222 Overcurrent Relays must be removed from the case and installed on a test bench for testing. Shorting contacts are provided for all current inputs when the relay chassis is removed from the relay case. Figure 1-1 shows the front panel of the BE1-50/51M-222 Overcurrent Relay, in a C1, vertical mount case.

BE1-50/51M-222 Overcurrent Relays have many advantages over other overcurrent relays. The five primary advantages are:

- Time characteristics are defined by equations and graphs.
- Field selectable time characteristics.
- Very low burden.
- Self powered from the sensed current.
- Continuous automatic calibration.

BE1-50/51M-222 General Information

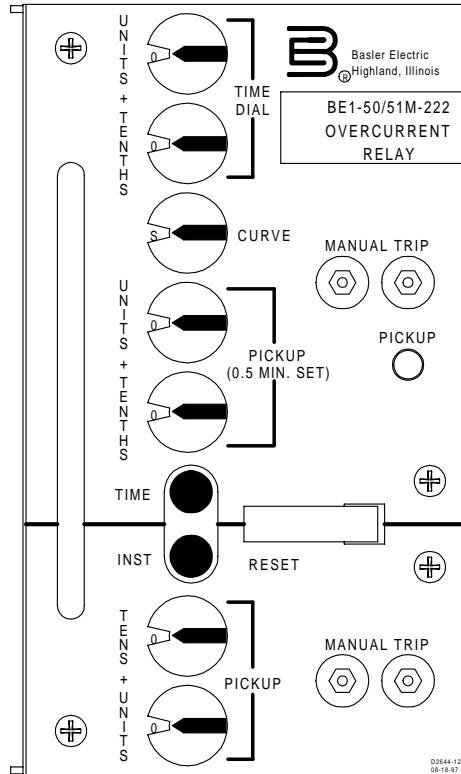

Figure 1-1. BE1-50/51M-222 Overcurrent Relay, C1 Case

Load Demand Curve

Scenario

Configure the relay such that when the sensed current is:

- 1.05 times pickup Time to trip > 1.0 hour
- 1.2 times pickup Time to trip < 1.0 hour
- 1.5 times pickup Time to trip < 2.0 minutes
- 4.0 times pickup Time to trip > 0.2 seconds
- 6.0 times pickup Time to trip < 0.2 seconds

Settings

Position the following switches as designated. (Switch locations are shown in Section 2, *Controls And Indicators*.) Figure 1-2 is a graph showing the timing for the application scenario.

- SW8-1 Select nominal operating frequency
- SW8-2 OFF (open) no instantaneous delay
- SW8-3 OFF (open) no instantaneous delay
- SW8-4 ON (closed) integrating reset selected
- TIME DIAL 4.0
- CURVE S
- TIME PICKUP Select preferred time pickup level
- INST PICKUP Select preferred instantaneous pickup level

BE1-50/51M-222 General Information

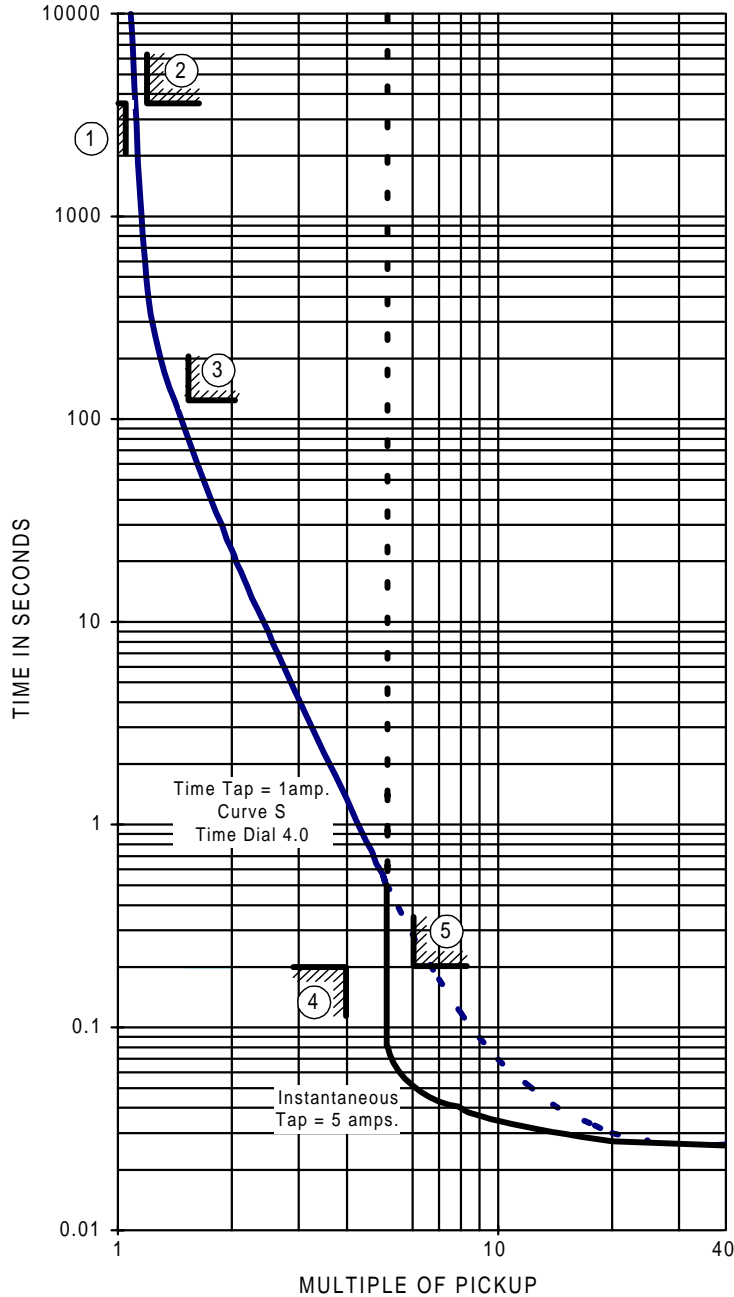

Figure 1-2. Load Demand Characteristic Curve

SPECIFICATIONS

BE1-50/51M-222 Overcurrent Relays have the following features and capabilities.

- | | |
|------------------------------|----------------------------------------------------------------------------------------------------------------------------------------------------------------------------------------|
| Current Sensing Input | Continuous current: 14 amperes. One second current: 400 amperes. |
| TIME PICKUP Range | 0.5 to 15.9 amperes in 0.1 ampere steps. Setting the TIME PICKUP to the minimum pickup (0.5 ampere), places the relay in the most sensitive state and may be used as a safety setting. |
| TIME Dropout | Dropout occurs at 95% of pickup value. |

BE1-50/51M-222 General Information

TIME PICKUP

Accuracy

$\pm 2\%$ ± 25 milliamperes at or above 0.5 ampere settings.

Frequency Response

A change of ± 5 hertz from the nominal 50/60 hertz current causes less than 0.5% change in the current required for pickup.

TIME DIAL Range

0.0 to 9.9, in 0.1 steps.

INST PICKUP Range

1 to 99 amperes in 1 ampere steps. Setting the INST PICKUP to the minimum pickup (1.0), places the relay in the most sensitive state and may be used as a safety setting.

INST Dropout

Dropout occurs at 95% of pickup value.

INST PICKUP

Accuracy

$\pm 2\%$ ± 25 milliamperes at or above 1.0 ampere settings.

Frequency Response

A change of ± 5 hertz from the nominal 50/60 hertz current causes less than 0.5% change in the current required for pickup.

INST Transient Response

Less than 10% overreach with system time constants up to 40 milliseconds.

Burden

Burden is non-linear. At 0.5 amperes, $Z = 4.8$ ohms. At 5.0 amperes, $Z = 0.2$ ohms. (Figure 1-3 illustrates the device burden.)

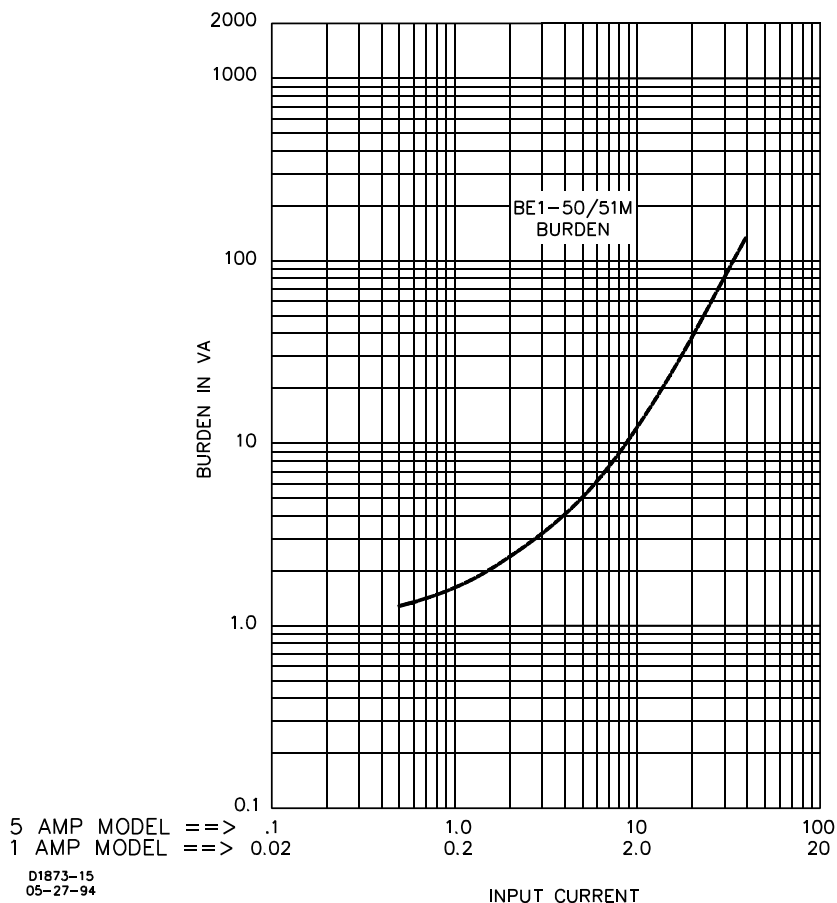

Figure 1-3. Device Burden Characteristics

BE1-50/51M-222 General Information

Harmonic Response

BE1-50/51M-222 harmonic rejection is illustrated in Figure 1-4.

Figure 1-4 shows that a relay set for one ampere pickup would pickup at 0.96 ampere on a current containing 40% seventh harmonic. This corresponds to a ten-to-one rejection ratio. Other conditions may be evaluated in the same manner.

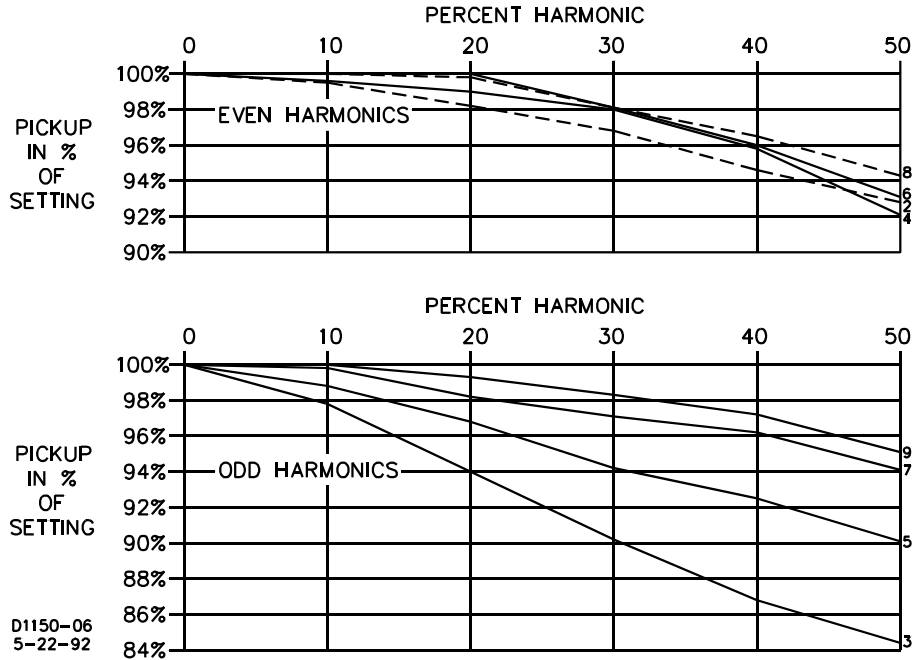

Figure 1-4. Harmonic Response

INST Characteristics

BE1-50/51M-222 instantaneous characteristic curves are similar to standard electromechanical instantaneous units. However, the time to trip for ground applications is slightly longer than that for phase applications to allow time to power-up the relay. Longer trip time for ground applications is beneficial because it helps to avoid nuisance trips.

For phase applications, the maximum time to trip is 3.5 cycles at a pickup multiple of 1.0, and 1.5 cycles at a pickup multiple of 3.0. The corresponding times for ground applications are 4.5 and 1.75 cycles. Figure 1-5 shows the instantaneous characteristic curves for maximum time to trip.

Additional delays of 0.1, 0.2, or 0.3 seconds may be added with internal switches SW8-2 and -3. These delays apply to both phase and ground applications. Closing switch SW8-2 provides an additional delay of 0.1 second. Closing switch SW8-3 provides an additional delay of 0.2 second. Closing both switches SW8-2 and -3 provides an additional delay of 0.3 second. Section 2 illustrates the location of SW8.

Time Characteristics

Nine inverse time functions and one fixed time function can be selected by a front panel switch.

BE1-50/51M-222 General Information

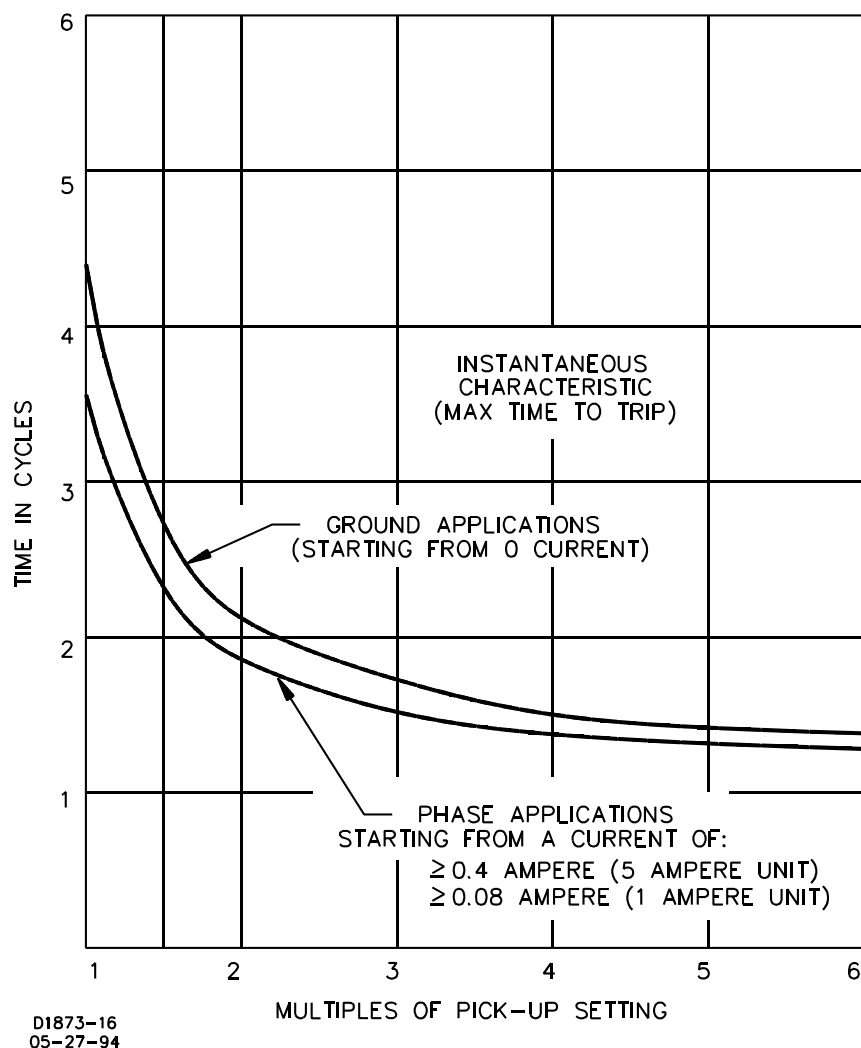

Figure 1-5. Instantaneous Characteristic Curves

Time Reset

Reset occurs when the current drops below pickup and the relay has not timed out. Switch SW8-4 provides selection of either an instantaneous or integrating reset characteristic. Opening SW8-4 forces the instantaneous reset timer to zero when timed dropout occurs. This fast reset characteristic prevents the ratcheting effect that may occur with repeating system faults. Closing SW8-4 selects the integrating reset characteristic. The integrating reset characteristic simulates the disk reset of electromechanical relays. BE1-50/51M-222 relays provide the integrating reset function even when input current falls to zero. Integrating reset characteristics are shown in Figure 1-6.

Target Indicators

Magnetically latched, manually reset targets indicate that current of 0.2 amperes or greater was present in the trip circuit. Target coil resistance is less than 0.1 ohm and operate time is less than one millisecond. See 50/51 Output specifications for maximum current rating.

BE1-50/51M-222 General Information

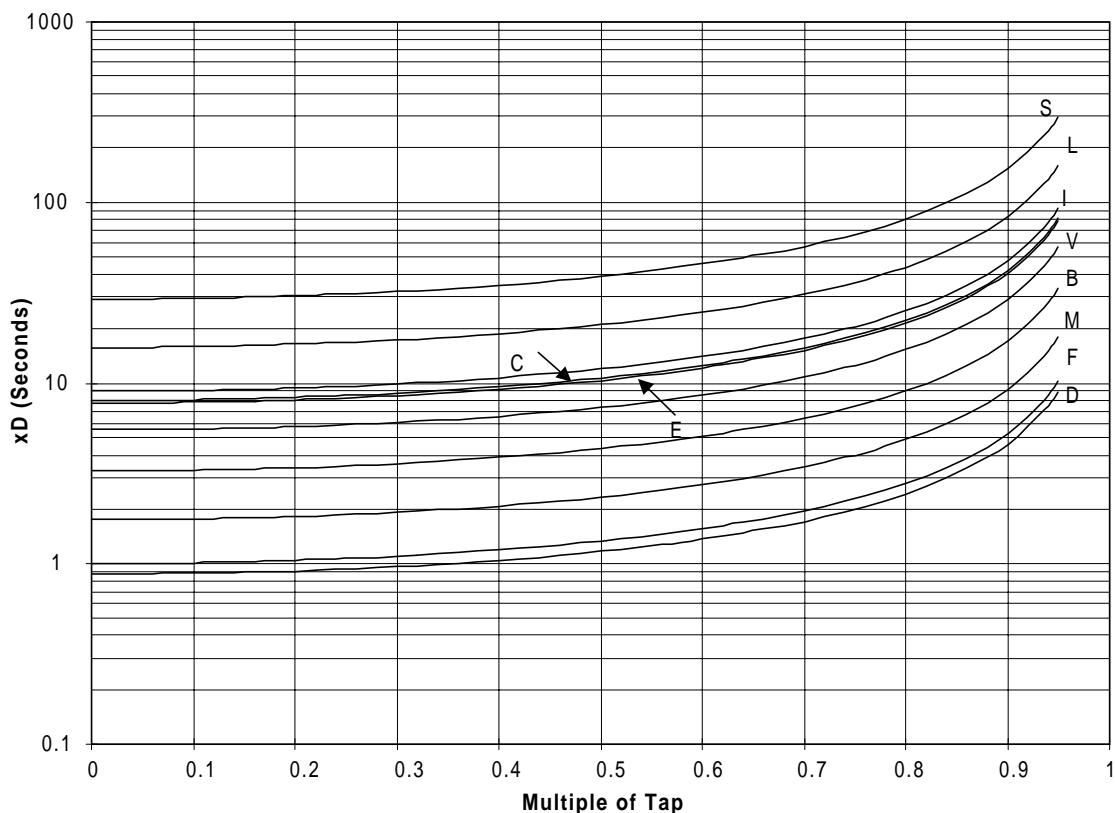

This chart vertical axis **x D (Seconds)** is applicable for all curves and is derived from multiplying the curve selected times **D** (the TIME DIAL setting).

Figure 1-6. Integrating Reset Characteristic Curve

50/51 Output

Output contacts are surge protected and rated as follows:

Resistive:

120/240 Vac

Make and carry 30 amperes for 0.2 seconds, carry 7 amperes for 2 minutes, 3 amperes continuously, and break 5 amperes.

125/250 Vdc

Make and carry 30 amperes for 0.2 seconds, carry 7 amperes for 2 minutes, 3 amperes continuously, and break 0.3 ampere.

Inductive:

120/240 Vac,

125/250 Vdc

Make and carry 30 amperes for 0.2 seconds, carry 7 amperes for 2 minutes, 3 amperes continuously, and break 0.3 ampere. 0.3 amperes. (L/R = 0.04).

AUX Output

Output contacts can be configured in the field using jumpers to select closing on either/or timed or instantaneous trip. Output contacts are surge protected and rated as follows:

Resistive:

120/240 Vac

Make 30 amperes for 0.2 seconds, carry 7 amperes continuously, and break 5 amperes.

125/250 Vdc

Make 30 amperes for 0.2 seconds, carry 7 amperes continuously, and break 0.3 ampere.

Inductive:

120/240 Vac,

125/250 Vdc

Make and carry 30 amperes for 0.2 seconds, carry 7 amperes continuously, and break 0.3 ampere. (L/R = 0.04).

BE1-50/51M-222 General Information

Isolation	Meets IEC 255-5 and exceeds IEEE C37.90-1989, one-minute dielectric (high potential) tests as follows: All circuits to ground: 2828 Vdc Input to Output Circuits 2000 Vac or 2828 Vdc
Surge Withstand Capability <i>Oscillatory</i>	Qualified to IEEE C37.90.1-1989 <i>Standard Surge Withstand Capability (SWC) Tests for Protective Relays and Relay Systems.</i>
<i>Fast Transient</i>	Qualified to IEEE C37.90.1-1989 <i>Standard Surge Withstand Capability (SWC) Tests for Protective Relays and Relay</i>
Fast Transient	Qualified to IEEE C37.90-1989.
Impulse Test	Qualified to IEC 255-5.
Radio Frequency Interference (RFI)	Field tested using a five watt, hand held transceiver operating at random frequencies centered around 144 megahertz and 440 megahertz, with the antenna located six inches from the relay in both horizontal and vertical planes.
Temperature	<u>Operating Range</u> -40°C (-40°F) to 70°C (158°F) <u>Recommended Storage Range</u> -50°C (-58°F) to 50°C (122°F).
Shock	15 g in each of three mutually perpendicular planes.
Vibration	2 g in each of three mutually perpendicular planes swept over the range of 10 to 500 hertz for a total of six sweeps, 15 minutes each sweep.
Case	C1.
Weight	8.6 pounds.

CHARACTERISTIC CURVES

Figures 1-7 through 1-15 illustrate the characteristic curves that are programmed into the nonvolatile memory of this relay. To order full-size drawings of these characteristic curves, contact the Customer Service Department of the Power Systems Group, Basler Electric, and request the 99-(4 digit) number associated with each graph. These graphs are full size characteristic curves on transparent paper (vellum).

BE1-50/51M-222 General Information

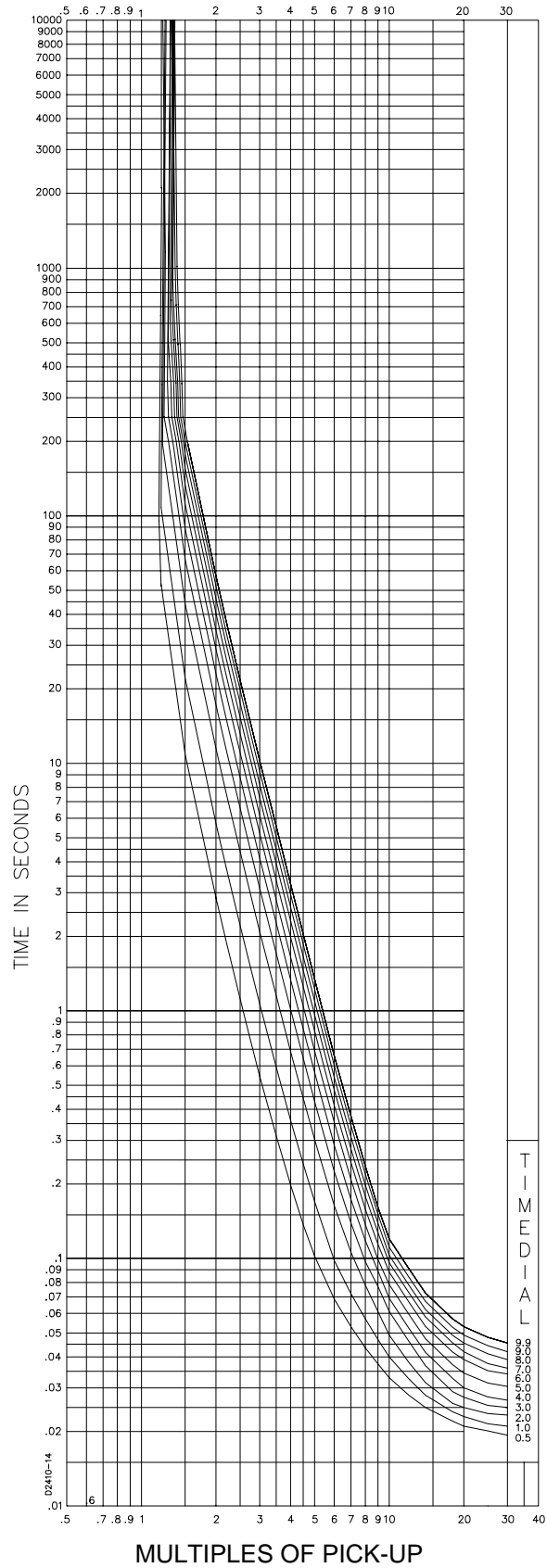

Figure 1-7. Time Characteristic Curve 99-1610, Load Demand Curve

BE1-50/51M-222 General Information

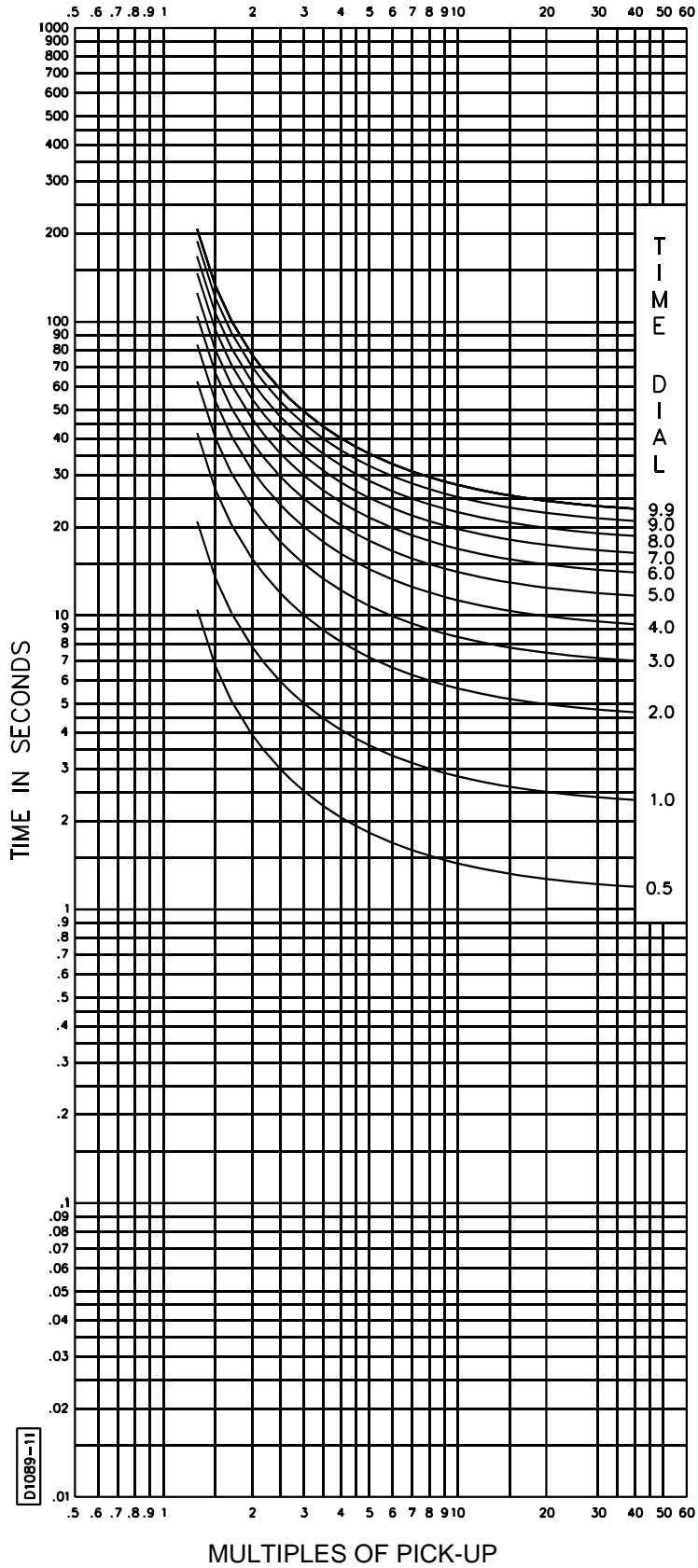

Figure 1-8. Time Characteristic Curve, 99-1370, L-Long Inverse

BE1-50/51M-222 General Information

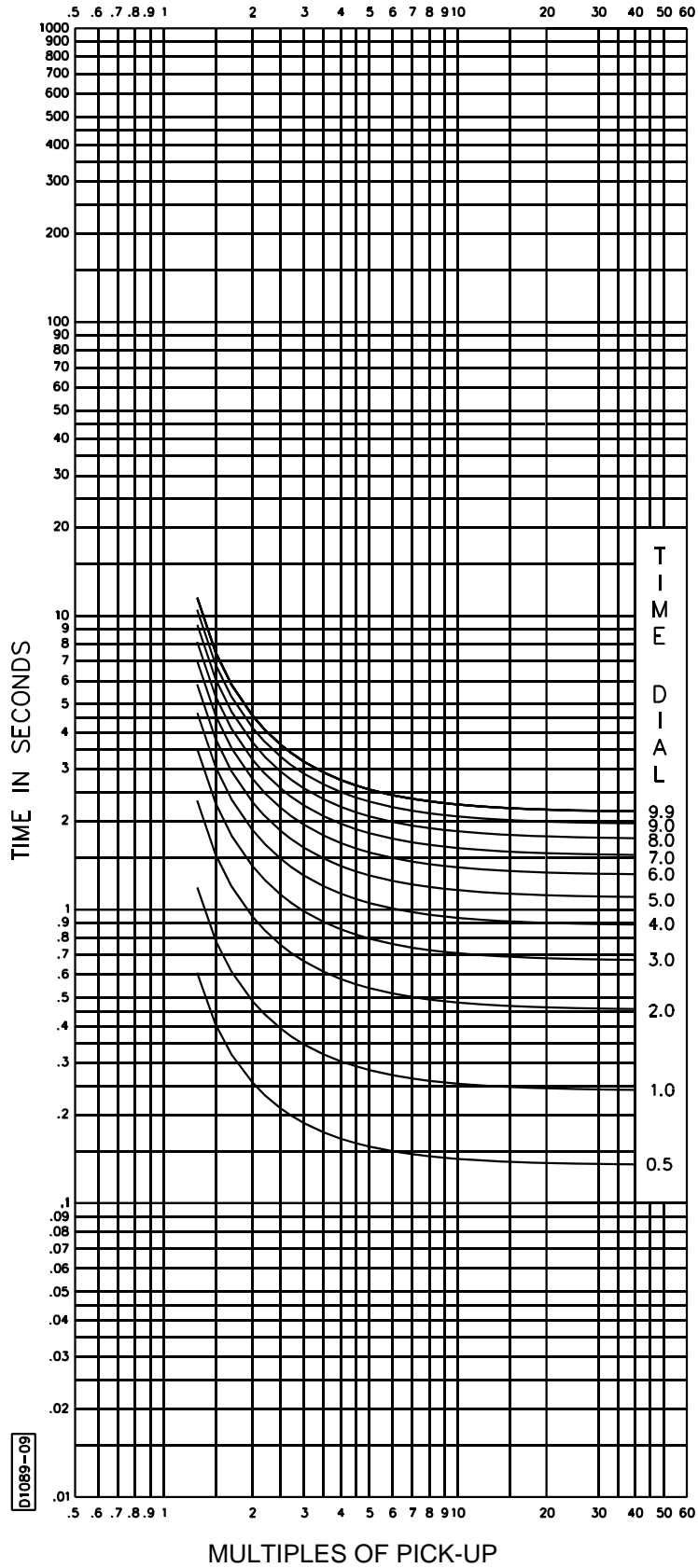

Figure 1-9. Time Characteristic Curve, 99-1371, D-Definite Time

BE1-50/51M-222 General Information

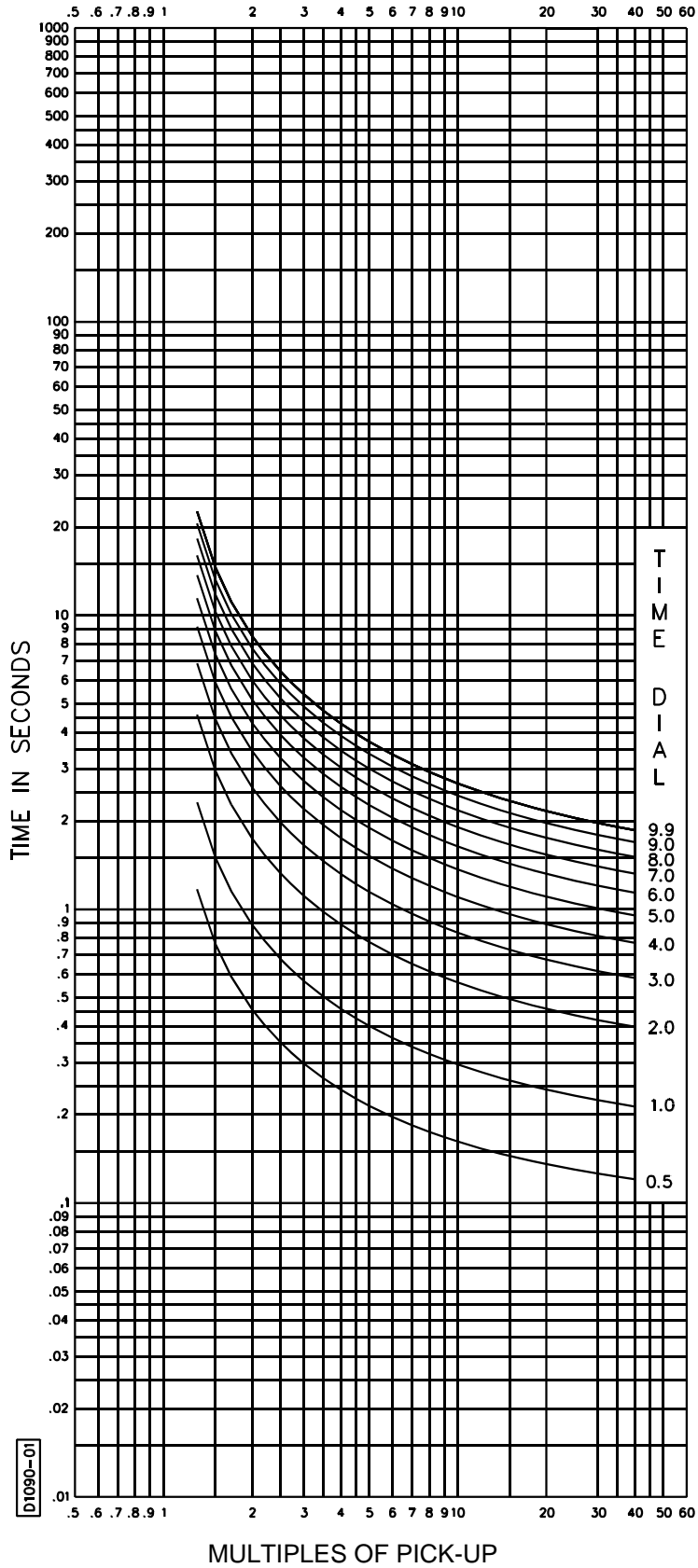

Figure 1-10. Time Characteristic Curve, 99-1372, M-Moderately Inverse

BE1-50/51M-222 General Information

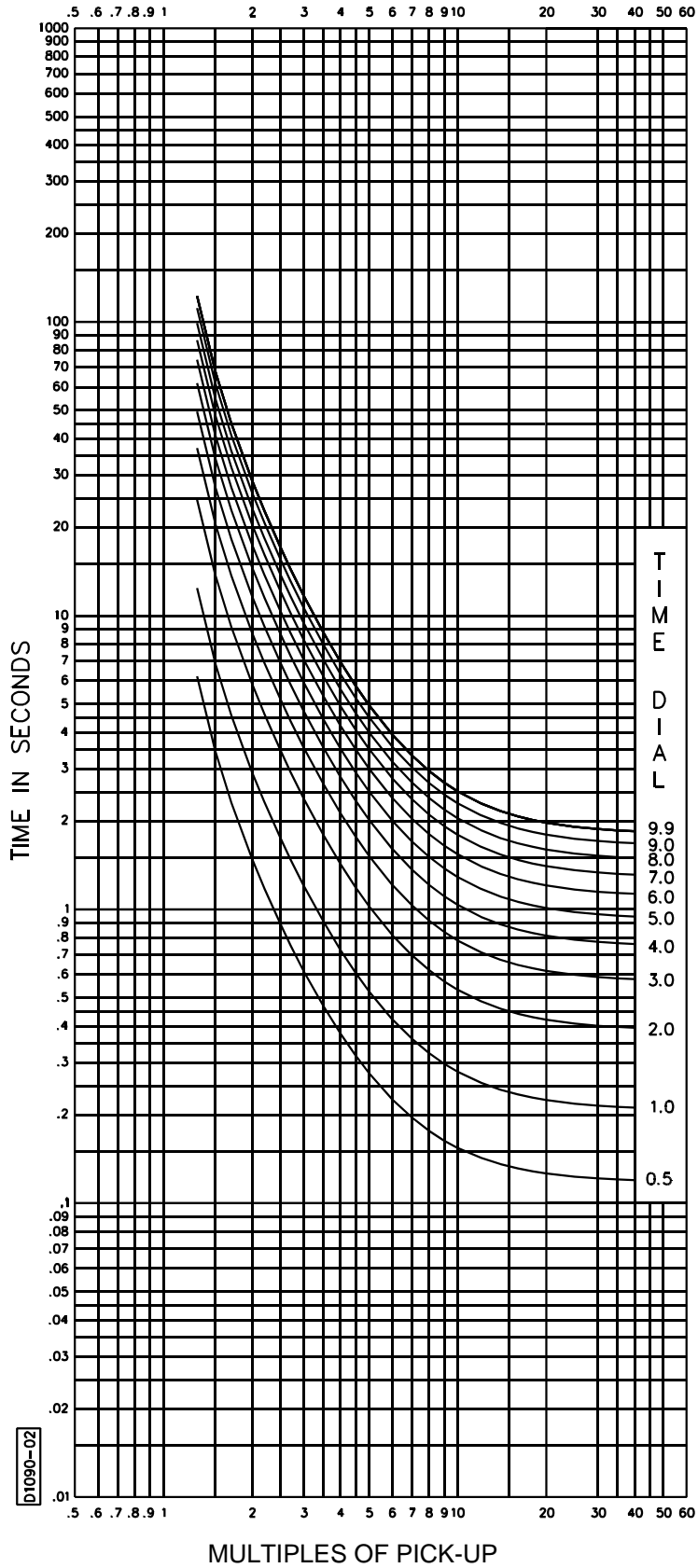

Figure 1-11. Time Characteristic Curve, I-Inverse

BE1-50/51M-222 General Information

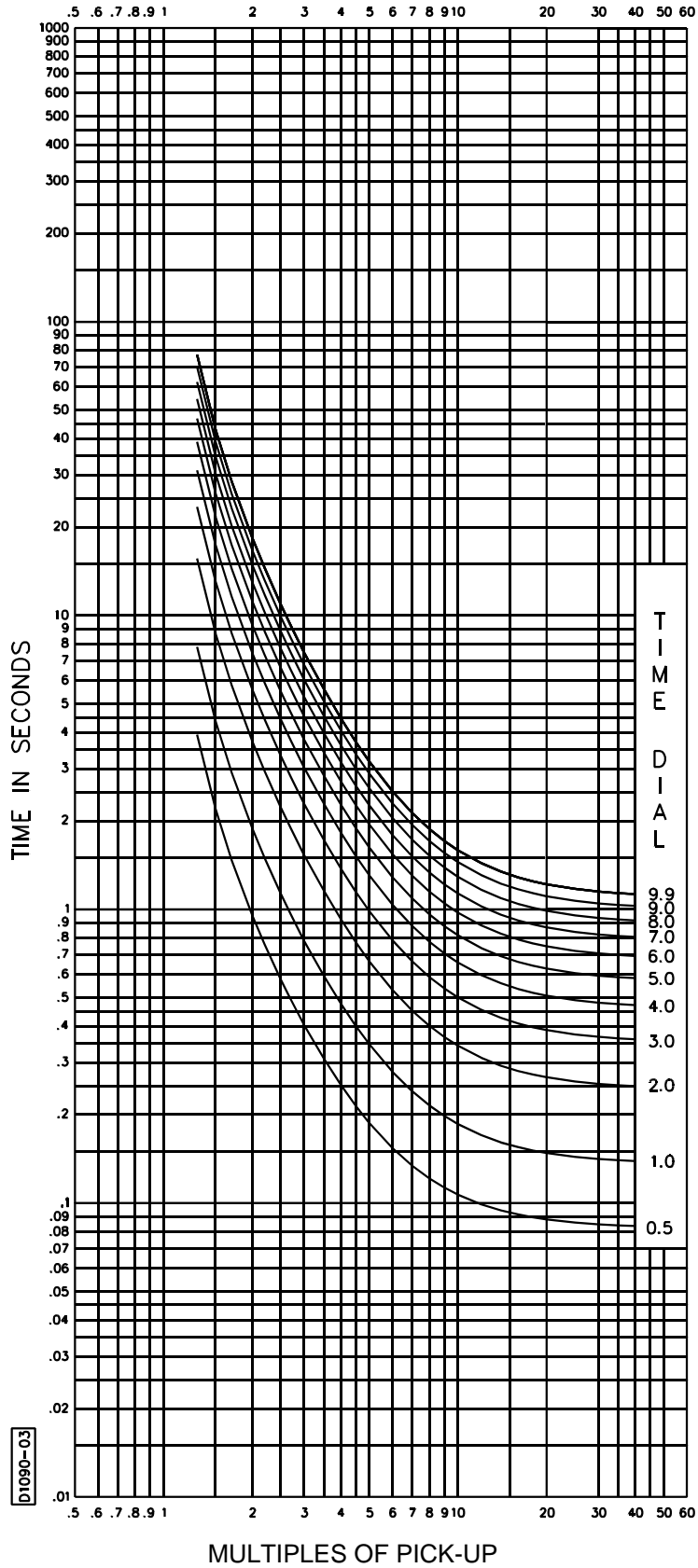

Figure 1-12. Time Characteristic Curve, 99-1374, V-Very Inverse

BE1-50/51M-222 General Information

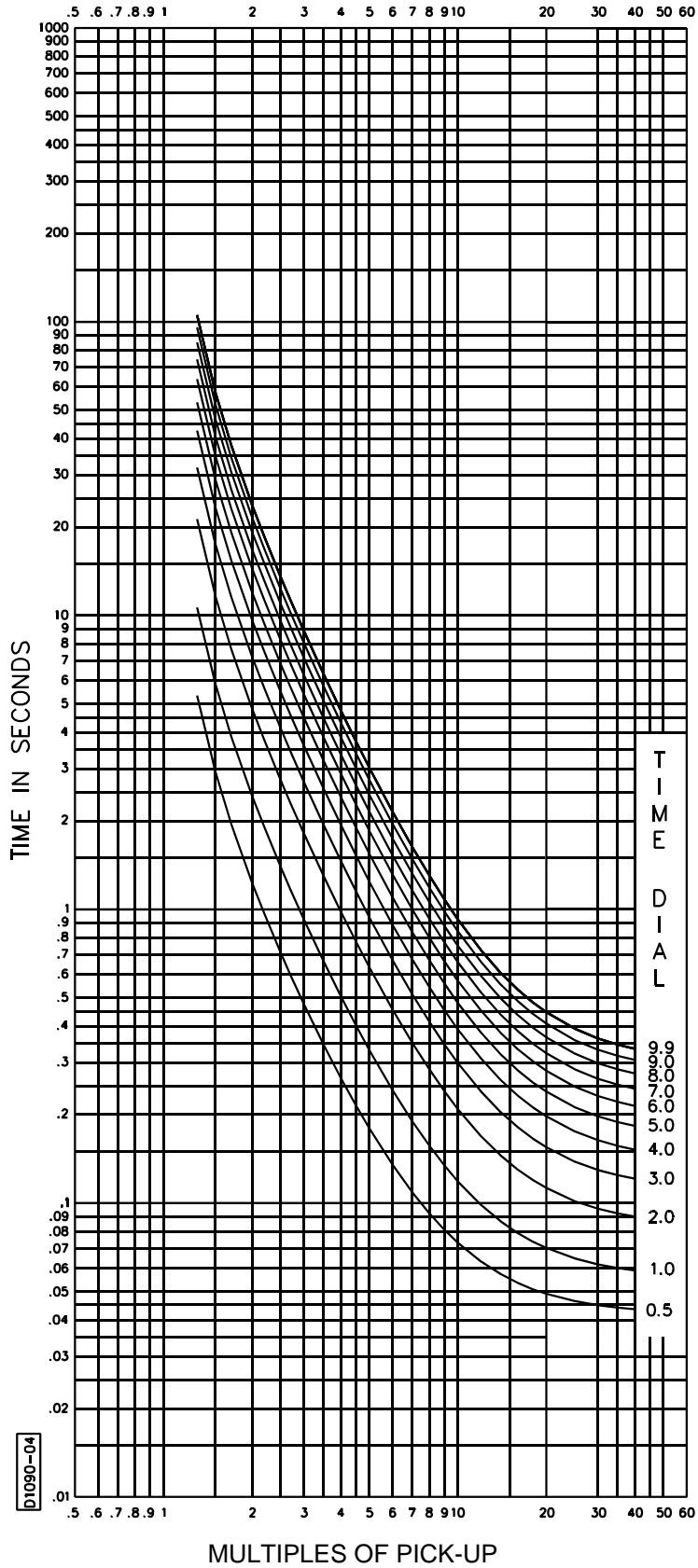

Figure 1-13. Time Characteristic Curve, 99-1375, E-Extremely Inverse

BE1-50/51M-222 General Information

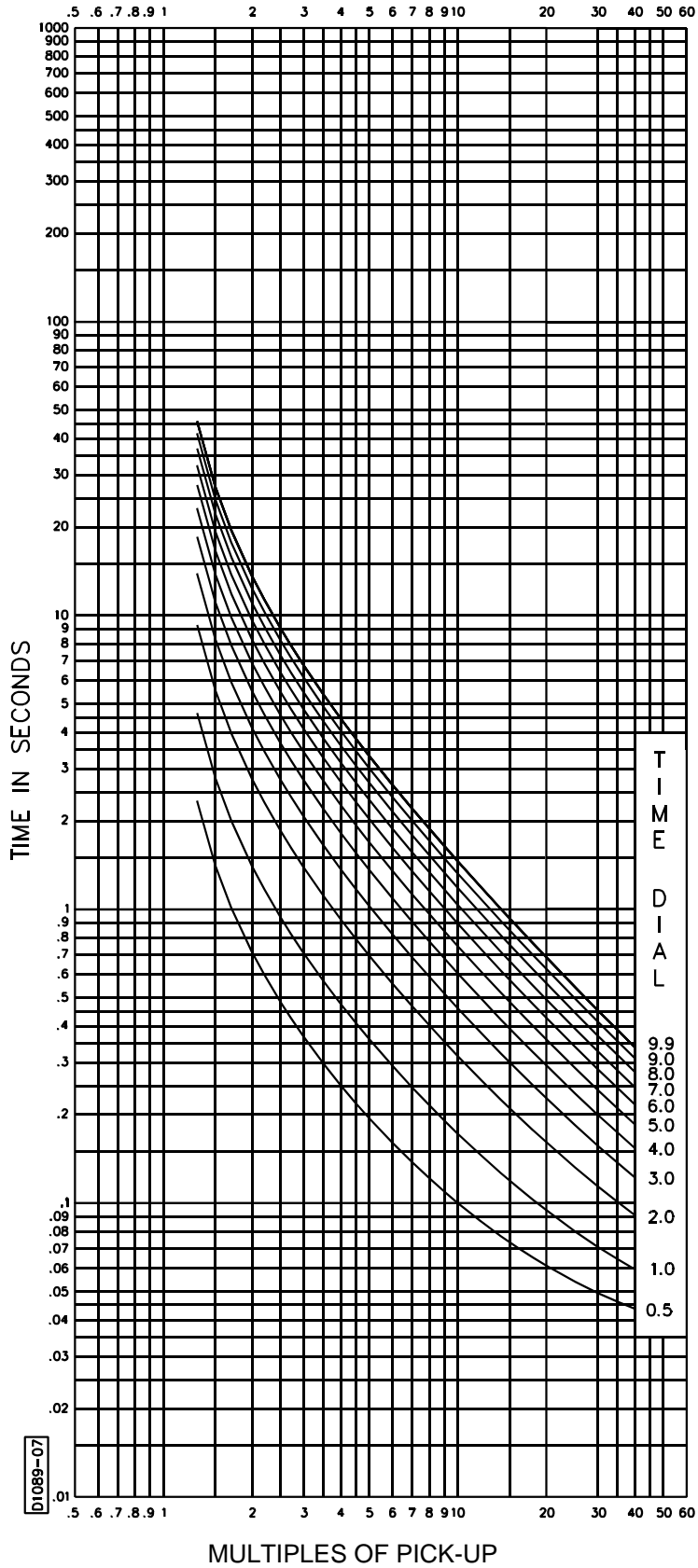

Figure 1-14. Time Characteristic Curve B, 99-1376, BS142-B

BE1-50/51M-222 General Information

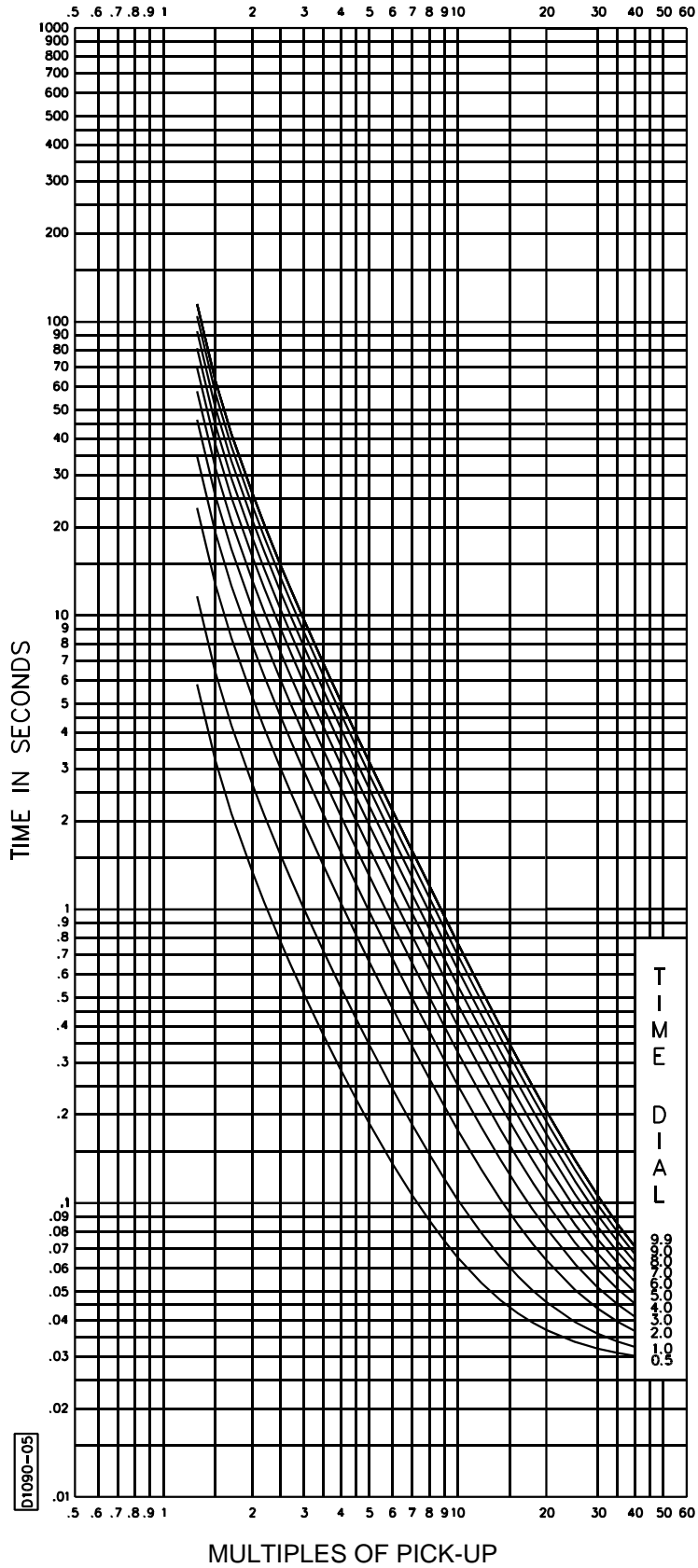

Figure 1-15. Time Characteristic Curve, 99-1377, BS142-C

SECTION 2

CONTROLS AND INDICATORS

GENERAL

Table 2-1 lists and briefly describes the BE1-50/51M-222 controls and indicators. Reference the callouts to Figures 2-1 and 2-2.

Table 2-1. BE1-50/51M-222 Controls and Indicators (Refer to Figures 2-1, 2-2, and 2-3)

Locator	Control or Indicator	Function
A	INST MANUAL TRIP Test Points	When shorted, the test points (jacks) provide a secure means to manually trip the controlled breaker. Jacks accept a standard 0.080 inch diameter phone tip plug.
B	INST PICKUP Selectors	Two switches to select pickup current in amperes (TENS and UNITS). Changing switch selectors while the relay is in service may cause tripping.
C	Targets	Black target indicators trip to red and magnetically latch when the trip circuit current is greater than 0.2 amperes. One target each for TIME and INST.
D	TIME PICKUP Selectors	Two switches to select pickup current in amperes (TENS and UNITS). Changing switch selectors while the relay is in service may cause tripping.
E	CURVE Selector	Ten position selector switch to select one of nine inverse functions or one fixed time function.
F	TIME DIAL Selectors	Two selector switches (TENS and UNITS) to select the desired characteristic curve. A setting of 0.0 results in instantaneous operation without any intentional delay. A setting of 9.9 corresponds to the typical time provided by an electromechanical relay at its maximum dial setting.
G	TIME MANUAL TRIP Test Points	When shorted, the test points provide a secure means to manually trip the controlled breaker. Jacks accept a standard 0.080 inch diameter phone tip plug.
H	PICKUP LED	Red LED indicates sensed current has exceeded the TIME PICKUP setting. LED turns OFF when sensed current falls below 95 % of pickup setting.
I	Target Reset Lever	Linkage extends through back of front cover to reset both magnetically latched target indicators.
J	SW8 -1 SW8-2 SW8-3	SW8-1 selects the system operating frequency. SW8-1 open (OFF) selects 60 hertz operation. SW8-1 closed (ON) selects 50 hertz operation. SW8-2 selects additional delay for the instantaneous element. Switch SW8-2 closed (ON) provides an additional instantaneous delay of 0.1 seconds. SW8-3 closed (ON) provides an additional instantaneous delay of 0.2 seconds. Closing both switches SW8-2 and -3 provides an additional instantaneous delay of 0.3 seconds.

BE1-50/51M-222 Controls and Indicators

Table 2-1. BE1-50/51M-222 Controls and Indicators - Continued

Locator	Control or Indicator	Function
J - Continued	SW8-4	Provides selection of either instantaneous or integrating reset characteristic. Closing SW8-4 provides integrating reset. Opening SW8-4 provides instantaneous reset.
K	Auxiliary Output Jumper Terminations	<p>Configures the auxiliary output contacts to close with either the instantaneous (50) trip and/or the timed (51) trip.</p> <p>Jumper E2 to E1A to close the auxiliary contact with the timed (51) trip. This jumper is yellow and factory installed to close the auxiliary output contacts with the timed trip.</p> <p>Jumper E3 to E1B to close the auxiliary contact with the instantaneous (50) trip. This jumper is blue and factory installed to close the auxiliary output contacts with the instantaneous trip.</p>

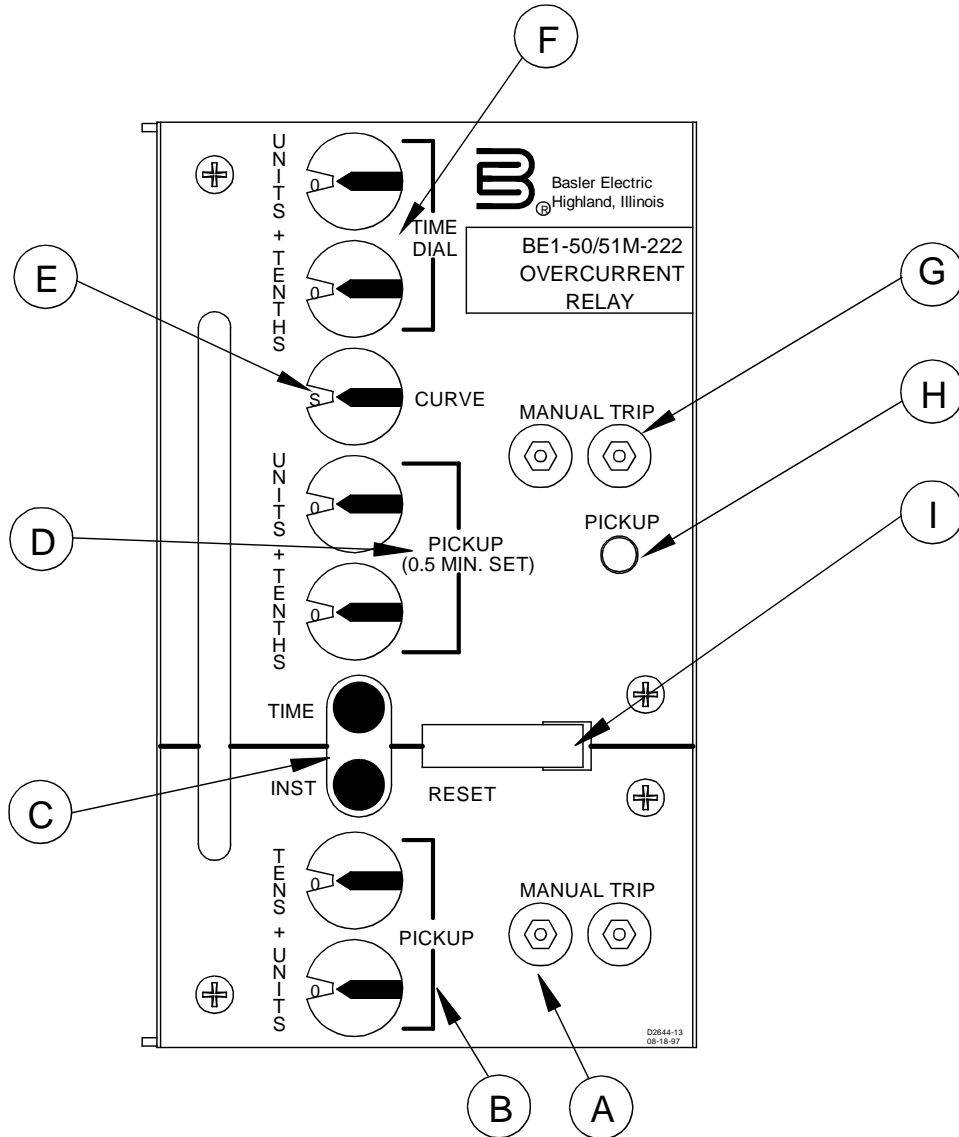
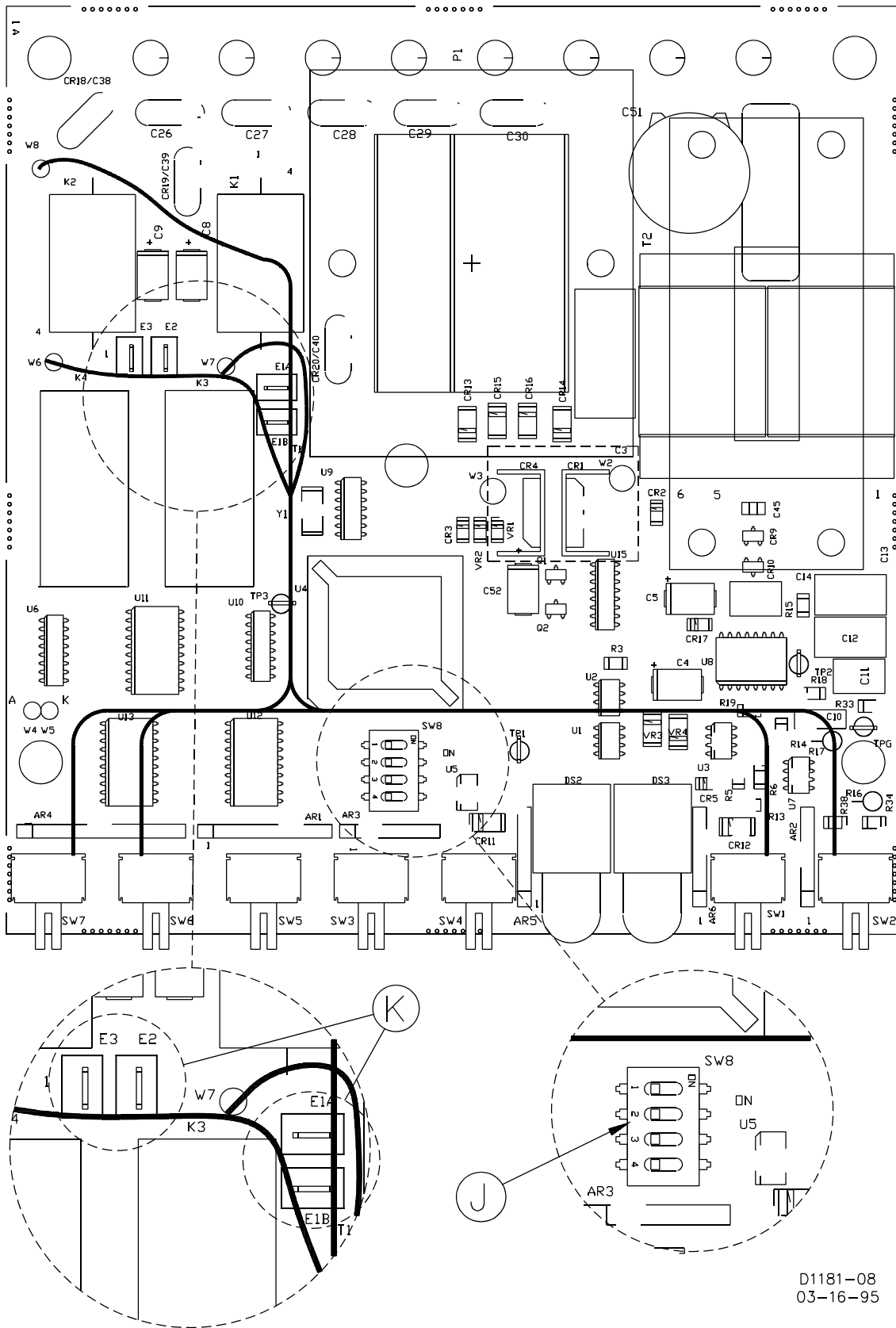

Figure 2-1. BE1-50/51M-222, Location of Controls and Indicators

BE1-50/51M-222 Controls and Indicators



D1181-08
03-16-95

Figure 2-2. BE1-50/51M-222, Location of Controls and Indicators

SECTION 3

FUNCTIONAL DESCRIPTION

GENERAL

BE1-50/51M-222 Overcurrent Relays are microprocessor based non-directional relays that measure ac current to provide secure and reliable instantaneous and time overcurrent protection for power systems.

FUNCTIONAL DESCRIPTION

Sensing Input

Single phase ac current from system current transformers (CT) is brought into the BE1-50/51M Overcurrent Relay at terminals eight and nine. Refer to Figure 3-1 to follow the functional description. The input current is applied to internal power and signal CTs.

Power Supply

Current from the power CT is rectified, filtered, and supplied to all of the internal circuitry for operating power. A precision +5 Vdc supply also serves as a reference for automatic calibration.

Instantaneous Signal

Current from the signal CT is rectified and applied to the instantaneous scaling resistors controlled by the INST PICKUP selector switches. The analog voltage of the instantaneous input signal developed across the scaling resistors is filtered and applied to the multiplexor (MUX).

Time Signal

Current from the signal CT is also rectified and applied to the time scaling resistors controlled by the TIME PICKUP selector switches. The analog voltage of the time input signal is also filtered and applied to the multiplexor.

Microprocessor

Operating power from the power supply is applied to the microprocessor supervisor circuit. When the input current falls below an acceptable level, the supervisor circuit interrupts the microprocessor and halts further operation. A microprocessor watchdog feature resets the microprocessor program when the program flow is interrupted.

Information from the TIME DIAL selector switches, the TIME CURVE selector switch, and the 50/60 Hz, INST DELAY, and RESET CHAR switches is also applied to the microprocessor. The microprocessor uses these inputs to set the operating parameters.

When the microprocessor is ready for analog information from the multiplexor, microprocessor control signals cause the multiplexor to route the desired input through to the output. The output is converted from an analog value to a digital value and applied to the microprocessor.

BE1-50/51M-222 Functional Description

The microprocessor performs the program operations based on the inputs and the internal software program. When the sensed current exceeds the TIME PICKUP setting, the TIME PICKUP LED is turned ON. TIME contacts (51 and 51 AUX) are closed in accordance with the time characteristic curve. If the sensed current exceeds the INST PICKUP setting, the INST contacts (50) are closed.

Power-Off Sensing

The power-off sensing circuits measure the decaying voltage to determine the length of time that power is removed (zero current). This provides information for the integrating reset function even when power has been entirely removed.

Outputs

Instantaneous And Timed

System circuit breakers controlled by the output contacts can be manually tripped by applying a short across the TIME or INST MANUAL TRIP front panel test points. Current flow in the trip circuit is indicated by the operation of the target. The targets will not operate without adequate operating power for the relay.

CAUTION

Trip circuit voltage is present at the front panel test points. When shorting the test points, use insulated jumpers to avoid contact with these voltages.

Auxiliary

The auxiliary output contacts can be configured by the user to close when the timed and/or instantaneous trip occurs. With both jumpers installed (this is the factory setting) either the timed or instantaneous trip closes the auxiliary contacts.

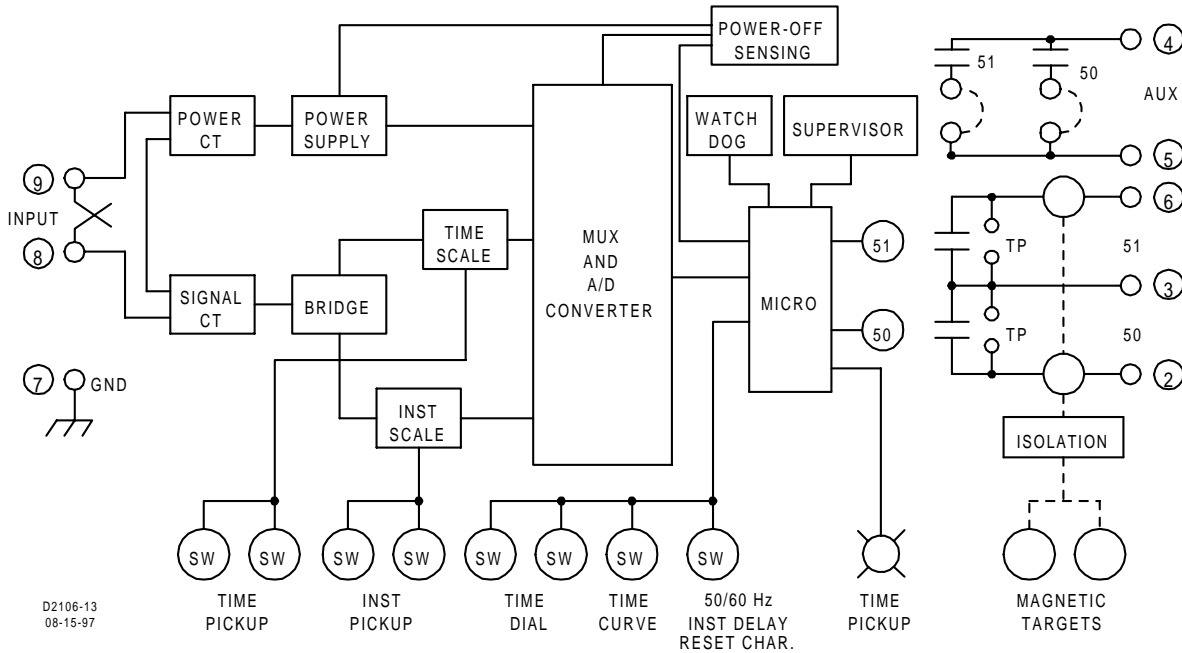

Figure 3-1. Functional Block Diagram

SECTION 4

INSTALLATION

GENERAL

When not shipped as part of a control or switchgear panel, the relays are shipped in sturdy cartons to prevent damage during transit. Immediately upon receipt of a relay, check the model and part number against the requisition and packing list to see that they agree. Visually inspect the relay for damage that may have occurred during shipment. If there is evidence of damage, immediately file a claim with the carrier and notify the Regional Sales Office, or contact the Sales Representative at Basler Electric, Highland, Illinois.

Proper operation of the relay may be confirmed by performing the operational test procedure in Section 5, *Testing*. In the event the relay is not to be installed immediately, store the relay in its original shipping carton in a moisture and dust free environment.

DIELECTRIC TEST

In accordance with IEC 255-5 and IEEE C37.90-1989, one-minute dielectric (high potential) tests may be performed as follows:

All circuits to ground:	2828 Vdc
Input to output circuits:	2000 Vac or 2828 Vdc

Output contacts are surge protected.

MOUNTING

Because the relay is of solid state design, it does not have to be mounted vertically. Any convenient mounting angle may be chosen. Relay outline dimensions and panel drilling diagrams are shown in Figures 4-1 and 4-2. Dimensions in parentheses are in millimeters. Horizontal or Vertical mount C1 cases have the same dimension.

BE1-50/51M-222 Installation

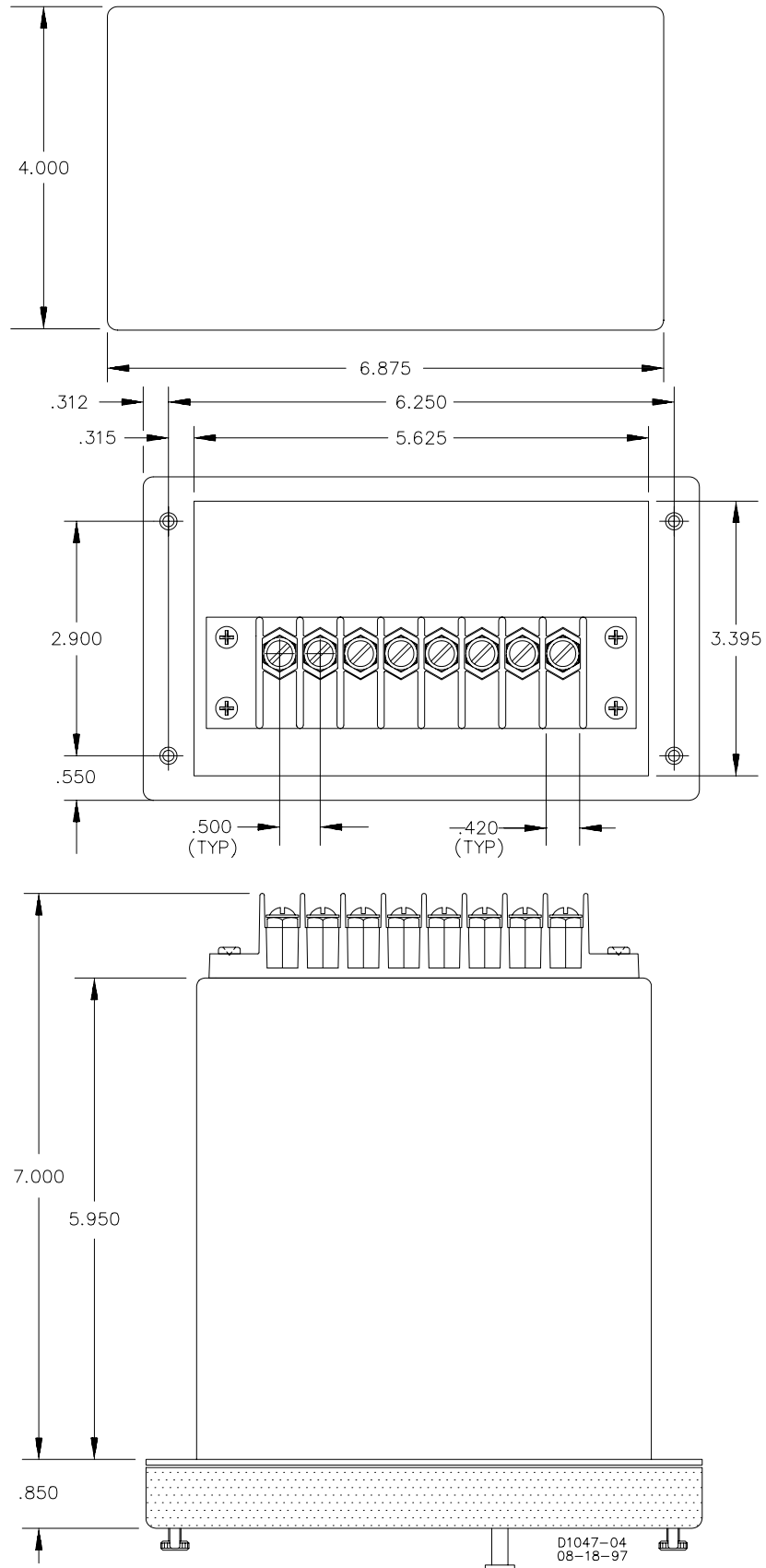

Figure 4-1. Outline Dimensions, C1 Case

BE1-50/51M-222 Installation

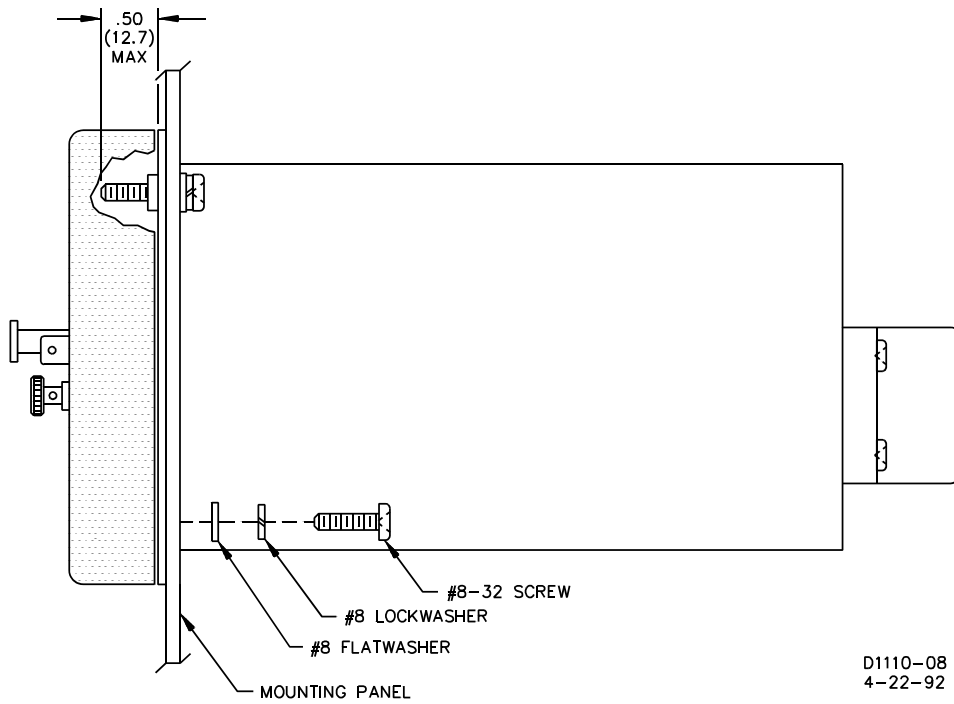
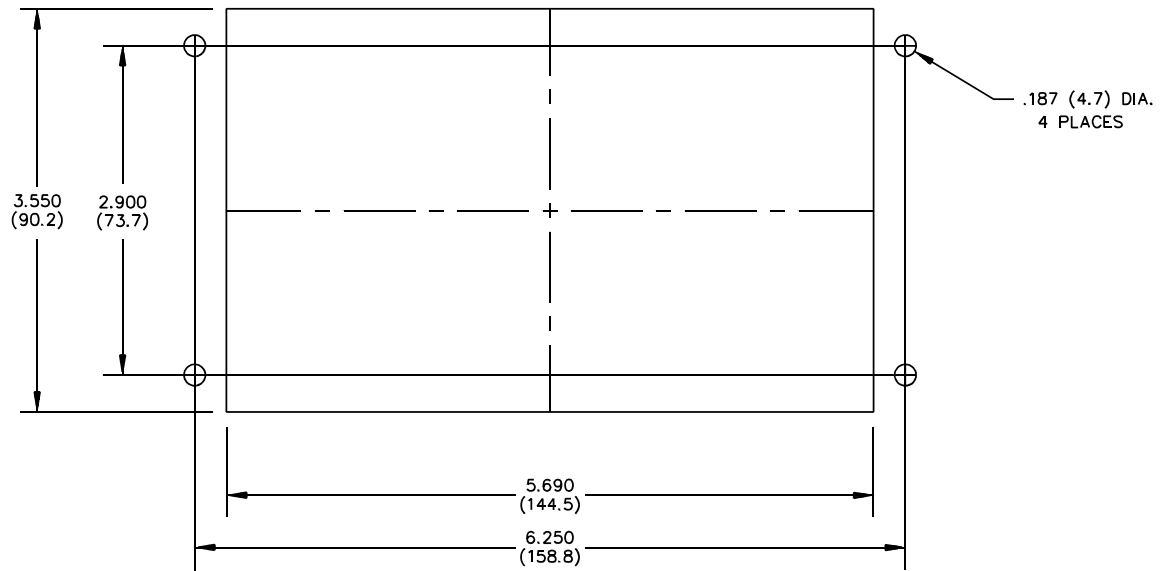

Figure 4-2. Panel Drilling Diagram, C1 Case

BE1-50/51M-222 Installation

CONNECTIONS

Incorrect wiring may result in damage to the relay. Be sure to check model and part number before connecting and energizing a particular relay.

NOTE

Be sure the ground terminal is hard-wired to the relay panel with no smaller than 12 AWG copper wire attached to the ground terminal on the rear of the terminal strip.

Connections should be made with minimum wire size of 14 AWG except as noted for the ground wire. Typical ac input and dc control connections are shown in Figures 4-3 and 4-4. The auxiliary output jumper configuration schematic diagram is also shown in Figure 4-4. Relay internal connections are shown on the back of the relay. Figure 4-5 shows a rear view of the relay and the connections.

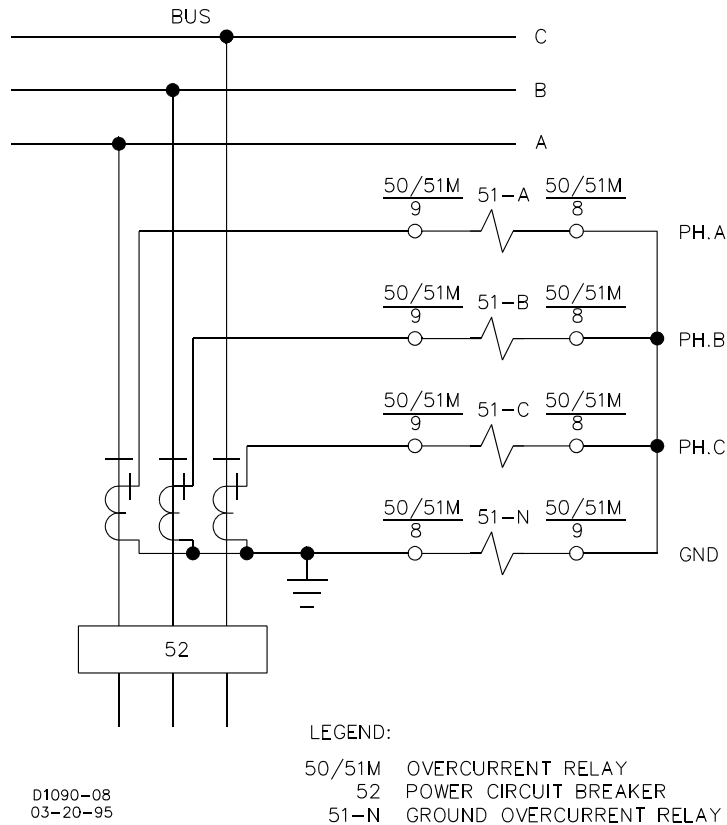

Figure 4-3. AC Input Connections

BE1-50/51M-222 Installation

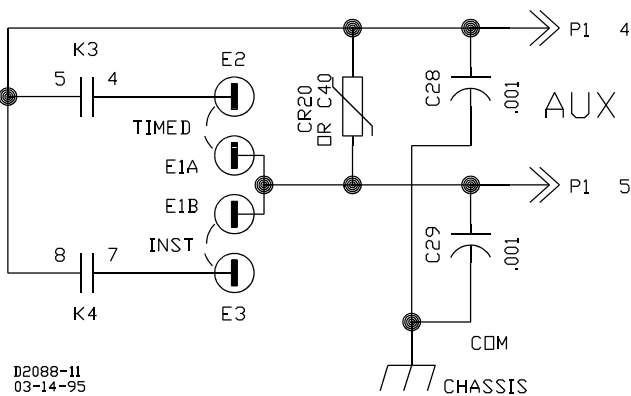
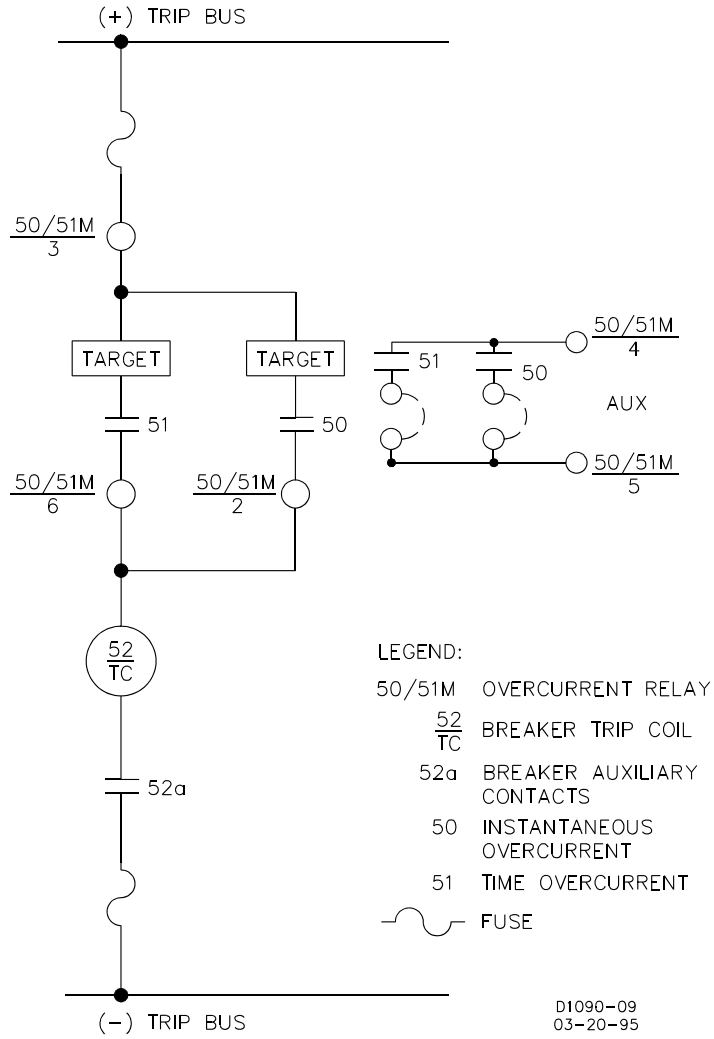

Figure 4-4. DC Control Connections

BE1-50/51M-222 Installation

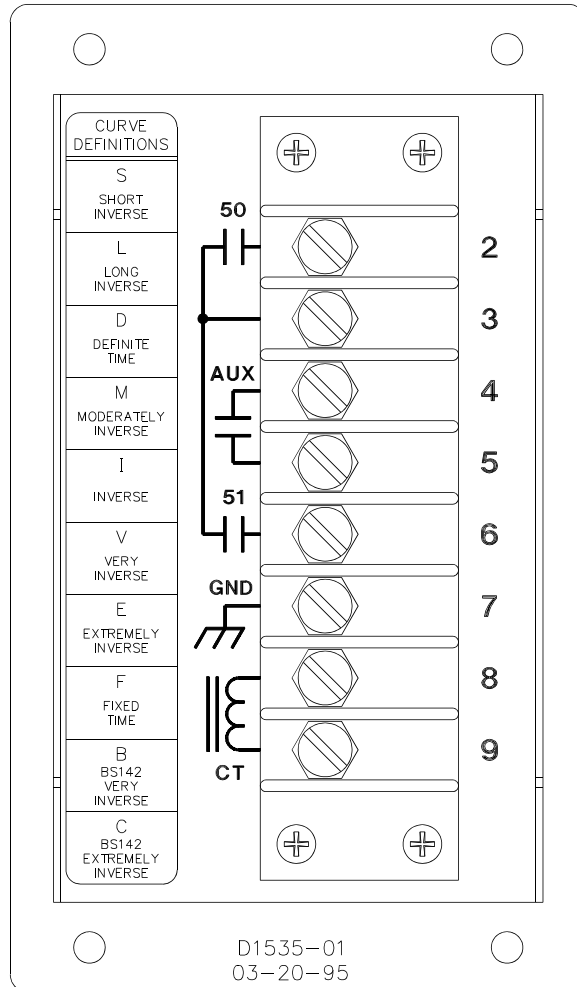

Figure 4-5. BE1-50/51M-222 Overcurrent Relay, Rear View

SECTION 5

TESTING

GENERAL

When not shipped as part of a control or switchgear panel, the relays are shipped in sturdy cartons to prevent damage during transit. Immediately upon receipt of a relay, check the model and part number against the requisition and packing list to see that they agree. Visually inspect the relay for damage that may have occurred during shipment. If there is evidence of damage, immediately file a claim with the carrier and notify the Regional Sales Office, or contact the Sales Representative at Basler Electric, Highland, Illinois.

Proper operation of the relay may be confirmed by performing the operational test procedures in this Section. In the event the relay is not to be installed immediately, store the relay in its original shipping carton in a moisture and dust free environment.

DIELECTRIC TEST

In accordance with IEC 255-5 and IEEE C37.90-1989, one-minute dielectric (high potential) tests may be performed as follows:

All circuits to ground:	2828 Vdc.
Input to output circuits:	2000 Vac or 2828 Vdc.

Output contacts are surge protected.

OPERATIONAL TEST PROCEDURE

The following procedure verifies operation of the relay. The test setup of Figures 5-1 and 5-2 are intended primarily as an illustration of the principles involved. Other test setups known to be capable of testing with the stated and implied tolerances (including equipment specifically designed for testing relays) may be used.

Test Equipment Required

- Current source with a range from 0 to 20 amperes ac (sensing input current).
- Current source 0.2 to 3 amperes, ac (target operation).
- Timer or counter.

CAUTION

When testing units with integrating reset characteristics selected, timing may be affected by the integrating reset.

BE1-50/51M-222 Testing

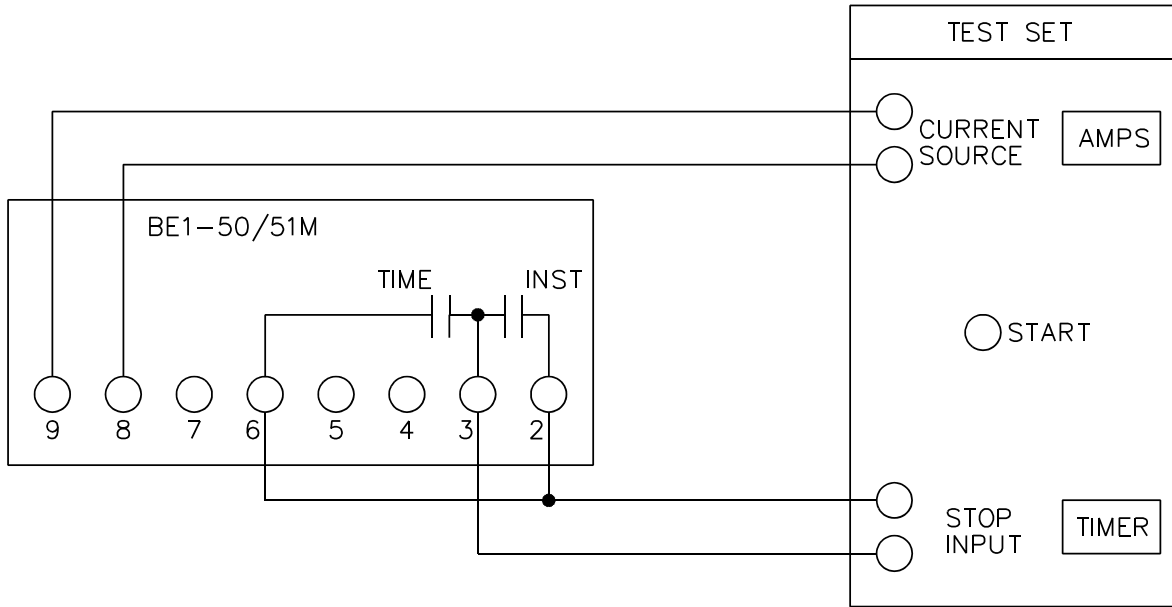

D1145-03
10-16-95

Figure 5-1. Pickup and Timing Test Setup

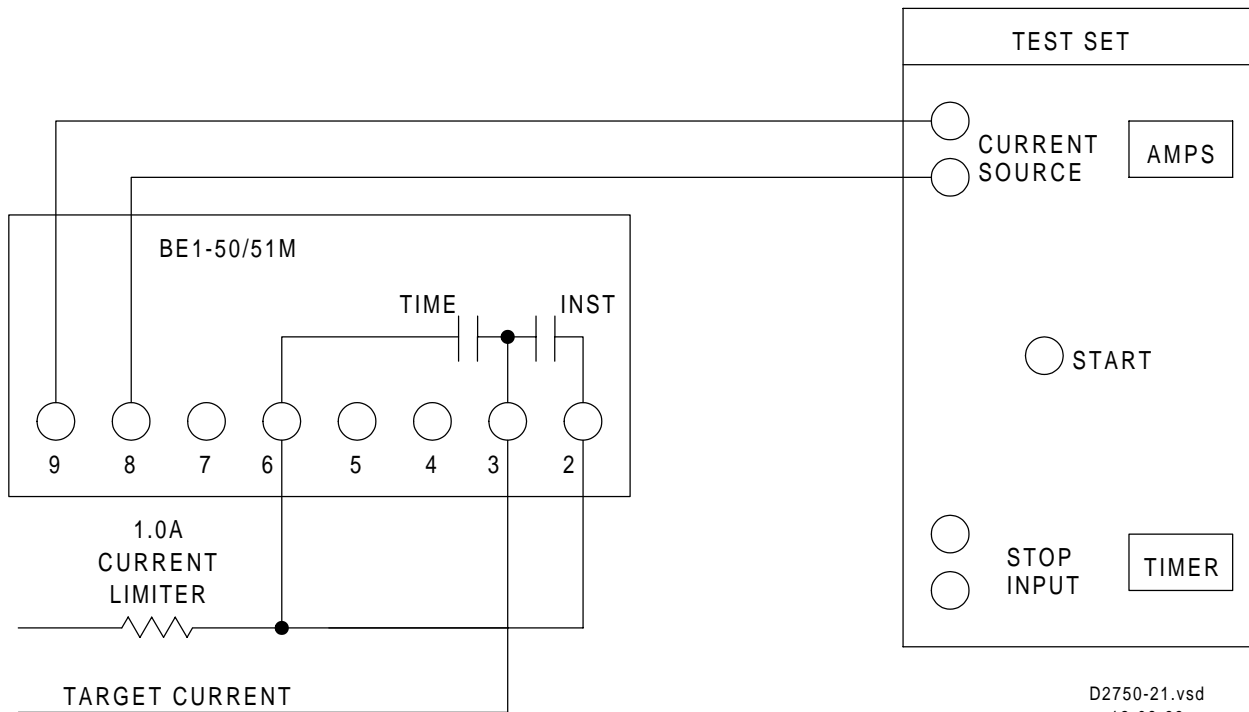

D2750-21.vsd
12-08-99

Figure 5-2. Target Operational Test Setup

BE1-50/51M-222 Testing

NOTES

When testing TIME overcurrent functions, INST PICKUP settings of 00 will affect the calibration of the TIME functions. TIME PICKUP settings of 00 also affect INST functions.

Test Procedure

Time Pickup Test

Perform preliminary setup:

- Connect test setup as shown in Figure 5-1.
- Insure that SW8 switches are set correctly: SW8-1 for operating frequency, SW8-2 to OFF (no instantaneous delay), SW8-3 to OFF (no instantaneous delay), and SW8-4 to OFF (selects instantaneous reset).
- Set TIME DIAL to 0.0.
- Set CURVE to S
- Set TIME PICKUP to 0.5.
- Set INST PICKUP to 90.

Step 1. Slowly increase current to terminals 8 and 9. PICKUP LED should turn ON at a maximum input current of 0.550 ampere.

Step 2. Decrease input current until PICKUP LED turns OFF.

Step 3. Set TIME PICKUP to 2.2.

Step 4. Slowly increase current to terminals 8 and 9. PICKUP LED should turn ON at an input current of 2.131 to 2.269 amperes.

Step 5. Decrease input current until PICKUP LED turns OFF.

INST Pickup Test

Perform preliminary setup:

- Connect test setup as shown in Figure 5-1.
- Insure that SW8 switches are set correctly: SW8-1 for operating frequency, SW8-2 to OFF (no instantaneous delay), SW8-3 to OFF (no instantaneous delay), and SW8-4 to OFF (selects instantaneous reset).
- Set TIME DIAL to 0.0.
- Set CURVE to S
- Set TIME PICKUP to 15.1.
- Set INST PICKUP to 01.

Step 1. Slowly increase current to terminals 8 and 9. INST contacts should close at an input current of 0.955 to 1.045 amperes.

Step 2. Decrease input current until INST output contacts open.

Step 3. Set INST PICKUP to 08.

BE1-50/51M-222 Testing

Step 4. Slowly increase current to terminals 8 and 9. INST contacts should close at an input current of 7.815 to 8.185 amperes.

Step 5. Decrease input current until INST output contacts open.

Time Dial Test

Perform preliminary setup:

- Connect test setup as shown in Figure 5-1.
- Insure that SW8 switches are set correctly: SW8-1 for operating frequency, SW8-2 to OFF (no instantaneous delay), SW8-3 to OFF (no instantaneous delay), and SW8-4 to OFF (selects instantaneous reset).
- Set TIME DIAL to 4.0.
- Set CURVE to S
- Set TIME PICKUP to 1.0.
- Set INST PICKUP to 90.

Step 1. Prepare to apply 1.5 amperes input current to terminals 8 and 9 and record the elapsed time from when current is applied until TIME output contacts close.

Step 2. Apply the current (step from 0 to 1.5 amperes) and record the elapsed time. Elapsed time should be 72.49 to 99.38 seconds. (This tolerance is greater than $\pm 2\%$ because it is the accumulation of both pickup and timing tolerances.)

Step 3. Remove input current.

Target Test

Perform preliminary setup:

- Connect test setup as shown in Figure 5-2.
- Insure that SW8 switches are set correctly: SW8-1 for operating frequency, SW8-2 to OFF (no instantaneous delay), SW8-3 to OFF (no instantaneous delay), and SW8-4 to OFF (selects instantaneous reset).
- Set TIME DIAL to 4.5.
- Set CURVE to S
- Set TIME PICKUP to 1.0.
- Set INST PICKUP to 01.

Step 1. Set target current source to 1.0 ampere, ac.

Step 2. Apply 5 amperes input current to terminals 8 and 9. Check that both TIME and INST targets operate.

Step 3. Remove input current and reset targets.

BE1-50/51M-222 Testing

Manual Trip Test

Perform preliminary setup:

- Connect test setup as shown in Figure 5-2.
- Insure that SW8 switches are set correctly: SW8-1 for operating frequency, SW8-2 to OFF (no instantaneous delay), SW8-3 to OFF (no instantaneous delay), and SW8-4 to OFF (selects instantaneous reset).
- Set TIME DIAL to 4.5.
- Set CURVE to S
- Set TIME PICKUP to 1.0.
- Set INST PICKUP to 01.

CAUTION

Trip circuit voltage is present at the front panel test points. When shorting the test points, use insulated jumpers to avoid contact with these voltages.

Step 1. Set target current source to 1.0 ampere, ac.

Step 2. Apply 0.9 ampere input current to terminals 8 and 9.

Step 3. Connect a jumper between TIME MANUAL TRIP test points. Check that TIME target operates.

Step 4. Connect a jumper between INST MANUAL TRIP test points. Check that INST target operates.

Step 5. Reset targets.

Integrating Reset Test

Perform preliminary setup:

- Insure that SW8 switches are set correctly: SW8-1 for operating frequency, SW8-2 to OFF (no instantaneous delay), SW8-3 to OFF (no instantaneous delay), and **SW8-4 to ON** (selects integrating reset).
 - Set TIME DIAL to 4.5.
 - Set CURVE to I.
 - Set TIME PICKUP to 1.0.
 - Set INST PICKUP to 90.

Step 1. Set target current source to 1.0 ampere, ac.

Step 2. Read all of Step 3 before beginning Step 3.

Step 3. Apply 4.0 amperes input current to terminals 8 and 9. After the unit trips, remove the input current for 20 ± 0.25 seconds, then reapply the 4.0 amperes input current. Record the elapsed time from the reapplication of input current to the output retrip.

Result: Elapsed time should be 1.55 ± 0.3 seconds.

SETTING THE RELAY

Select the desired relay settings before putting the relay into service. Changing pickup current settings while the relay is in service may cause tripping.

PERIODIC TESTS

General

All relays should be tested periodically to identify and correct any problems that are found.

Single phase relays such as the BE1-50/51M-222 are normally used in groups of four (three phase and ground) on the protected circuit. Only three are required at any one time to provide complete protection. The fourth one assures that protection is maintained even if one relay failed.

This protection scheme also allows one unit at a time to be withdrawn for testing purposes without losing protection during the test. Refer to Figures 5-1 and 5-2 for recommended test setups.

Periodic Test

Periodic testing should consist of the following procedures.

- Step 1. Verify that the instantaneous pickup is within $\pm 2\%$ of the value set on the dials. Pickup occurs when the INST output contacts close.
- Step 2. Verify that the time pickup is within $\pm 2\%$ of the value set on the dials. Pickup occurs when the LED turns ON.
- Step 3. Verify that the time to trip for the curve and time dial settings at a multiple of six is the same as the time given on the characteristic curve. Refer to Section 1 for the characteristics curves.
- Step 4. Verify that the time to trip for the instantaneous element at a pickup multiple of 2 is not greater than the time given on the instantaneous characteristic curve. Refer to Section 1 for the instantaneous characteristic curve.
- Step 5. Verify that the 51 AUX contacts close when the time overcurrent element trips.
- Step 6. Verify that the targets operate with one ac ampere of trip current in the trip circuits and that they can be reset using the RESET LEVER.

This completes the periodic test.

SECTION 6

MAINTENANCE

GENERAL

BE1-50/51M-222 Overcurrent Relays require no preventive maintenance. However, periodic checks should be performed according to scheduled practices. A recommended periodic test is provided in this Section. If the relay fails to function properly and factory repair is desired, contact the Customer Service Department of the Power Systems Group, Basler Electric, for a return authorization number prior to shipping.

IN-HOUSE REPAIR

In-house replacement of individual components should be performed by qualified technicians.

CAUTION

Substitution of printed circuit boards or individual components does not necessarily mean the relay will operate properly. Always test the relay before placing it in operation.

Replacement parts may be purchased locally. The quality of replacement parts must be at least equal to that of the original components. These parts may be ordered directly from Basler Electric. Where special components are involved, contact the Customer Service Department of the Power Systems Group, Basler Electric. When complete boards or assemblies are needed, the following information is required.

1. Relay model number
2. Relay serial number

STORAGE

This protective relay contains long life aluminum electrolytic capacitors. Life in excess of 20 years may be expected if the storage temperature does not exceed 40°C (72°F).

PERIODIC TESTS

General

All relays should be tested periodically to identify and correct any problems that are found.

Single phase relays such as the BE1-50/51M-222 are normally used in groups of four (three phase and ground) on the protected circuit. Only three are required at any one time to provide complete protection. The fourth one assures that protection is maintained even if one relay failed.

This protection scheme also allows one unit at a time to be withdrawn from service for testing purposes without losing protection during the test. Refer to Section 5 for recommended test setups.

BE1-50/51M-222 Maintenance

Periodic Test

Periodic testing should consist of the following procedures.

- Step 1. Verify that the instantaneous pickup is within $\pm 2\%$ of the value set on the dials. Pickup occurs when the INST output contacts close.
- Step 2. Verify that the time pickup is within $\pm 2\%$ of the value set on the dials. Pickup occurs when the LED turns ON.
- Step 3. Verify that the time to trip for the curve and time dial settings at a multiple of six is the same as the time given on the characteristic curve. Refer to Section 1 for the characteristics curves.
- Step 4. Verify that the time to trip for the instantaneous element at a pickup multiple of 2 is not greater than the time given on the instantaneous characteristic curve. Refer to Section 1 for the instantaneous characteristic curve.
- Step 5. Verify that the 51 AUX contacts close when the time overcurrent element trips.
- Step 6. Verify that the targets operate with one ac ampere of trip current in the trip circuits and that they can be reset using the RESET LEVER.

This completes the periodic test.

SECTION 7

MANUAL CHANGE INFORMATION

SUMMARY AND CROSS REFERENCE GUIDE

This section contains information concerning the previous editions of the manual. The substantive changes to date are summarized in the Table 7-1.

Table 7-1. Changes

Revision	Summary of Changes	ECO/Date
A	Changed all references to the current for testing the targets to an ac only type of current. <i>Added Section 7, Manual Change Information.</i>	7480/12-20-99