

**SEL-251D-1  
DISTRIBUTION RELAY**

**PHASE OVERCURRENT RELAY  
GROUND OVERCURRENT RELAY  
MULTIPLE SHOT RECLOSING RELAY  
SELECTABLE SETTING GROUPS  
CIRCUIT BREAKER MONITOR  
FAULT LOCATOR  
SELogic<sup>®</sup> CONTROL EQUATIONS**

**INSTRUCTION MANUAL**

SCHWEITZER ENGINEERING LABORATORIES, INC.  
2350 NE HOPKINS COURT  
PULLMAN, WA USA 99163-5603  
TEL: (509) 332-1890 FAX: (509) 332-7990

The software (firmware), schematic drawings, relay commands, and relay messages are copyright protected by the United States Copyright Law and International Treaty provisions. All rights are reserved.

You may not copy, alter, disassemble, or reverse-engineer the software. You may not provide the software to any third party.

All brand or product names appearing in this document are the trademark or registered trademark of their respective holders.

Schweitzer Engineering Laboratories, SELogic, Connectorized, Job Done, SEL-PROFILE, SEL-5030 ACCELERATOR, and **SEL** are registered trademarks of Schweitzer Engineering Laboratories, Inc.

The English language manual is the only approved SEL manual.

Copyright © SEL 1992, 1993, 1994, 1995, 1996, 1997, 2002 (All rights reserved) Printed in USA.

This product is covered by U.S. Patent Numbers: 5,041,737; 5,447,408; 5,479,315; 5,602,707; and U.S. Patent(s) Pending, and Foreign Patent(s) Issued and Pending.

This product is covered by the standard SEL 10-year warranty. For warranty details, visit [www.selinc.com](http://www.selinc.com) or contact your customer service representative.

PM251D-01



This device is shipped with default passwords. Default passwords should be changed to private passwords at installation. Failure to change each default password to a private password may allow unauthorized access. SEL shall not be responsible for any damage resulting from unauthorized access.



Cet équipement est expédié avec des mots de passe par défaut. A l'installation, les mots de passe par défaut devront être changés pour des mots de passe confidentiels. Dans le cas contraire, un accès non-autorisé à l'équipement pourrait être possible. SEL décline toute responsabilité pour tout dommage résultant de cet accès non-autorisé.



## **SECTION 1: SEL-200 SERIES RELAY ADDENDUM**

---

The SEL-200 series relays with 125 Vdc optical isolator inputs now have level-sensitive inputs. These inputs compare to the original SEL-200 series relays as follows:

### **ORIGINAL SEL-200 SERIES OPTICAL ISOLATOR LOGIC INPUT RATING**

125 Vdc: 80 - 150 Vdc; 4 milliamps at nominal voltage

### **NEW SEL-200 SERIES OPTICAL ISOLATOR LOGIC INPUT RATING**

125 Vdc: 100 - 150 Vdc; 6 milliamps at nominal voltage

The optical isolator input does not assert for applied voltages less than 75 Vdc. The firmware remains unchanged.



# **SEL RELAY INSTRUCTION MANUAL ADDENDUM**

---

## **JUMPER INSTALLATION INSTRUCTIONS FOR ALL 200-SERIES RELAYS EXCEPT SEL-279 AND SEL-279H**

The power available from these ports is limited and should be used only for SEL-RDs, SEL-DTAs, dc-powered modems, or other low-wattage devices approved by SEL.

The power is available on either Port 1 or Port 2R. Port 2F, located on the front of the relay, does NOT have power available.

To install jumpers for supplying power through the rear EIA RS-232-C ports on all SEL-200 series relays (except SEL-279 and SEL-279H Relays), perform the following steps:

1. Remove the relay top cover or withdraw the main circuit board.
2. Locate jumpers JMP12 (+5 Vdc), JMP13 (+12 Vdc) and JMP14 (-12 Vdc) near the AUX INPUT connector.
3. Remove and install the needed jumpers in the "on" position.
4. Replace the top cover or re-insert the main circuit board. (Ensure that the board is correctly seated and the cables to the power supply and input transformers are reconnected.)





# **SEL-200 SERIES (SHALLOW) RELAY HARDWARE ADDENDUM**

---

The shallow SEL-200 series hardware brings a reduction in unit depth and weight. It compares to the original SEL-200 series relay hardware as follows:

## **ORIGINAL SEL-200 SERIES RELAY HARDWARE SPECIFICATIONS**

3.47" x 19.00" x 11.66" (8.81 cm x 48.26 cm x 29.62 cm) (H x W x D)

16 pounds (7.3 kg)

## **SEL-200 SERIES (SHALLOW) RELAY HARDWARE SPECIFICATIONS**

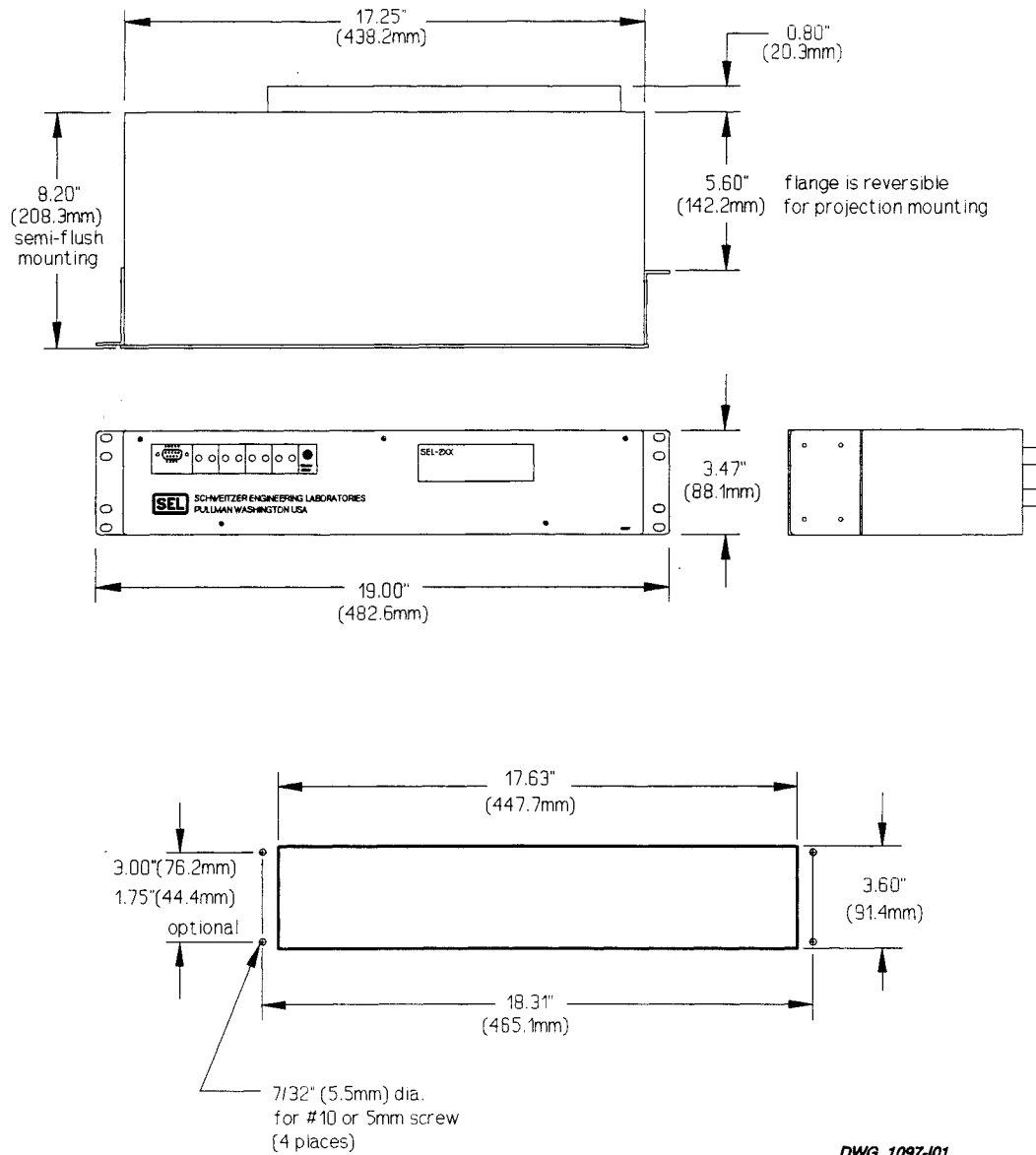
3.47" x 19.00" x 9.00" (8.81 cm x 48.26 cm x 22.86 cm) (H x W x D)

12 pounds (5.5 kg)

Depth (dimension D) is to the end of the rear panel terminal blocks.

This hardware is also equipped for low-level testing. The firmware remains unchanged.

All other specifications remain the same. The shallow SEL-200 series relay dimensions, panel cutout, and drill diagrams are on the following page.



DWG. 1097-101

### SEL-200 Series (Shallow) Relay Dimensions, Panel Cutout, and Drill Diagrams

# MANUAL CHANGE INFORMATION

---

The date code at the bottom of each page of this manual reflects the creation or revision date. Date codes are changed only on pages that have been revised and any following pages affected by the revisions (i.e., pagination). If significant revisions are made to a section, the date code on all pages of the section will be changed to reflect the revision date.

Each time revisions are made, both the main table of contents and the affected individual section table of contents are regenerated and the date code is changed to reflect the revision date.

Changes in this manual to date are summarized below (most recent revisions listed at top).

<b>Revision Date</b>	<b>Summary of Revisions</b>
The <i>Manual Change Information</i> section has been created to begin a record of revisions to this manual. All changes will be recorded in this Summary of Revisions table.	
20020212	This revision includes the following changes: <ul style="list-style-type: none"><li>- Replaced Standard Product Warranty page with warranty statement on cover page.</li></ul> <b>Appendix A:</b> <ul style="list-style-type: none"><li>- Updated Firmware Version information</li></ul>
970421	This revision includes the following changes: <b>Appendix A:</b> <ul style="list-style-type: none"><li>- Added New Firmware Versions</li></ul>



# TABLE OF CONTENTS

## INTRODUCTION

---

Getting Started . . . . .	1-1
Overview . . . . .	1-1
General Description . . . . .	1-2

## SPECIFICATIONS

---

General Specifications . . . . .	2-1
Functional Specifications . . . . .	2-3
SEL-251D-1 Relay SELOGIC Control Equations . . . . .	2-7
Targets . . . . .	2-13
Multiple Shot Reclosing Relay . . . . .	2-14
Selectable Setting Groups . . . . .	2-17
Circuit Breaker Monitor . . . . .	2-18
Metering . . . . .	2-18
Serial Interfaces . . . . .	2-19
Self-Tests . . . . .	2-19
IRIG-B Input Description . . . . .	2-22
Signal Processing . . . . .	2-22
Torque Control . . . . .	2-23
Demand Ammeters . . . . .	2-26
Fault Locator . . . . .	2-27
Event Report . . . . .	2-30
Time-Overcurrent Element Curve-Timing and Time Delay Reset Equations . . . . .	2-32

## COMMUNICATIONS

---

Introduction . . . . .	3-1
Serial Port Connections and Configurations . . . . .	3-1
Communications Protocol . . . . .	3-3
Command Characteristics . . . . .	3-5
Command Descriptions . . . . .	3-7
SEL-251D-1 Relay Command Summary . . . . .	3-35

## EVENT REPORTING

---

Event Report Generation . . . . .	4-1
Summary Event Report . . . . .	4-1
Long Event Report . . . . .	4-2
Interpreting Voltage and Current Data . . . . .	4-2
Relay Element, Output Contact, and Input Data . . . . .	4-4
Example Event Reports . . . . .	4-5
Firmware Identification . . . . .	4-10

## APPLICATIONS

---

Fuse-Saving Schemes . . . . .	5-1
Trip-Saving Scheme . . . . .	5-4
Blocking Schemes for Cold Load Inrush . . . . .	5-6
Disable Ground/Residual Overcurrent Elements . . . . .	5-9
Minimum Response Time for Time-Overcurrent Elements . . . . .	5-12
Underfrequency Load Shedding Input . . . . .	5-13
Undervoltage Load Shedding . . . . .	5-14
Breaker Failure . . . . .	5-15
Residual Current Unbalance Alarm . . . . .	5-17
Block Voltage Regulating Load-Tap-Changer Operation . . . . .	5-17
Extra Alarm Output Contact . . . . .	5-17
Backup Feeder Relays with a Bus Relay . . . . .	5-18
Feeder Relay Setting Changes . . . . .	5-19
Bus-Tie Relay Setting Changes . . . . .	5-20
Clock-Driven Setting Group Selection . . . . .	5-20
Demand-Driven Setting Group Selection . . . . .	5-20
System Restoration After Underfrequency Load Shedding . . . . .	5-21

## INSTALLATION

---

Installation . . . . .	6-1
Installation Checkout . . . . .	6-6
SEL Direction and Polarity Check Form . . . . .	6-13

## MAINTENANCE & TESTING

---

Test Procedures . . . . .	7-1
Initial Checkout . . . . .	7-4
Full Functional Test . . . . .	7-12
Setting Test . . . . .	7-13
Overcurrent Element Pickup Tests . . . . .	7-13
Definite-Time Overcurrent Element Timing Tests . . . . .	7-14
Time-Overcurrent Element Timing Tests . . . . .	7-15
Demand Ammeter Timing Tests . . . . .	7-17
Reclosing Relay Tests Setup . . . . .	7-18
Reclosing Relay Reset Interval Timer Test . . . . .	7-19
Reclosing Relay Open Interval Timer Test . . . . .	7-20
Reclosing Relay States Test . . . . .	7-21
Reclosing Relay Shot Bit Test . . . . .	7-22
Reclosing Relay Sequence Coordination Test . . . . .	7-24
Close Failure Timer Test . . . . .	7-26
Trip Failure Timer Test . . . . .	7-27
Input Circuits Test . . . . .	7-29
Serial Ports Test . . . . .	7-30
IRIG-B Time Code Input Test . . . . .	7-30
Power Supply Voltages Test . . . . .	7-30
Relay Calibration . . . . .	7-31
Troubleshooting . . . . .	7-31
Firmware Upgrade Instructions . . . . .	7-34
Factory Assistance . . . . .	7-36

## APPENDICES

---

Appendix A - Firmware Versions . . . . .	Appendix A-1
Appendix B - Internal Diagram . . . . .	Appendix B-1
Appendix C - Onebus: Program to Compute Test Set Settings for Testing Distance Relays . . . . .	Appendix C-1

## TABLES

Table 2.1:	Trip Circuit Monitor Alarm (TCMA) Truth Table . . . . .	2-6
Table 2.2:	SEL-251D-1 Relay Word . . . . .	2-10
Table 2.3:	Setting Group Selection Input Truth Table . . . . .	2-17
Table 2.4:	Power Supply Self-Test Limits . . . . .	2-20
Table 2.5:	Self-Test Summary . . . . .	2-21
Table 3.1:	SEL-251D-1 Relay Serial Port Connector Pin Assignments . . . . .	3-3
Table 3.2:	Target LED Assignments . . . . .	3-19
Table 4.1:	Event Report Triggering Actions . . . . .	4-1
Table 6.1:	IRIG-B Pin Definitions . . . . .	6-5
Table 7.1:	Fault Locator Test Values . . . . .	7-11
Table 7.2:	Current Quantities for 51NT Timing Test Example . . . . .	7-16
Table 7.3:	Contact Inputs and Terminal Numbers . . . . .	7-29

## FIGURES

Figure 2.1:	SEL-251D-1 Relay Inputs, Outputs, and Targets Diagram . . . . .	2-2
Figure 2.2:	Time Delayed 52A and 52B Functions . . . . .	2-5
Figure 2.3:	Trip Circuit Monitor (TCM) DC Voltage Connections . . . . .	2-5
Figure 2.4:	Trip Circuit Monitor Alarm (TCMA) Logic . . . . .	2-6
Figure 2.5:	SEL-251D-1 Relay SELOGIC Control Equations Block Diagram . . . . .	2-9
Figure 2.6:	Relay Word Bit Realizations . . . . .	2-11
Figure 2.7:	Relay Word Bit Realization . . . . .	2-12
Figure 2.8:	SEL-251D-1 Relay Front Panel Target LEDs . . . . .	2-13
Figure 2.9:	Sequence Coordination, Ground/Residual Overcurrent Elements . . . . .	2-15
Figure 2.10:	Distribution Transformer Bank Protected by High-Side Fuses . . . . .	2-25
Figure 2.11:	Source and Line Impedances . . . . .	2-27
Figure 2.12:	Nomograph for Fault Locating . . . . .	2-30
Figure 2.13:	Moderately Inverse Curves . . . . .	2-33
Figure 2.14:	Inverse Curves . . . . .	2-33
Figure 2.15:	Very Inverse Curves . . . . .	2-33
Figure 2.16:	Extremely Inverse Curves . . . . .	2-33
Figure 2.17:	Short-Time Inverse Curves . . . . .	2-34
Figure 2.18:	SEL-251D-1 Phase Overcurrent Logic Diagrams . . . . .	2-35
Figure 2.19:	SEL-251D-1 Ground/Residual Overcurrent Logic Diagrams . . . . .	2-36
Figure 2.20:	SEL-251D-1 Ground/Residual Overcurrent Logic Diagrams . . . . .	2-37
Figure 2.21:	SEL-251D-1 Overcurrent and Undervoltage Elements . . . . .	2-38
Figure 2.22:	SEL-251D-1 Transformer Blown-Fuse Detection Logic . . . . .	2-39
Figure 2.23:	SEL-251D-1 Demand Ammeters . . . . .	2-40
Figure 2.24:	SEL-251D-1 Programmable Trip Logic Diagram . . . . .	2-41
Figure 2.25:	SEL-251D-1 Close Logic Diagram . . . . .	2-42
Figure 3.1:	9-Pin Connector Pin Number Convention . . . . .	3-2



Figure 5.1:	Fuse Saving Using Ground/Residual Elements . . . . .	5-1
Figure 5.2:	Reclosing Cycle for Permanent Fault Beyond Tap Fuse . . . . .	5-2
Figure 5.3:	Effect of 52APU and 52ADO Settings on Relay Word Bits 52AT and 52BT . . . . .	5-3
Figure 5.4:	Trip Saving Using Ground/Residual Elements . . . . .	5-5
Figure 5.5:	50C Delayed by TSPU Time . . . . .	5-7
Figure 5.6:	Effect of 52APU and 52ADO Settings on Relay Word Bits 52AT and 52BT . . . . .	5-8
Figure 5.7:	Minimum Response Time Using Ground/Residual Elements . . . . .	5-13
Figure 5.8:	Input IN5 Qualified by Time TKPU . . . . .	5-14
Figure 5.9:	Element 27 Qualified by Time TKPU . . . . .	5-14
Figure 5.10:	Underfrequency or Undervoltage Trip Condition Time Duration Limit . . . . .	5-16
Figure 5.11:	Distribution Feeder Relay Backup Scheme . . . . .	5-19
Figure 5.12:	Main/Auxiliary Bus with Bus-Tie Circuit Breaker . . . . .	5-20
Figure 5.13:	Underfrequency Load Shedding and Reclose Initiate Supervision . . . . .	5-22
Figure 5.14:	Timing for Reclose Initiation . . . . .	5-23
Figure 6.1:	9-Pin Connector Pin Number Convention . . . . .	6-4
Figure 6.2:	SEL-251D-1 Relay Horizontal Front and Rear Panel Drawings . . . . .	6-8
Figure 6.3:	Relay Dimensions, Panel Cutout, and Drill Diagrams . . . . .	6-9
Figure 6.4:	Communications and Clock Connections - One Unit at One Location . . . . .	6-10
Figure 6.5:	Remote Communications, Local Display, and Clock Connections - Multiple Relay Units at One Location . . . . .	6-10
Figure 6.6:	SEL Relay Communications Diagram for Connection to the SEL-DTA . . . . .	6-11
Figure 6.7:	SEL-251D-1 Relay Typical AC External Current and Voltage Connections . . . . .	6-11
Figure 6.8:	SEL-251D-1 Relay Typical DC External Connections . . . . .	6-12
	SEL Direction and Polarity Check Form . . . . .	6-13
Figure 7.1:	Low-Level Test Interface . . . . .	7-2
Figure 7.2:	Relay Part Number and Hardware Identification Sticker . . . . .	7-5
Figure 7.3:	Communication Interface Setup . . . . .	7-6
Figure 7.4:	Three-Phase Voltage and Current Source Test Connections . . . . .	7-10
Figure 7.5:	9-Pin Connector Pin Number Convention . . . . .	



**INTRODUCTION  
TABLE OF CONTENTS**

---

Getting Started . . . . .	1-1
Overview . . . . .	1-1
General Description . . . . .	1-2



# INTRODUCTION

---

## GETTING STARTED

If you are not familiar with this relay, we suggest that you read this introduction, then perform the Initial Checkout Procedure in Section 7: MAINTENANCE & TESTING.

## OVERVIEW

The SEL-251D-1 Relay is designed to protect distribution lines for all fault types. It is intended for use on grounded systems with delta-connected voltage transformers. The following list outlines protective features, performance, and versatility gained when applying the SEL-251D-1 Relay to your installations.

- Develop traditional and advanced schemes using flexible SELOGIC™ Control Equations
- Phase-overcurrent elements have voltage control for load security
- Ground/Residual overcurrent elements cover ground faults
- Choose fast or electromechanical reset characteristic for time-overcurrent elements
- Overcurrent elements inhibit recloser reset to prevent nuisance "trip-reclose" cycling
- Sequence coordination avoids unnecessary tripping for faults beyond line reclosers
- Undervoltage logic detects high-side transformer fuse operations
- Six selectable setting groups cover all feeder protection contingencies
- Circuit breaker monitor sums interrupted current in each pole to aid maintenance
- Fault locator reduces line patrol and outage time for increased service reliability
- Eleven-cycle event report simplifies fault and system analysis
- Comprehensive voltage, current, power, unbalance, and demand metering
- Connects to SEL-RD RELAY DISPLAY for easy information access

The SEL-251D-1 Relay improves every aspect of feeder protection.

- Security: Undervoltage supervision avoid load encroachment
- Reliability: Field-proven hardware; new backup concepts
- Flexibility: SELOGIC Control Equations handle virtually every conceivable scheme
- Capability: Brings transmission relay features to distribution applications
- Economy: Low price and unique features make the relay an exceptional value

## **GENERAL DESCRIPTION**

The SEL-251D-1 Relay protects, controls, and monitors distribution feeders. It offers important new and unique features, like user-programmable SELOGIC Control Equations, and selectable setting groups. The advanced relay design enhances security, reliability, sensitivity, and operation.

### **SELOGIC Control Equations: The Next Step in Programmable Relay Logic**

In 1987, SEL<sup>®</sup> invented Programmable Mask Logic. The SEL-251D-1 Relay offers SELOGIC Control Equations, the next step in user-programmability. SELOGIC Control Equations include ANDing, ORing, and inverting functions, timing, and programmable inputs and outputs. SELOGIC Control Equations add power and flexibility while simplifying programming.

### **Phase and Ground Overcurrent Protection**

Phase overcurrent elements detect phase faults. On heavily-loaded feeders, undervoltage torque control of phase overcurrent elements adds security. Ground/Residual overcurrent elements detect ground faults, and external inputs can torque control selected overcurrent elements.

There are two reset characteristic choices for the time-overcurrent elements. One choice resets the elements if current drops below pickup for at least one cycle. The other choice emulates electromechanical induction disc elements where the reset time depends on the time dial setting, the percentage of disc travel, and the amount of current between zero and pickup.

### **Sophisticated Multiple-Shot Reclosing Relay Includes Reset Inhibit and Sequence Coordination**

The reclosing relay allows up to four reclosing shots with separate, settable open interval timers and reset interval timer. Overcurrent conditions during the reclosing relay reset interval inhibit the reset interval timer. This prevents the reclosing relay from resetting when a trip condition is imminent. A close failure timer can limit CLOSE output contact assertion. Reclose cancel conditions are programmable. A programmable input can be used as a reclose enable input to disable/enable the reclosing relay.

The SEL-251D-1 Relay includes easily programmable sequence coordination to keep the relay in step with line reclosers, preventing undesired tripping for faults beyond line reclosers.

### **Six Selectable Groups of Settings and Logic**

The relay stores six setting groups. Select the active setting group by contact input or command. Use these setting groups to cover a wide range of distribution feeder protection contingencies. Selectable setting groups make the SEL-251D-1 Relay ideal for bus-tie and substitute breaker applications and other applications requiring frequent setting changes.

### **Circuit Breaker Monitor Tracks Breaker Performance and Helps Maintenance Planning**

Separate circuit breaker trip counters differentiate and tally relay-initiated trips and external trips. Running sums of interrupted current for relay and external trips indicate breaker wear and tear on a pole-by-pole basis. Use these data to schedule breaker maintenance.

Trip failure logic provides alarm and breaker failure functions. A close failure alarm indicates circuit breaker closing circuit or mechanism problems. The trip circuit monitor detects abnormal open or short circuits in the circuit breaker tripping circuit or status input.

### **Fault Locator Reduces Line Patrol and Outage Time**

The SEL-251D-1 Relay includes a fault locator which uses fault type, pre-fault, and fault conditions to provide an accurate estimate of fault location without communications channels, special instrument transformers, even during conditions of substantial load flow and fault resistance. Fault locating reduces line patrol and outage time.

### **Analyze Operations Using Event Reports**

Eleven-cycle event reports triggered by user selected conditions provide the current, voltage, and sequence-of-events information you need to understand relay and circuit breaker performance, as well as stress on the feeder for every fault.

### **Comprehensive Metering Supports Protection, Operation, and Demand Analysis**

The relay measures phase and zero-sequence currents, phase-to-phase voltages, as well as MW and MVAR. Demand and peak demand values for current, MW, and MVAR are also available. Metering also supports protection, because you can inspect the quantities monitored by relay elements. Check for load encroachment and unbalance through instantaneous, demand, and peak-demand measurements.

### **Access SEL-251D-1 Relay Information Via the SEL-RD Relay Display**

You can connect up to four SEL-251D-1 Relays to one SEL-RD Relay Display. Access relay target, meter, status, fault history, and circuit breaker information via the relay display. You can even change the active setting group via the display.





# SPECIFICATIONS

## TABLE OF CONTENTS

---

General Specifications . . . . .	2-1
Functional Specifications . . . . .	2-3
SEL-251D-1 Relay SELOGIC Control Equations . . . . .	2-7
Targets . . . . .	2-13
Multiple Shot Reclosing Relay . . . . .	2-14
Selectable Setting Groups . . . . .	2-17
Circuit Breaker Monitor . . . . .	2-18
Metering . . . . .	2-18
Serial Interfaces . . . . .	2-19
Self-Tests . . . . .	2-19
IRIG-B Input Description . . . . .	2-22
Signal Processing . . . . .	2-22
Torque Control . . . . .	2-23
Demand Ammeters . . . . .	2-26
Fault Locator . . . . .	2-27
Event Report . . . . .	2-30
Time-Overcurrent Element Curve-Timing and Time Delay Reset Equations . . . . .	2-32

## TABLES

Table 2.1: Trip Circuit Monitor Alarm (TCMA) Truth Table . . . . .	2-6
Table 2.2: SEL-251D-1 Relay Word . . . . .	2-10
Table 2.3: Setting Group Selection Input Truth Table . . . . .	2-17
Table 2.4: Power Supply Self-Test Limits . . . . .	2-20
Table 2.5: Self-Test Summary . . . . .	2-21

## FIGURES

Figure 2.1:	SEL-251D-1 Relay Inputs, Outputs, and Targets Diagram . . . . .	2-2
Figure 2.2:	Time Delayed 52A and 52B Functions . . . . .	2-5
Figure 2.3:	Trip Circuit Monitor (TCM) DC Voltage Connections . . . . .	2-5
Figure 2.4:	Trip Circuit Monitor Alarm (TCMA) Logic . . . . .	2-6
Figure 2.5:	SEL-251D-1 Relay SELOGIC Control Equations Block Diagram . . . . .	2-9
Figure 2.6:	Relay Word Bit Realizations . . . . .	2-11
Figure 2.7:	Relay Word Bit Realization . . . . .	2-12
Figure 2.8:	SEL-251D-1 Relay Front Panel Target LEDs . . . . .	2-13
Figure 2.9:	Sequence Coordination, Ground/Residual Overcurrent Elements . . . . .	2-15
Figure 2.10:	Distribution Transformer Bank Protected by High-Side Fuses . . . . .	2-25
Figure 2.11:	Source and Line Impedances . . . . .	2-27
Figure 2.12:	Nomograph for Fault Locating . . . . .	2-30
Figure 2.13:	Moderately Inverse Curves . . . . .	2-33
Figure 2.14:	Inverse Curves . . . . .	2-33
Figure 2.15:	Very Inverse Curves . . . . .	2-33
Figure 2.16:	Extremely Inverse Curves . . . . .	2-33
Figure 2.17:	Short-Time Inverse Curves . . . . .	2-34
Figure 2.18:	SEL-251D-1 Phase Overcurrent Logic Diagrams . . . . .	2-35
Figure 2.19:	SEL-251D-1 Ground/Residual Overcurrent Logic Diagrams . . . . .	2-36
Figure 2.20:	SEL-251D-1 Ground/Residual Overcurrent Logic Diagrams . . . . .	2-37
Figure 2.21:	SEL-251D-1 Overcurrent and Undervoltage Elements . . . . .	2-38
Figure 2.22:	SEL-251D-1 Transformer Blown-Fuse Detection Logic . . . . .	2-39
Figure 2.23:	SEL-251D-1 Demand Ammeters . . . . .	2-40
Figure 2.24:	SEL-251D-1 Programmable Trip Logic Diagram . . . . .	2-41
Figure 2.25:	SEL-251D-1 Close Logic Diagram . . . . .	2-42

# SPECIFICATIONS

---

## GENERAL SPECIFICATIONS

<b><u>Voltage Inputs</u></b>	120 volt nominal phase-to-phase, three-phase, 3-wire connection 150 volt phase-to-phase saturation limit	
<b><u>Current Inputs</u></b>	5 A nominal 15 A continuous	110 A saturation limit 500 A one second thermal rating
<b><u>Output Contact Current Ratings</u></b>	30 A make per IEEE C37.90 6 A carry continuously; MOV protection provided	
<b><u>Optical Isolator Logic Input Ratings</u></b>	24 Vdc: 15 - 30 Vdc 48 Vdc: 30 - 60 Vdc Current = 4 mA at nominal voltage	125 Vdc: 80 - 150 Vdc 250 Vdc: 150 - 300 Vdc
<b><u>Power Supply</u></b>	24/48 Volt: 20 - 60 Vdc; 125/250 Volt: 85 - 350 Vdc or 85 - 264 Vac 10 watts nominal, 14 watts max. (all output relays energized)	
<b><u>Communications</u></b>	Two EIA RS-232-C serial communications ports, Port 2 of the SEL-251D-1 Relay has front and rear panel connectors.	
<b><u>Dimensions</u></b>	3.47" x 19.00" x 9.00" (8.81 cm x 48.26 cm x 22.86 cm) (H x W x D) Depth (D) is to end of the rear panel terminal blocks	
<b><u>Time Code Input</u></b>	Relay accepts demodulated IRIG-B time code input	
<b><u>Mounting</u></b>	Available in horizontal and vertical mounting configurations	
<b><u>Dielectric Strength</u></b>	V, I inputs: 2500 Vac for 10 seconds Other: 3000 Vdc for 10 seconds (excludes EIA RS-232-C)	
<b><u>Operating Temperature</u></b>	-40° F to 158° F (-40° C to 70° C)	
<b><u>Environment</u></b>	IEC 68-2-30 Temperature/Humidity Cycle Test - six day (type tested)	
<b><u>Interference Tests</u></b>	IEEE C37.90 SWC Test (type tested); IEC 255-6 Interference Test (type tested) IEC 801-4 Electrical Fast Transient/Burst (type tested)	
<b><u>Impulse Tests</u></b>	IEC 255-5 0.5 Joule, 5000 Volt Test (type tested)	
<b><u>RFI Tests</u></b>	Type tested in field from a quarter-wave antenna driven by 20 watts at 150 MHz and 450 MHz, randomly keyed on and off one meter from relay.	

**Vibration and Shock Test**

IEC 255-21-1 & -2, Class 1 Test (type tested)

**ESD Test**

IEC 801-2 Electrostatic Discharge Test (type tested)

**Unit Weight**

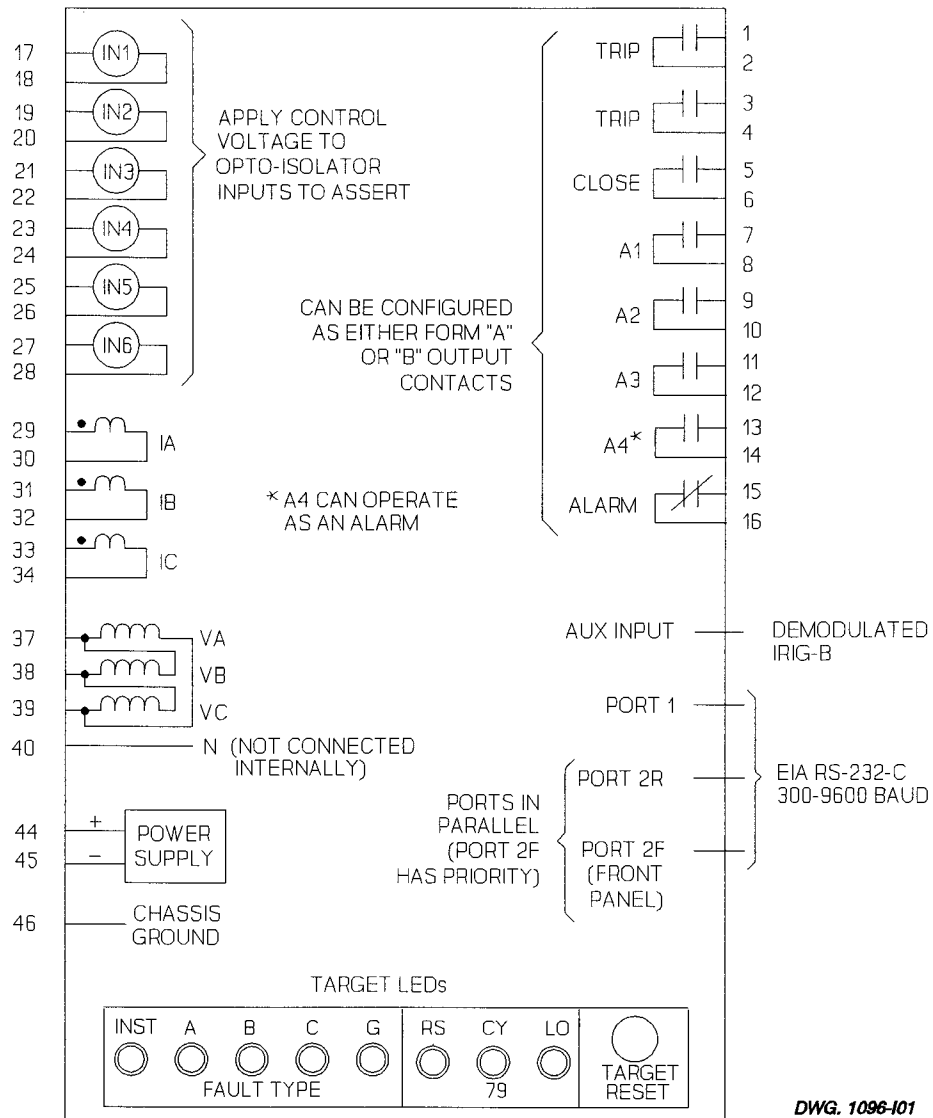
12 pounds (5.5 kg), SEL-251D-1 Relay

**Shipping Weight**

20 pounds (9.1 kg), SEL-251D-1 Relay, including one instruction manual.

**Burn-in Temperature**

Each relay is burned in at 140°F (60°C) for 100 hours.



**Figure 2.1: SEL-251D-1 Relay Inputs, Outputs, and Targets Diagram**

# FUNCTIONAL SPECIFICATIONS

## Phase Overcurrent Elements for Phase and Three-Phase Faults - See Figures 2.18 and 2.21

- 51T** Phase Time-Overcurrent Element
- Curve families: moderately inverse, inverse, very inverse, extremely inverse, short-time inverse
  - Time dial: 0.5 to 15.00 in 0.01 steps.
  - Pickup (**51P**): 1 to 12 A  $\pm 2\%$  of setting  $\pm 0.1$  A secondary
  - Time delay or 1-cycle reset time
  - Timing:  $\pm 5\%$  and  $\pm 1$  cycle for currents between 2 and 20 multiples of pickup
  - Internally and externally torque controllable
- 50LT** Phase Definite-Time Overcurrent Element
- Pickup (**50L**): 0.5 to 100 A  $\pm 2\%$  of setting  $\pm 0.1$  A secondary
  - Time delay: 0 to 16,000 cycles in 1-cycle steps
  - Internally and externally torque controllable
- 50H** Phase Instantaneous Overcurrent Element
- Pickup: 0.5 to 100 A  $\pm 2\%$  of setting  $\pm 0.1$  A secondary
  - Internally and externally torque controllable
- 50C** Phase Instantaneous Overcurrent Element
- Pickup: 0.5 to 100 A  $\pm 2\%$  of setting  $\pm 0.1$  A secondary
  - Operates on "2 out of 3" logic:  $50C = 50C_A * 50C_B + 50C_B * 50C_C + 50C_C * 50C_A$
  - Can internally torque control other phase overcurrent elements (TCI setting)

## Ground/Residual Overcurrent Elements for Ground Faults - See Figure 2.19

- 51GT** Ground/Residual Time-Overcurrent Element
- Curve families: moderately inverse, inverse, very inverse, extremely inverse, short-time inverse
  - Time dial: 0.5 to 15.00 in 0.01 steps.
  - Pickup (**51GP**): 1 to 12 A  $\pm 3\%$  of setting  $\pm 0.18$  A secondary
  - Time delay or 1-cycle reset time
  - Timing:  $\pm 5\%$  and  $\pm 1$  cycle for currents between 2 and 20 multiples of pickup
  - Externally torque controllable
- 50GT** Ground/Residual Definite-Time Overcurrent Element
- Pickup (**50G**): 0.5 to 100 A  $\pm 3\%$  of setting  $\pm 0.18$  A secondary
  - Time delay: 0 to 16,000 cycles in 1-cycle steps
  - Externally torque controllable

## Ground/Residual Overcurrent Elements for Ground Faults - See Figure 2.20

### **51NT** Ground/Residual Time-Overcurrent Element

- Curve families: moderately inverse, inverse, very inverse, extremely inverse, short-time inverse
- Time dial: 0.5 to 15.00 in 0.01 steps
- Pickup (**51NP**): 0.25 to 12 A secondary
- Time delay or 1-cycle reset time
- Timing:  $\pm 5\%$  and  $\pm 1$  cycle for currents between 2 and 20 multiples of pickup
- Externally torque controllable

### **50NLT** Ground/Residual Definite-Time Overcurrent Element

- Pickup (**50NL**): 0.5 to 100 A secondary (for  $1 \leq 51NP \leq 12$  A secondary)  
0.25 to 50 A secondary (for  $0.5 \leq 51NP < 1$  A secondary)  
0.125 to 25 A secondary (for  $0.25 \leq 51NP < 0.5$  A secondary)
- Time delay: 0 to 16,000 cycles in 1-cycle steps
- Externally torque controllable

### **50NH** Ground/Residual Instantaneous Overcurrent Element

- Pickup: same range as **50NLT**
- Externally torque controllable

### **Accuracy**

- Residual element pickup accuracy is dependent upon the 51NP setting. Pickup accuracy of the 51NP, 50NL, and 50NH elements is shown below in the given 51NP setting range.

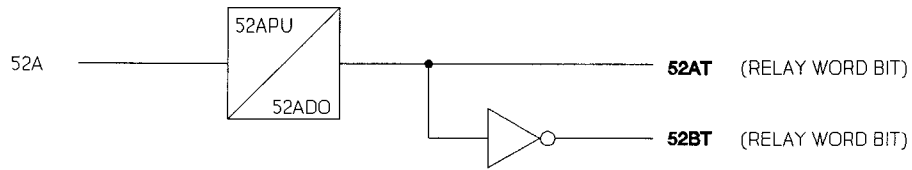
1.0	$\leq 51NP \leq 12.0$ A sec	Pickup $\pm 2\% \pm 0.100$ A sec
0.5	$\leq 51NP < 1.0$ A sec	Pickup $\pm 2\% \pm 0.050$ A sec
0.25	$\leq 51NP < 0.5$ A sec	Pickup $\pm 2\% \pm 0.025$ A sec

## Voltage Element for Healthy/Low Voltage Indication or Internal Control (27) - See Figure 2.21

- 27AB, 27BC, 27CA Phase-to-Phase Voltage Elements
- Setting Range: 0 to 140 V line-to-line secondary  $\pm 5\%$ ,  $\pm 1$  V
- Two setting limits: 27H and 27L (high and low, respectively)
- 27 element asserts only if voltage is between 27H and 27L
- User selects either three-phase or phase-to-phase voltage condition
- Implement undervoltage load-shedding scheme
- Internally torque control selected phase overcurrent elements
- Detect high-side transformer fuse operations

## Time Delayed 52A or 52B Functions Handle Fuse-Saving and Inrush

The time delay pickup and time delay dropout settings (52APU and 52ADO, respectively) are provided to generate the 52AT and 52BT functions. The 52AT and 52BT bits can be used to supervise overcurrent elements for fuse saving and inrush conditions.



**Figure 2.2: Time Delayed 52A and 52B Functions**

**Trip Failure Timer Detects Breaker Failure or Slow Trip - See Figure 2.24**

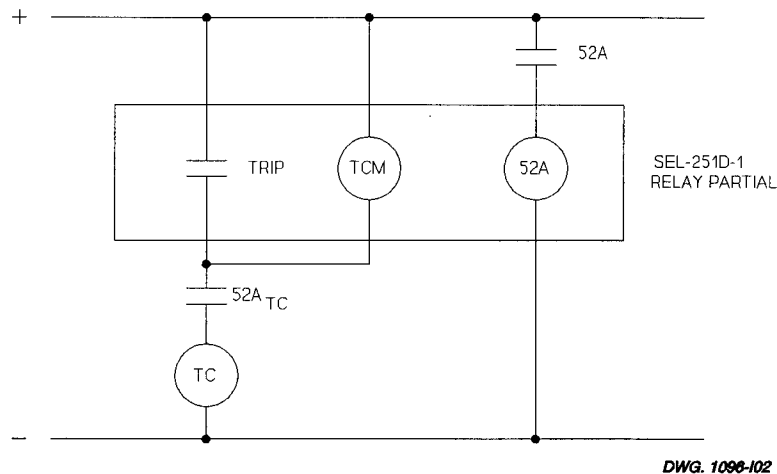
A relay trip starts a trip failure timer. If the trip condition lasts longer than the TFT setting, the **TF** bit in the Relay Word asserts. The **TF** bit deasserts 60 cycles after the trip condition drops out. The **TF** bit can be assigned to an output contact to alarm for slow trips or to provide breaker failure tripping. It can also be used to cancel reclosing or trigger an event report.

**Close Failure Timer Detects Failure to Close or Slow Close - See Figure 2.25**

A close failure timer monitors the length of time the **CLOSE** output contact remains asserted. If **CLOSE** output contact assertion exceeds the **CFT** time setting, the close attempt is unsuccessful. The relay opens the **CLOSE** output contact, the reclosing relay locks out, and the **CF** bit in the Relay Word asserts. The **CF** bit asserts for 60 cycles. Use the **CF** bit to alarm for close failures or slow-close conditions and to trigger event reports.

**Trip Circuit Monitor Alarm Checks Trip Circuit and Verifies Circuit Breaker Status Input**

You can assign one of the six programmable inputs to the trip circuit monitor (TCM) logic.



**Figure 2.3: Trip Circuit Monitor (TCM) DC Voltage Connections**

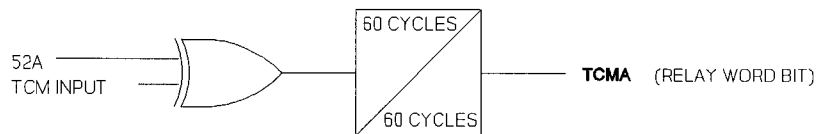
When the circuit breaker is closed (consequently 52A<sub>TC</sub> is closed) and the TRIP output contact is not asserted, the TCM input allows a few milliamperes of current through the trip coil. The voltage drop is across the TCM input because the input has a much higher impedance than the trip coil.

Trip circuit monitor logic ensures that the 52A and TCM inputs agree. When the circuit breaker is closed, inputs 52A and TCM are energized; 52A and 52A<sub>TC</sub> contacts are closed. When the circuit breaker is open, inputs 52A and TCM are de-energized; 52A and 52A<sub>TC</sub> contacts are open. If the two inputs disagree for 60 cycles, the trip circuit monitor alarm (TCMA) bit asserts in the Relay Word. The TCMA bit deasserts 60 cycles after the TCMA condition ends.

**Table 2.1: Trip Circuit Monitor Alarm (TCMA) Truth Table**

<u>TCM input</u>	<u>52A</u>	<u>TCMA Relay Word bit</u>	<u>Notes</u>
0	0	0	
0	1	1	(a)
1	0	1	(b)
1	1	0	

- (a) Abnormal open circuit in TCM input/lower trip circuit path  
or a short circuit exists across the TCM input (e.g., TRIP output is asserted)  
or 52A contact short circuited or "stuck closed"
- (b) 52A<sub>TC</sub> short circuited or "stuck closed"  
or there is an abnormal open circuit in the 52A input circuit path



**Figure 2.4: Trip Circuit Monitor Alarm (TCMA) Logic**

Besides alarming for an abnormal open circuit in the trip circuit, the TCMA bit provides 52A input verification. It effectively compares the circuit breaker status input to 52A<sub>TC</sub>.

The TCMA bit can be used to alarm, cancel reclosing, or trigger event reports.

In Figure 2.3, a 52A contact is connected to relay input 52A. You can connect a 52B contact instead. Wire a 52B contact to a relay input !52A to perform the 52A function. Input options 52AR or !52AR can also be used. (See SEL-251D-1 Relay SELoGIC™ Control Equations.)



## SEL-251D-1 RELAY SELOGIC CONTROL EQUATIONS

SELOGIC Control Equations put relay logic in the hands of the relay applications engineer. Assign the inputs to suit your application, logically combine selected relay elements for various control functions, use non-dedicated timers for special applications, and assign output relays to your logic functions.

Programming SELOGIC Control Equations consists of assigning functions to the programmable inputs, designing the internal logic you need, expressing that logic in terms of the relay elements and internal logic variables, and defining the output functions. The SET command controls all SELOGIC Control Equations programming (See Section 3: COMMUNICATIONS). Section 5: APPLICATIONS gives several examples of implementing protection schemes with SELOGIC Control Equations. Sample SELOGIC Control Equations are given in Example Event Report 2 in Section 4: EVENT REPORTING.

Figure 2.5 shows how Relay Word rows R5 and R6 in Table 2.2 and the output functions are derived.

### Assign Inputs to the Functions You Need

Program the six isolated inputs (IN1 through IN6) to the functions your application requires. Choose from the following functions:

		<u>Default Logic States</u>
SS1	Setting Group Selection Input 1 (assign to IN1 only)	0
SS2	Setting Group Selection Input 2 (assign to IN2 only)	0
SS3	Setting Group Selection Input 3 (assign to IN3 only)	0
TCP	External Torque Control (Phase Elements)	1
!TCP	(inverted sense of TCP)	0
TCG	External Torque Control (Residual Overcurrent Elements)	1
!TCG	(inverted sense of TCG)	0
52A	Circuit Breaker Status (52A contact input)*	N/A
!52A	Circuit Breaker Status (52B contact input)*	N/A
52AR	Circuit Breaker Status (52A contact input)/Reclose Initiate*	N/A
!52AR	Circuit Breaker Status (52B contact input)/Reclose Initiate*	N/A
DC	Direct Close (requires circuit breaker status)	0
RE	Reclose Enable (requires circuit breaker status)	1
!RE	(inverted sense of RE) (requires circuit breaker status)	0
TCM	Trip Circuit Monitor (requires circuit breaker status)	N/A
ET	External Trigger of Event Report	0
DT	Direct Trip	0
(blank)	Unassigned input	

- \* Only one of the circuit breaker status input options 52A, !52A, 52AR, or !52AR should be assigned to an input.

### **52A or !52A**

If 52A or !52A is assigned to an input, only circuit breaker status information is provided. Reclose initiation is provided by the assertion of the internal TRIP condition. When the TRIP condition drops out and the circuit breaker is open (per 52A or !52A), the open interval starts timing.

### **52AR or !52AR**

If 52AR or !52AR is assigned to an input, not only does the input provide circuit breaker status information, but it provides reclose initiation, too. The sensed transition of the circuit breaker status, indicating that the circuit breaker is opening, initiates reclosing. If the TRIP condition is present, it has to drop out before the open interval starts timing.

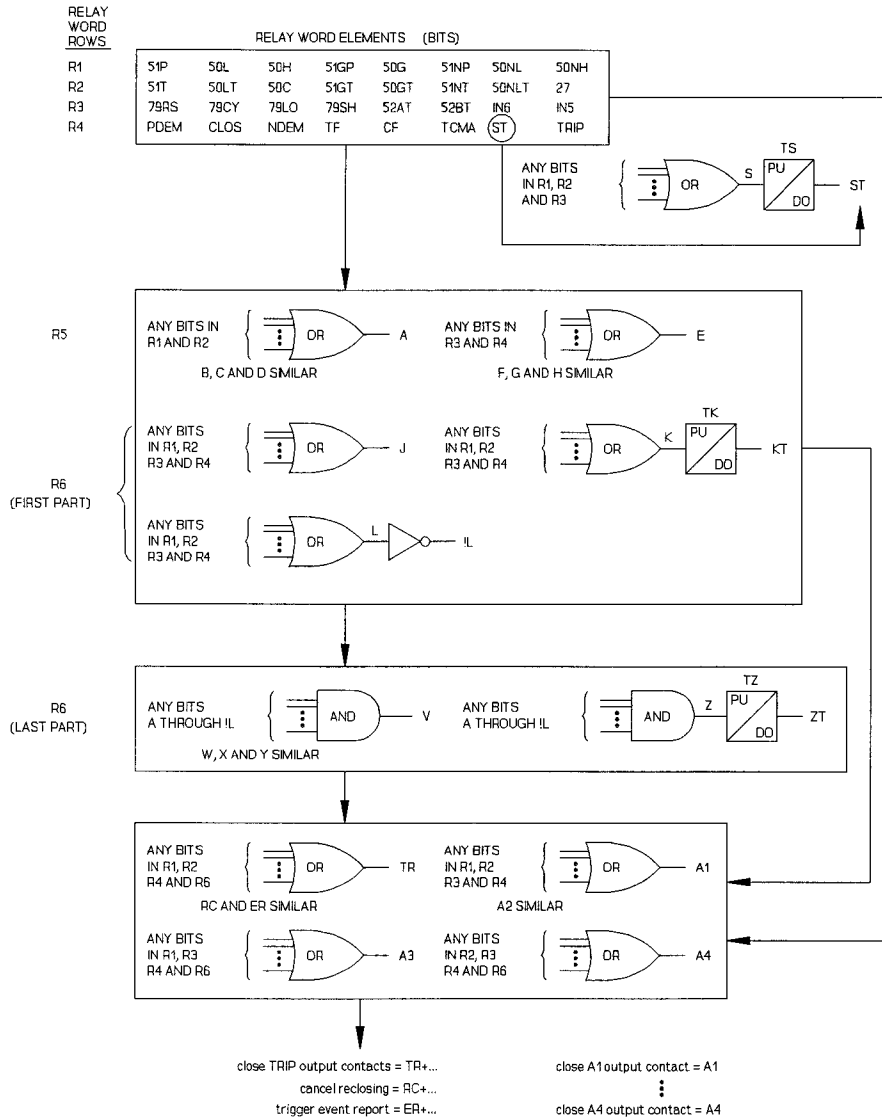
In most applications, circuit breaker trips external to the relay (e.g., by control switch or SCADA) must not cause reclose initiation. If input option RE (Reclose Enable) is assigned to an input, the RE input is de-energized to prevent automatic reclosing. Certain control switch contacts can be wired to the RE input to defeat reclosing for control switch trips.

Also, if 52AR or !52AR is assigned to an input, the circuit breaker status function is time delayed by 10 cycles to qualify circuit breaker opening. This is done for certain application needs (see SYSTEM RESTORATION AFTER UNDER-FREQUENCY LOAD SHEDDING in Section 5: APPLICATIONS). If this type of application is not needed, then it is better to assign 52A or !52A to an input instead and avoid the 10-cycle time delay. This time delay shows up in event reports and needs to be accounted for when making setting 52ADO.

The 10-cycle delay affects the circuit breaker monitor, too. The TDUR timer should be set somewhat greater than 10 cycles so that relay initiated circuit breaker trips are counted as such and not as external circuit breaker trips. Also, if an external trip occurs, no interrupted current values will likely be accumulated by the circuit breaker monitor because of the 10-cycle time delay.

Inputs IN5 and IN6 also appear directly in the Relay Word for use in the programmable logic. Inputs IN1, IN2, and IN3 can be assigned to functions other than just SS1, SS2, and SS3, respectively.

Assert an input by applying control voltage to the corresponding rear panel input terminals. Control voltage polarity is not important. When a function is not assigned to an input, the relay uses the respective default logic state shown above.



**Figure 2.5: SEL-251D-1 Relay SELOGIC Control Equations Block Diagram**

**Select Combinations of Relay Elements for Tripping and Other Purposes**

The 48-bit Relay Word contains relay elements, intermediate logic results, and programmable logic variables.

**Table 2.2: SEL-251D-1 Relay Word**

R1	<b>51P</b>	<b>50L</b>	<b>50H</b>	<b>51GP</b>	<b>50G</b>	<b>51NP</b>	<b>50NL</b>	<b>50NH</b>
R2	<b>51T</b>	<b>50LT</b>	<b>50C</b>	<b>51GT</b>	<b>50GT</b>	<b>51NT</b>	<b>50NLT</b>	<b>27</b>
R3	<b>79RS</b>	<b>79CY</b>	<b>79LO</b>	<b>79SH</b>	<b>52AT</b>	<b>52BT</b>	<b>IN6</b>	<b>IN5</b>
R4	<b>PDEM</b>	<b>CLOS</b>	<b>NDEM</b>	<b>TF</b>	<b>CF</b>	<b>TCMA</b>	<b>ST</b>	<b>TRIP</b>
R5	<b>A</b>	<b>B</b>	<b>C</b>	<b>D</b>	<b>E</b>	<b>F</b>	<b>G</b>	<b>H</b>
R6	<b>J</b>	<b>KT</b>	<b>!L</b>	<b>V</b>	<b>W</b>	<b>X</b>	<b>Y</b>	<b>ZT</b>

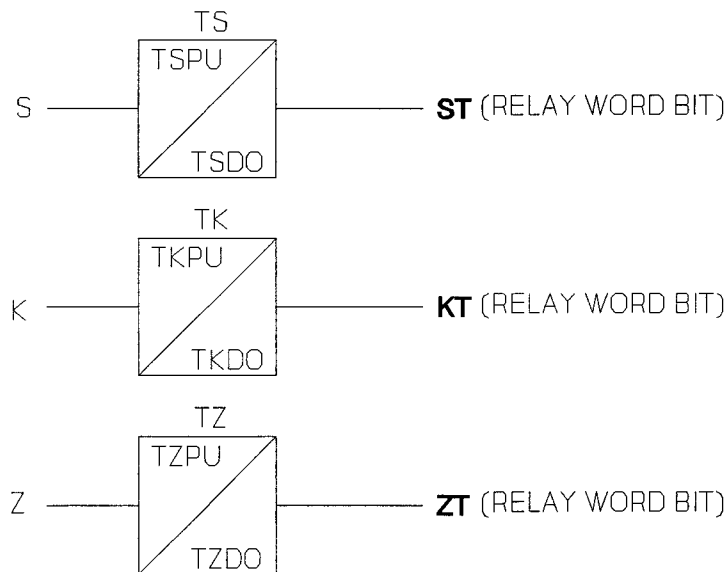
! indicates NOT

<b>51P</b>	Phase time-overcurrent element pickup
<b>50L</b>	Phase definite-time overcurrent element pickup
<b>50H</b>	Phase instantaneous overcurrent element
<b>51GP</b>	Ground/Residual time-overcurrent element pickup
<b>50G</b>	Ground/Residual definite-time overcurrent element pickup
<b>51NP</b>	Ground/Residual time-overcurrent element pickup
<b>50NL</b>	Ground/Residual definite-time overcurrent element pickup
<b>50NH</b>	Ground/Residual instantaneous overcurrent element
<b>51T</b>	Phase time-overcurrent element
<b>50LT</b>	Phase definite-time overcurrent element
<b>50C</b>	Phase instantaneous overcurrent element (operates on "2 out of 3" logic)
<b>51GT</b>	Ground/Residual time-overcurrent element
<b>50GT</b>	Ground/Residual definite-time overcurrent element
<b>51NT</b>	Ground/Residual time-overcurrent element
<b>50NLT</b>	Ground/Residual definite-time overcurrent element
<b>27</b>	Phase undervoltage element for internal torque control and blown-fuse detection
<b>79RS</b>	Reclosing relay is in the reset state
<b>79CY</b>	Reclosing relay is in the reclose cycle state
<b>79LO</b>	Reclosing relay is in the lockout state
<b>79SH</b>	Shot bit; asserts for shots selected by the M79SH setting
<b>52AT</b>	Time delayed 52A
<b>52BT</b>	Inverse of <b>52AT</b>
<b>IN6</b>	Input IN6 bit; asserts for control voltage applied to input IN6
<b>IN5</b>	Input IN5 bit; asserts for control voltage applied to input IN5
<b>PDEM</b>	Phase demand current threshold exceeded
<b>CLOS</b>	Follows state of CLOSE output contact
<b>NDEM</b>	Ground/Residual demand current threshold exceeded
<b>TF</b>	Trip failure condition
<b>CF</b>	Close failure condition
<b>TCMA</b>	Trip circuit monitor alarm: asserts for abnormal open or short circuit in the circuit breaker tripping circuit or circuit breaker status input

<b>ST</b>	Output from timer TS, driven by any OR-combination of elements in R1 through R3 assigned to setting S
<b>TRIP</b>	Follows state of the TRIP output contacts
<b>A B C D</b>	Select any OR-combination of elements in R1 and R2
<b>E F G H</b>	Select any OR-combination of elements in R3 and R4
<b>J</b>	Select any OR-combination of elements in R1 through R4
<b>KT</b>	Output from timer TK, driven by any selected OR-combination of elements in R1 through R4 assigned to setting K
<b>!L</b>	Output from an inverter, driven by any selected OR-combination of elements in R1 through R4 assigned to setting L
<b>V W X Y</b>	Select any AND-combination of elements A through !L
<b>ZT</b>	Output from timer TZ, driven by any selected AND-combination of elements A through !L assigned to setting Z

### Time Delayed Variables ST, KT, and ZT

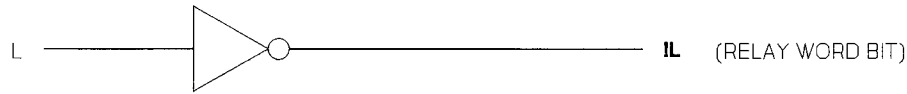
Relay Word variables **ST**, **KT**, and **ZT** are outputs from time delay pickup/dropout timers TS, TK and TZ, respectively. TS and TK are driven by any OR-combination of Relay Word elements in R1...R3 and R1...R4, respectively. Any AND-combination of Relay Word elements A through !L may drive timer TZ.



**Figure 2.6: Relay Word Bit Realizations**

## Use !L for Inversion

Variable L is any OR-combination of elements in R1 through R4. The inverse of L (!L) is in the Relay Word. Also, output contacts A1 ... A4 and the ALARM can be configured as either "a" or "b" contacts for an additional inversion.



**Figure 2.7: Relay Word Bit Realization**

## Programming Output Contacts

Write output equations to define tripping and other control functions.

- TRIP: Select any OR-combination of elements in R1, R2, R4, and R6 via the TR(1246) variable. Direct Trip input and OPEN command also assert TRIP. See Figure 2.24 for information about TRIP output contact operation.
- A1, A2: Select any OR-combination of elements in R1, R2, R3, and R4.
- A3: Select any OR-combination of elements in R1, R3, R4, and R6.
- A4: Select any OR-combination of elements in R2, R3, R4, and R6. Optionally, A4 can operate as an ALARM by placement of jumper JMP3 (the jumper has positions A4 and ALARM).

The CLOSE and ALARM functions have dedicated outputs:

- CLOSE: Asserts by recloser, DC input, or CLOSE command (see Figure 2.25 for an illustration of CLOSE output contact operations).
- ALARM: The ALARM output closes for the following conditions:
  - Three unsuccessful Level 1 access attempts: 1 second pulse
  - Any Level 2 attempt: 1 second pulse
  - Self-test failures: permanent contact closure or 1 second pulse depending on which test fails (see Table 2.5)
  - The ALARM output closes momentarily when relay settings, setting groups, or passwords are changed. It also closes when a date is entered, if the year stored in EEPROM differs from the year entered (see DATE command).

All output relay contacts may be configured as "a" or "b" contacts with soldered wire jumpers JMP4 through JMP11 (each jumper has positions A and B). All relay contacts are rated for circuit breaker tripping duty.

## Viewing Logic Equations

Use the SHOWSET command to print all relay settings including the SELOGIC Control Equations configuration. You can inspect settings in the sample event report in Section 4: EVENT REPORTING.

## SELOGIC Control Equations Settings in Each Setting Group

When you switch groups, you switch logic settings as well as relay element settings. You can program groups for different operating conditions, such as feeder paralleling, station maintenance, seasonal operations, and cogeneration on/off.

## TARGETS

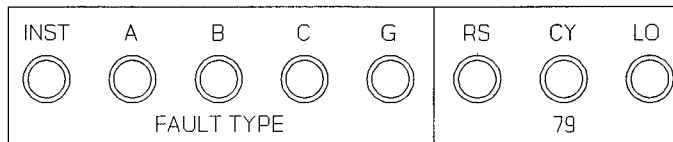
Read targetting information locally by inspecting the LEDs or remotely with the TARGET command and event reports. The TARGET command can access other information as well (see Section 3: COMMUNICATIONS).

The INST target indicates that no overcurrent condition in Relay Word row R1 has been asserted longer than the ITT (instantaneous target time) timer setting before TRIP asserts. This gives you control over what qualifies as a close-in fault. Setting ITT=0 defeats the INST target.

The phase current indicators (A, B, C) show which phases exceed the 51P pickup setting at the time of trip.

The residual current indicator (G) similarly shows if residual current exceeds the 51NP pickup setting at the time of trip.

The last three indicators (RS, CY, and LO) show the state of the reclosing relay (reset, reclose cycle, or lockout).



DWG. 1076-106

**Figure 2.8: SEL-251D-1 Relay Front Panel Target LEDs**

The FAULT TYPE LEDs latch and remain lit until the TRIP output deasserts and one of the following occurs:

- Next trip occurs
- Operator presses front panel TARGET RESET button
- Operator executes TARGET R command

When a new TRIP occurs, the FAULT TYPE LEDs clear, then display and latch the FAULT TYPE targets for the new TRIP condition.

When an operator presses the TARGET RESET button, all eight LEDs illuminate for a one-second lamp test and to indicate that the relay is operational.

## MULTIPLE SHOT RECLOSING RELAY

The four-shot reclosing relay has individual open interval times for each shot and a settable reset interval timer.

If a trip occurs and no reclose cancel condition exists, the relay starts to time on the appropriate open interval (if any remain) when the trip drops out and 52A input deasserts. When the open interval timer expires, the shot counter is incremented and the CLOSE output contact asserts. A close failure timer limits the duration of CLOSE output contact assertion in case 52A does not assert. See Functional Specifications (found in this section) for a description of close failure timer operation. If the close failure timer is not used, the CLOSE output contact remains asserted until 52A asserts.

If the circuit breaker recloses successfully, the reset interval timer starts. Assertion of any element in Relay Word row R1 indicates an overcurrent condition. Detection of an overcurrent condition reinitializes the reset interval timer and inhibits it from timing. When the overcurrent conditions drop out, the reset interval timer starts. When this timer expires, the reclosing relay goes to the reset state (**79RS** = 1) and shot = 0.

Any of the six programmable inputs can be set as a reclose enable (RE) input. If the RE input is de-energized (RE = 0), the relay goes to lockout (**79LO** = 1). When the RE input is de-energized, the CLOSE output contact cannot automatically assert via the reclosing relay.

Another reclose enable input option is !RE. If an input is assigned to the !RE function and the input is energized [**!RE** = NOT(RE) = 1; RE = 0], the relay goes to lockout (**79LO** = 1). When the !RE input is energized, the CLOSE output contact cannot automatically assert via the reclosing relay.

The RE and !RE input options are not reclose initiate functions.

If no input is assigned to the RE or !RE input functions, RE = 1 internally (reclosing is always enabled). If a scheme is set up this way, you can defeat automatic reclosing by setting the first open interval to zero (**79OI1**=0).

One input must be designated either 52A, !52A, 52AR, or !52AR. Otherwise, automatic reclosing and other close operations using the CLOSE output contact are unavailable (CLOSE Command, Direct Close).

The number of non-zero open interval time periods determines available reclosing shots (four shots maximum). The Relay Word bit **79SH** can assert (**79SH** = 1) for different shots, 0 through 4. For example, if you only want **79SH** to assert for shots 0 and 1, enter the following setting:

**M79SH = 11000**



79SH can be used to supervise overcurrent elements and reclose cancel conditions.

Reclosing relay timing accuracy is  $\pm 1$  cycle.

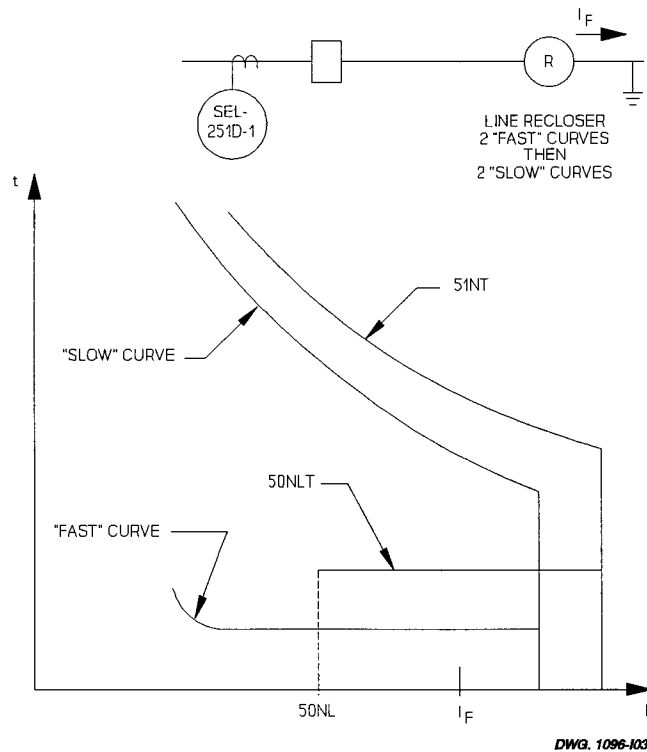
### Reclose Cancel Conditions

The internal reclose cancel variable RC(1246) can be set to equal any OR-combination of elements in Relay Word rows R1, R2, R4, and R6. Reclosing is also cancelled if:

- An input assigned to RE (reclose enable) is not asserted (or an input assigned to !RE is asserted),
- An input assigned to DT (direct trip) is asserted,
- The CF (close fail) condition occurs, or
- The OPEN command is enabled and executed.

### Sequence Coordination

To keep in step with line reclosers, the reclosing relay includes sequence coordination. Sequence coordination can prevent overreaching relay overcurrent elements from tripping for faults beyond line reclosers. A sequence coordination example follows.



**Figure 2.9: Sequence Coordination, Ground/Residual Overcurrent Elements**

A partial setting list is given:

$$M79SH = 11000 \quad (79SH = 1 \text{ for only shot} = 0 \text{ and } 1)$$

Using SELOGIC Control Equations:

$$\begin{aligned} B(12) &= 50NLT \\ G(34) &= 79SH \\ X(56) &= B * G \\ TR(1246) &= 51NT + X \quad (\text{effectively, } TR(1246) = 51NT + (50NLT * 79SH)) \\ SEQ(1) &= 50NL \end{aligned}$$

$$\begin{aligned} \text{close TRIP output contacts} &= TR + \dots \\ &= 51NT + 50NLT * 79SH + \dots \end{aligned}$$

The M79SH setting selects for which shots (0, 1, 2, 3, or 4) the 79SH bit is asserted (79SH = 1). 79SH supervises 50NLT for tripping. 50NL is the pickup for 50NLT.

The SEQ(1) variable can be set to any OR-combination of elements in Relay Word row R1. The combination you select determines which overcurrent conditions control sequence coordination. If the circuit breaker is closed and the TRIP output contacts are not asserted, SEQ(1) increments the reclosing relay shot counter every time SEQ(1) goes from the state SEQ(1) = 1 to SEQ(1) = 0.

The SEL-251D-1 Relay is reset (79RS = 1, shot = 0) and has four open intervals set (four shots to lockout).

In the example, a permanent ground fault greater than 50NL in magnitude occurs beyond the line recloser. Because 50NLT and the line recloser fast curve are properly coordinated, the line recloser operates twice on its fast curve and the SEL-251D-1 Relay doesn't trip. After operating on two fast curves, the line recloser disables its fast curve and operates on its slow curve.

During the two line recloser fast curve operations, the 50NL element picked up and dropped out twice without the SEL-251D-1 Relay tripping. Because SEQ(1) = 50NL, the shot counter incremented twice, so shot = 2. Every time SEQ(1) increments the shot counter, the reset interval timer is reinitialized.

Because 79SH = 1 for shots 0 and 1 only, 50NLT is now disabled at shot = 2. 50NLT will remain cut out until the newly reinitialized reset interval timer expires. The line recloser then operates on its two slow curves, causing the relay shot counter to increment to shot = 4. The line recloser then goes to lockout. When the SEL-251D-1 Relay reset interval timer expires, shot = 0 again.

Sequence coordination prevents the SEL-251D-1 Relay from tripping for a fault beyond a line recloser. However, proper coordination was present between the line recloser fast curve and 50NLT in this example.

No phase overcurrent elements were enabled for tripping in this example. This is usually not the case in practice but was done to simplify the example.

## SELECTABLE SETTING GROUPS

The relay accepts six groups of relay and logic settings.

Program relay elements and logic with the SET command. To program group 1 settings and logic, use SET 1 and provide the requested information. The COPY command makes it easy to copy settings and logic from one group to another (e.g., **COPY 1 4** copies Group 1 to Group 4). Afterward, you can edit Group 4 settings and logic with the SET command.

The relay determines which group of settings and logic to use by monitoring the setting group selection inputs (SS1, SS2, and SS3). To use inputs, program one or more of the setting selection inputs SS1, SS2, and SS3 to the respective inputs IN1, IN2, and IN3. You can also use the GROUP command to specify a setting group.

**Table 2.3: Setting Group Selection Input Truth Table**

SS3	SS2	SS1	
0	0	0	GROUP Command Selection
0	0	1	Group 1
0	1	0	Group 2
0	1	1	Group 3
1	0	0	Group 4
1	0	1	Group 5
1	1	0	Group 6
1	1	1	GROUP Command Selection

If SS1, SS2, or SS3 is not assigned to an input, it defaults to 0. If no inputs are assigned as setting group selection inputs the GROUP command entry controls group selection. With only SS1 assigned, GROUP command selection determines settings to use if the input assigned to SS1 is not asserted. If the input is asserted, setting Group 1 is used.

For example, to switch between Group 1 and Group 5, program input IN1 to SS1 and use the GROUP command to select Group 5. With IN1 asserted, the relay uses Group 1. With IN1 deasserted, it uses Group 5.

When the status of any assigned setting group selection input changes, the relay waits a settable time period (TGR) for inputs to stabilize before changing the active setting group. Thus, if a setting group selection input status changes and reverts to its previous state before TGR expires, the relay does not change the active setting group. The TGR setting is one of several global settings and is entered with the SET G command.

Active setting group changes (via setting group selection inputs or GROUP command) disable the relay for less than 0.5 seconds to allow loading of new active settings. The ALARM output contacts close during this time and all timers and relay elements reset.

The DEMR setting allows you to specify whether or not demand values for current, MW, and MVAR are reset when the active setting group changes. The relay resets demand values as it would for METER RD execution. The following example illustrates a situation when you should reset demand values.

You might want to change the active setting group for distribution feeder switching where significant load is removed from the feeder. If the new active setting group has lower demand current thresholds (PDEM and NDEM settings) than the previous active setting group, the corresponding PDEM and NDEM demand ammeter threshold bits could assert. This is because the respective demand ammeters have not yet adjusted to the lower loading level, as dictated by the relatively long demand ammeter time constant (setting DATC = 5 - 60 minutes). If PDEM and NDEM are assigned to programmable output contacts (A1 - A4), a false alarm would result. To overcome this problem, set DEMR = Y. With this setting, the relay resets demand values to zero when the active setting group changes.

The DEMR setting is entered with the SET G command. See Section 3: COMMUNICATIONS for more details on the SET, COPY, GROUP, and METER RD commands.

## CIRCUIT BREAKER MONITOR

The SEL-251D-1 Relay detects every circuit breaker trip operation. It designates each trip as one caused by the relay or an external device and maintains a running count of each.

The relay also maintains a running sum of the interrupted current in each circuit breaker pole for relay and external trips. Running sums for relay trips use the current present one cycle after the trip output contacts assert. Running sums for external trips use the currents present when the circuit breaker status input indicates that the circuit breaker has opened.

You can access the circuit breaker operation data using the BREAKER commands. See Section 3: COMMUNICATIONS for more details on these commands.

## METERING

The SEL-251D-1 Relay provides complete voltage and current metering. It also determines real and reactive power values, demand values, peak demand values, and zero-sequence current.

You can access and reset metering data using different METER commands. See Section 3: COMMUNICATIONS for more information.

## SERIAL INTERFACES

Port 1 and Port 2 are EIA RS-232-C serial data interfaces.

Port 1 is located on the rear panel and is generally used for remote communications via a modem or the SEL-PRTU.

Port 2 has connectors on both the front and rear panels, designated Port 2F and Port 2R, respectively. Port 2F has priority over Port 2R. These ports are generally used for local communications. Port 2R is typically connected to a printer, SEL-RD, or SEL-DTA. Port 2F is typically used for temporary communications via a portable terminal.

When a device is plugged into Port 2F, the relay automatically begins addressing Port 2F and discontinues communication with Port 2R. When a device unplugged from Port 2F, the relay automatically resumes communication with the device connected to Port 2R.

The baud rate of each port is set by jumpers near the front of the main board. You can access these jumpers by removing either the top cover or front panel. Available baud rates are 300, 600, 1200, 2400, 4800, or 9600.

The serial data format is:

- Eight data bits
- Two stop bits (-E2 model) or one stop bit (-E1 model)
- No parity

The serial communications protocol and port pin definitions appear in Section 3: COMMUNICATIONS.

## SELF-TESTS

The relay runs a variety of self-tests. Some tests have warning and failure states, others only have failure states. The relay generates a status report after any change in self-test status.

The relay closes the ALARM contacts after any self-test fails. When it detects certain failures, the relay disables the breaker control functions and places its output driver port in an input mode. No outputs may be asserted when the instrument is in this configuration. The relay runs all self-tests on power up and before enabling new settings. During normal operation, it performs self-tests at least every few minutes.

## Offset

The relay measures the offset voltage of each analog input channel and compares the value against fixed limits. It issues a warning when offset is greater than 50 millivolts in any channel and declares a failure when offset exceeds 75 millivolts. The offset levels of all channels appear in the STATUS command format.

## Power Supply

Power supply voltages are limit-checked. The table below summarizes voltage limits.

<u>Supply</u>	<u>Warning Thresholds</u>		<u>Failure Thresholds</u>	
+5 V	+5.3 V	+4.7 V	+5.4 V	+4.6 V
+15 V	+15.8 V	+14.2 V	+16.2 V	+13.8 V
-15 V	-15.8 V	-14.2 V	-16.2 V	-13.8 V

The relay transmits a STATUS message for any self-test failure or warning. A +5 volt supply failure de-energizes all output relays and blocks their operation. A  $\pm 15$  volt supply failure disables protective relay functions while control functions remain intact. The ALARM relay remains closed after a power supply failure.

## Random-Access Memory

The relay checks random-access memory (RAM) to ensure that each byte can be written to and read from. There is no warning state for this test. If the relay detects a problem, it transmits a STATUS message with the socket designation of the affected RAM IC. A RAM failure disables protective and control functions and closes the ALARM output relay contacts.

## Read-Only Memory

The relay checks read-only memory (ROM) by computing a checksum. If the computed value does not agree with the stored value, the relay declares a ROM failure. It transmits a STATUS message with the socket designation of the affected ROM IC. A ROM failure disables protective and control functions and closes the ALARM output relay contacts.

**Analog-to-Digital Converter**

The analog-to-digital converter (ADC) changes voltage signals derived from power system voltages and currents into numbers for processing by the microcomputer. The ADC test verifies converter function by checking conversion time. The test fails if conversion time is excessive or a conversion starts and never finishes. There is no warning state for this test. While an ADC failure disables protective functions, control functions remain intact. The relay transmits a STATUS message and closes the ALARM relay contacts.

**Master Offset**

The master offset (MOF) test checks offset in the multiplexer/analog to digital converter circuit. A grounded input is selected and sampled for dc offset. The warning threshold is 50 mV; failure threshold is 75 mV. A failure pulses the ALARM contact closed for one second. The relay transmits a STATUS message for both warning and failure conditions.

**Settings**

The relay stores two images of the system settings in nonvolatile memory. The test compares them when the relay is initially set and periodically thereafter. If the images disagree, the setting test fails and the relay disables all protective and control functions. It transmits the STATUS message to indicate a failed test. The ALARM relay remains closed after a setting failure.

Table 2.5 shows relay actions for any self-test condition: warning (W) or failure (F).

<b>Table 2.5: Self-Test Summary</b>					
<u>Self-Test</u>	<u>Limits</u>	<u>Status Message</u>	<u>Protection Disabled</u>	<u>Control Disabled</u>	<u>Alarm Output</u>
RAM	---	F	YES	YES	permanent contact assertion
ROM	---	F	YES	YES	permanent contact assertion
SETTINGS	---	F	YES	YES	permanent contact assertion
A/D	---	F	YES	NO	permanent contact assertion
+5 V	$\pm 0.3$ V	W	NO	NO	no ALARM contact assertion
	$\pm 0.4$ V	F	YES	YES	permanent contact assertion
$\pm 15$ V	$\pm 0.8$ V	W	NO	NO	no ALARM contact assertion
	$\pm 1.2$ V	F	YES	NO	permanent contact assertion
CHANNEL	50 mV	W	NO	NO	no ALARM contact assertion
OFFSETS	75 mV	F	NO	NO	one second contact pulse
MASTER	50 mV	W	NO	NO	no ALARM contact assertion
OFFSET	75 mV	F	NO	NO	one second contact pulse

## IRIG-B INPUT DESCRIPTION

The port labeled J201/AUX INPUT receives demodulated IRIG-B time code input. The IRIG-B input circuit is a 56 ohm resistor in series with an opto-coupler input diode. The input diode has a forward drop of about 1.5 volts. Driver circuits should put approximately 10 mA through the diode when "on."

The IRIG-B serial data format consists of a one second frame containing 100 pulses and divided into fields. The relay decodes second, minute, hour, month, and day fields and sets the relay clock accordingly.

When IRIG-B data acquisition is activated either manually (with the IRIG command) or automatically, the relay reads two consecutive frames. It updates the older frame by one second and compares the frames. If they do not agree, the relay considers the data erroneous and discards it.

The relay reads the time code automatically about once every five minutes. It stops IRIG-B data acquisition ten minutes before midnight on New Year's Eve so the relay clock can implement the year change without interference from the IRIG-B clock.

## SIGNAL PROCESSING

The relay low-pass filters all analog input channels to remove high frequency components. Next it samples each channel four times per power system cycle. After low-pass filtering, the relay digitally filters each sample with the CAL digital filter method. The CAL filter eliminates dc offset and reduces the decaying exponential offset that may be present on the input signal following a fault.

The digital filter has the properties of a double differentiator smoother and requires only addition and subtraction of data samples. Let the latest four samples of one channel be X1, X2, X3, and X4. Then the digital filter is defined:

$$P = X1 - X2 - X3 + X4.$$

This filter eliminates dc offsets. When all samples are set to the same value, the filter output is zero. It also eliminates ramps, which you may verify by setting the samples equal to 1, 2, 3, and 4. Again, the output is zero.

Every quarter-cycle, the relay computes a new value of P for each input. The current value of P combines with the previous value (renamed Q) to form a Cartesian coordinate pair. This pair represents the input signal as a phasor (P, Q). The relay processes these phasor representations of the input signals.



## TORQUE CONTROL

Elements in Relay Word row R1 may be torque controlled. Elements derived from row R1 elements are torque controlled if the row R1 element is torque controlled. For example, if row R1 elements **51P** and **50NL** are torque controlled, row R2 elements **51T** and **50NLT** are also torque controlled. **51P** and **50NL** are the pickups for **51T** and **50NLT**, respectively. See Figures 2.18, 2.19, and 2.20 for more information.

Phase overcurrent elements can be externally and internally torque controlled. Ground/residual overcurrent elements can only be externally torque controlled.

### External Torque Control

The ETC(1) setting selects overcurrent elements to be externally torque controlled. Only overcurrent elements in Relay Word row R1 can be selected. As an example:

ETC = **51P, 50NL**    **51P, 50NL**, and consequently **51T** and **50NLT** are selected for external torque control

TCP    External Torque Control (Phase Overcurrent Elements)

TCG    External Torque Control (Ground/Residual Overcurrent Elements)

TCP and TCG are assigned to programmable inputs. The inverted sense of TCP or TCG is available, too (!TCP or !TCG, respectively).

If input IN3 = TCP, the phase overcurrent elements selected in the ETC(1) setting (**51P** and consequently **51T** in this example) are enabled for operation when input IN3 is energized. If input IN3 = !TCP, the phase overcurrent elements selected in the ETC(1) setting are enabled for operation when input IN3 is de-energized.

If neither TCP or !TCP is assigned to an input, the phase overcurrent elements selected in the ETC(1) setting are not externally torque controlled. The selected phase overcurrent elements are always enabled with respect to external torque control.

If input IN4 = TCG, the ground/residual overcurrent elements selected in the ETC(1) setting (**50NL** and consequently **50NLT** in this example) are enabled for operation when input IN4 is energized. If input IN4 = !TCG, the ground/residual overcurrent elements selected in the ETC(1) setting are enabled for operation when input IN4 is de-energized.

If neither TCG nor !TCG is assigned to an input, the ground/residual overcurrent elements selected in the ETC(1) setting are not externally torque controlled. The selected ground/residual overcurrent elements are always enabled with respect to external torque control.

## Internal Torque Control

The ITC(1) setting selects phase overcurrent elements to be internally torque controlled. Only phase overcurrent elements in Relay Word row R1 can be selected. As an example:

ITC = **51P, 50H**      **51P, 50H**, and consequently **51T** are selected for internal torque control

The TCI setting selects the elements which perform internal torque control:

TCI = 0, V, I, or 3    0 = none, V = **27**, I = **50C**, 3 = both

If you set TCI equal to V, the **27** element torque controls phase overcurrent elements selected in the ITC(1) setting (**51P** and **50H** and consequently **51T** in this example). If **27** asserts, the selected phase overcurrent elements are enabled with respect to internal torque control.

If you set TCI equal to I, the **50C** element torque controls phase overcurrent elements selected in the ITC(1) setting (**51P** and **50H** and consequently **51T** in this example). If **50C** asserts, the selected phase overcurrent elements are enabled with respect to internal torque control.

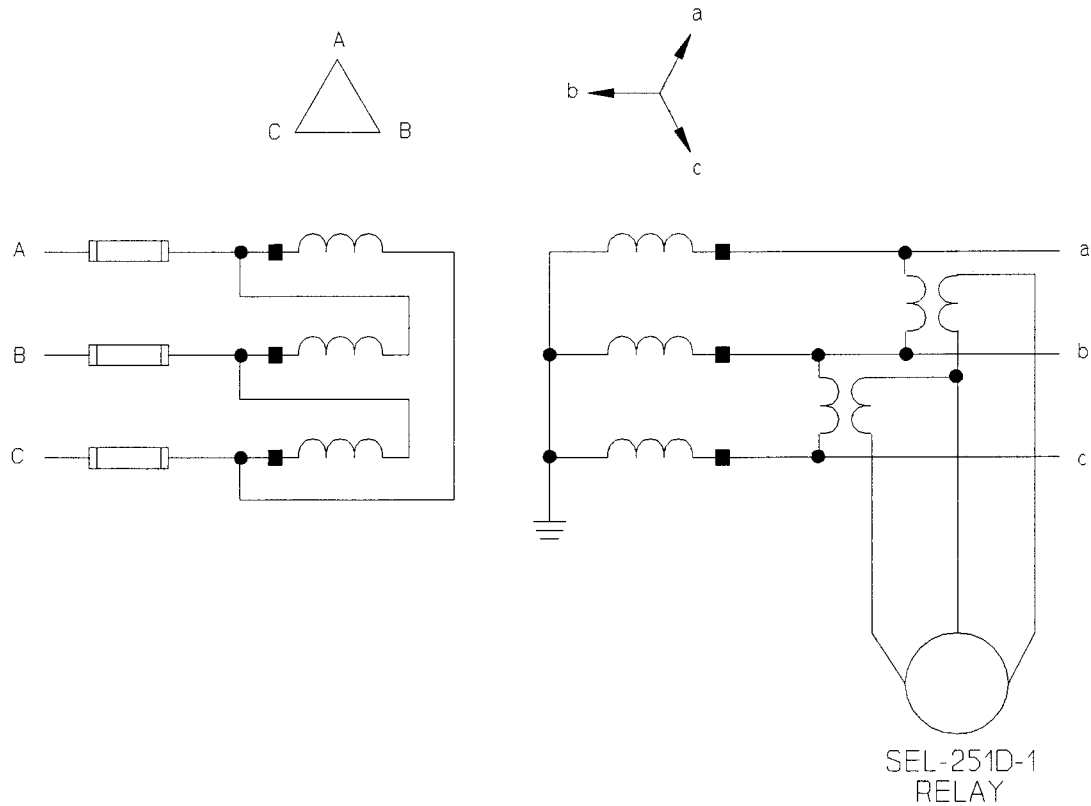
If you set TCI equal to 3, the phase overcurrent elements selected in the ITC(1) setting (**51P** and **50H** and consequently **51T** in this example) are torque controlled by "**27 + 50C**". If either **27** or **50C** asserts, the selected phase overcurrent elements are enabled with respect to internal torque control.

If you set TCI equal to 0, the phase overcurrent elements selected in the ITC(1) setting (**51P** and **50H** and consequently **51T** in this example) are not internally torque controlled. The phase overcurrent elements are always enabled with respect to internal torque control.

## Transformer Blown-Fuse Detection

Delta-wye connected distribution transformer banks are frequently protected by fuses connected in the bank high side, as shown in Figure 2.10. When one high-side fuse blows, unbalanced voltages are applied to the transformer bank and its connected load.

The SEL-251D-1 Relay includes logic that detects high-fuse operations by measuring the low-side voltages. The logic also rejects operations of low-side Voltage Transformer (VT) fuses.



**Figure 2.10: Distribution Transformer Bank Protected by High-Side Fuses**

**What Happens When a High-Side Fuse Blows?**

When a transformer high-side fuse operates, the low-side phase-to-phase voltage magnitudes drop. One phase-to-phase voltage magnitude goes to zero, and the remaining two drop to 0.87 per unit of nominal voltage. If two high-side fuses operate, the low-side phase-to-phase voltages all go to zero.

If a VT secondary fuse blows while the transformer bank is otherwise operating normally, two of the phase-to-phase voltages presented to the relay drop to 0.58 per unit of nominal. If two VT secondary fuses operate, one phase-to-phase voltage measured by the relay goes to zero while the other two drop to 0.58 per unit.

With these facts in mind, the logic described below is easy to understand.

## How Does the SEL-251D-1 Relay Detect Transformer Fuse Operations?

When the relay setting  $27C=4$ , the 27 phase-to-phase undervoltage logic detects high-side fuse operations. To use the relay undervoltage logic in this application, make the following relay setting calculations:

$$\begin{aligned}27L &= 0.40 \cdot V_{nom} \\27H &= 0.72 \cdot V_{nom} \\27C &= 4\end{aligned}$$

where:

$V_{nom}$  = Nominal Phase-to-Phase Voltage, V secondary

The setting option,  $27C = 4$ , enables the following logic for the **27** Relay Word bit:

$$27 = (\text{Any phase-to-phase voltage less than } 0.4 \text{ pu}) * (\text{Any phase-to-phase voltage greater than } 0.72 \text{ pu})$$

$$27 = (27LAB + 27LBC + 27LCA) * (!27HAB + !27HBC + !27HCA)$$

If a transformer fuse operates, one phase-to-phase voltage goes to zero (satisfying the left portion of the equation above) and the remaining phase-to-phase voltages stay above 0.72 per unit (satisfying the right portion of the equation). If a VT fuse operates, the phase-to-phase voltages drop below the 0.72 per unit threshold and the **27** equation is not satisfied.

## Use the Detection Logic to Trip or Indicate

Since certain faults may also present these voltages to the SEL-251D-1 Relay, you may wish to use a nondedicated SELOGIC Control Equation timer, such as the **ST** timer to provide some coordinated time delay on pickup of the condition.

Set the SELOGIC Control Equation,  $S(123) = 27$ . Use the time-delayed pickup timer,  $TSPU = 300$  to  $600$  cycles to provide a 5- to 10-second time delay. You can use the **ST** bit, which includes the time-delayed pickup, in any of the SELOGIC Control Equations for tripping or programmable output contact operation.

## DEMAND AMMETERS

The SEL-251D-1 Relay provides demand ammeters for phase and zero-sequence (ground/residual) currents. Peak demands are saved. The demand ammeters behave much like low-pass filters, responding to gradual trends. The demand ammeter time constant is used for all three demand ammeters. The time constant is settable from 5 to 60 minutes.

Figure 2.23 shows the phase and ground/residual demand ammeters from top to bottom. Let's concentrate on the bottom diagram (ground/residual demand ammeter) to understand demand ammeter functions in general.

Present ground/residual current ( $IR$ ) is the input into the ground/residual demand ammeter and ground/residual demand current ( $ND(t)$ ) is the output. If the ground/residual demand current is  $ND(0)$  at  $t=0$  and the ground/residual current ( $IR$ ) is constant, at  $t=DATC$  the ground/residual demand current will be:

$$ND(DATC) = 0.9(IR - ND(0)) + ND(0) = 0.9IR + 0.1ND(0)$$

If the ground/residual demand current was reset at  $t=0$  ( $ND(0) = 0$ ), at  $t=DATC$  the ground/residual demand current would be:

$$ND(DATC) = 0.9(IR)$$

For all demand ammeters in general, if demand current is reset at  $t=0$  and a constant input current is applied, the demand current output will be 90% of the constant input current value at  $t=DATC$ .

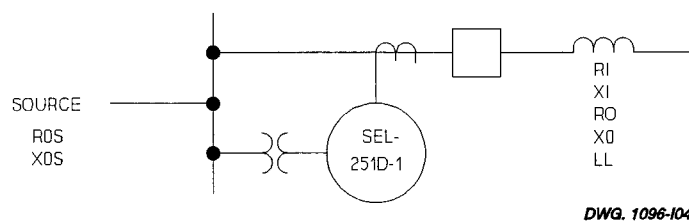
Settable demand ammeter thresholds are available for all three demand ammeters in units of amps secondary. The thresholds are  $PDEM$  and  $NDEM$  for the phase and ground/residual demand ammeters, respectively.

If demand currents exceed a threshold, the respective Relay Word bit  $PDEM$  or  $NDEM$  is asserted. These Relay Word bits can alarm for phase overload or residual current unbalance and can warn of impending overcurrent relay pickup and timing to trip due to such overload and unbalance conditions.

## FAULT LOCATOR

The fault locator operates only if an event report is triggered and at least one of the over-current element pickups in Relay Word row R1 is picked up. To disable the fault locator, set line length ( $LL$ ) to 0.001.

The following parameters in Figure 2.11 are used for fault locating.



**Figure 2.11: Source and Line Impedances**

The resistive and reactive impedances (R0S, R1, R0 and X0S, X1, X0, respectively) are set in units of ohms primary.

The R0S and X0S zero-sequence source impedance settings allow the zero-sequence voltage to be derived and used for fault locating.

The positive- and zero-sequence primary line impedance values (R1, X1 and R0, X0, respectively) correspond to a line length (LL). The LL setting does not have specified units, which allows the use of any unit of measure (miles, km, feet, etc.). The algorithm assumes that negative-sequence line impedance equals positive-sequence line impedance.

The actual fault location algorithm is composed of two steps. First the relay determines fault type, then it calculates location.

The relay determines fault type independently of relay element operations. Fault type determination is based on a phase current magnitude comparison.

Compared currents are taken from two rows at the middle of the stored fault data. If uncompensated current magnitudes are in large ratios between phases (4:1 or more), fault type becomes immediately apparent as single- or two-phase. If not, the same current is load compensated by the two corresponding prefault current rows in the first cycle of the event report.

If these fault current component magnitudes are in moderate ratios (1.5:1 or more), the relay lists a single- or two-phase fault. If all ratios are less than 1.5, the relay lists a three-phase fault. Explicit fault classification logic is as follows, where "I" values are uncompensated midfault currents and "If" values are midfault currents compensated for load, yielding true fault current components:

```
IF (Imax > 4 x Imed) THEN Single-phase
ELSE IF (Imed > 4 x Imin) THEN Two-phase
ELSE IF (Ifmax > 1.5 x Ifmed) THEN Single-phase
ELSE IF (Ifmed > 1.5 x Ifmin) THEN Two-phase
ELSE IF (none of the above) THEN Three-phase
```

This algorithm is largely immune to load and system grounding variations.

Once the relay determines fault type, the fault locator uses the Takagi algorithm to locate the fault. Using prefault and fault data, it compensates for errors introduced by fault resistance in the presence of load flow. If the event record contains no sound prefault data, the relay gives a location based on a simple reactance measurement.

The fault locator depends on accurate distribution source and line parameters and instrument transformer ratios. Pay special attention to these potential sources of difficulty:

- Instrument transformer errors due to overburden by other devices
- Capacitive potential transformer capacitor value
- Distribution source and line parameter errors

Although the fault location computation takes several seconds, the relay can handle several faults in quick succession. The relay stores all fault data, then processes each fault in turn. For example, suppose three faults occur within a few seconds. The relay stores data from them as they occur. The fault location computations begin with the first (oldest) fault and proceed until all three fault records are processed. The relay transmits each summary event report when the corresponding fault location is available.

The relay locates phase-to-ground faults even though it measures phase voltages. It uses an estimate of the zero-sequence voltage, since no measurement is available from the measured line-to-line voltages. It does this from the product of the zero-sequence source impedance and the measured zero-sequence current.

The voltage  $V_A$  is determined for an A-phase to ground fault as follows:

$$V_A = V_1 + V_2 + V_0 \text{ and } V_1 + V_2 = 1/3 [ V_{AB} - V_{CA} ]$$

$$V_A = 1/3 [ V_{AB} - V_{CA} ] + V_0$$

where  $V_1$  is the positive-sequence voltage,  $V_2$  is the negative-sequence, and  $V_0$  is the zero-sequence voltage. This is easily shown by rewriting the equation:

$$V_A = 1/3 [ V_A - V_B + V_A - V_C ] + 1/3 [ V_A + V_B + V_C ]$$

The zero-sequence voltage is therefore the component needed to reconstruct  $V_A$ , given only the line-to-line input voltages. Although it is unavailable in the line-to-line voltage measurements, it may be computed as follows:

$$V_0 = - [ Z_{0S} \times I_0 ]$$

where  $Z_{0S}$  is the zero-sequence source impedance, and  $I_0$  is the zero-sequence current.

Therefore, the computed value for A-phase voltage is:

$$V_A = 1/3 [ V_{AB} - V_{CA} ] - [ Z_{0S} \times I_0 ]$$

The constant  $Z_{0S}$  is a complex number that is entered in the SET command as  $R_{0S}$  and  $X_{0S}$ .

The relay does not consider shunt capacitance of a line. The capacitance causes the fault location to appear more remote by a factor of approximately  $1/\cos(bL)$ , where  $bL$  is the line length in radians. One wavelength at 60 Hz is 3100 miles. For example, the line length of a 100 mile line in radians is calculated:

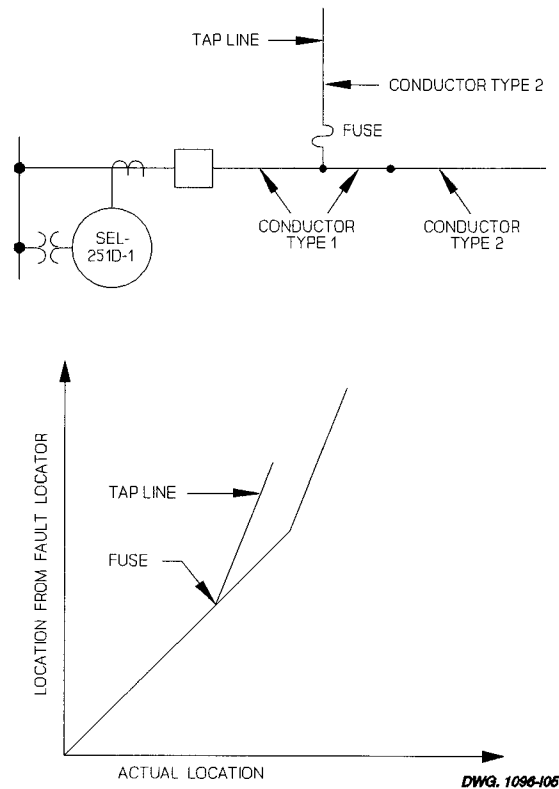
$$(100/3100)(2)(3.14159) = 0.2027 \text{ radians}$$

The indication neglecting capacitance is about  $\cos(0.2027) = 0.98$  times the actual location, or about two miles short for a fault at the far end of a 100 mile line.

When a station uses shunt reactor compensation and the relay is connected to measure reactor plus line current, the shunt reactors reduce fault locating error due to shunt capacitance.

## Nomographs

The relay fault locator is designed for circuits having a constant per-unit length impedance. This is often the case with transmission lines. However, distribution lines often have conductor changes, resulting in different per-unit length impedances. Nomographs are used to compensate for these changes. Fault studies are run for different fault locations on the distribution system. Relay location voltage and current information is taken from the fault study and applied to the relay. The resultant fault location from the relay fault locator is shown on the nomograph with respect to the actual location.



**Figure 2.12: Nomograph for Fault Locating**

## EVENT REPORT

The event report displays current and voltage quantities in primary units. The relay encodes relay element states, outputs, and inputs using a simple process, making the report compact and easy to interpret. Use the **EVENT** command to access the eleven cycle event reports. Use the **HISTORY** command to list summary event reports. See Section 3: **COMMUNICATIONS** for more information on these commands.



## **Event Report Triggering**

Set the variable ER(1246) to any OR-combination of elements in Relay Word rows R1, R2, R4, and R6 to trigger an event report for any desired combination of conditions the relay can detect. Event reports also trigger for:

- Any TRIP output
- Assertion of an input assigned to the ET function
- TRIGGER command execution

See Section 4: EVENT REPORTING for more information on event reports.

## TIME-OVERCURRENT ELEMENT CURVE-TIMING AND TIME DELAY RESET EQUATIONS

The following time-overcurrent equations are applicable to the phase and ground/residual time-overcurrent elements.

There are two reset characteristic choices for the phase and ground/residual time-overcurrent elements via the 51RS, 51GRS, and 51NRS settings, respectively. One choice resets the elements if current drops below pickup for at least one cycle. The other choice (time delay reset) emulates electromechanical induction disc elements, where the reset time depends on the time dial setting, the percentage of disc travel, and the amount of current between zero and pickup. The time delay reset equations ( $t_r = \dots$ ) are given below.

- $t_M$  = curve operating time in seconds
- $t_r$  = reset time in seconds (for time delay reset)
- $TD$  = time dial setting
- $M$  = multiples of pickup. For curve operating time ( $t_M$ ),  $M > 1$ .  
For reset time ( $t_r$ ),  $M \leq 1$ .

Curve 1: Moderately Inverse - see Figure 2.13

$$t_M = TD \left[ 0.157 + \frac{0.668}{M-1} \right] \qquad t_r = \frac{TD}{0.949 - 0.936M}$$

Curve 2: Inverse - see Figure 2.14

$$t_M = TD \left[ 0.180 + \frac{5.95}{M^2-1} \right] \qquad t_r = \frac{TD}{0.172 - 0.168M}$$

Curve 3: Very Inverse - see Figure 2.15

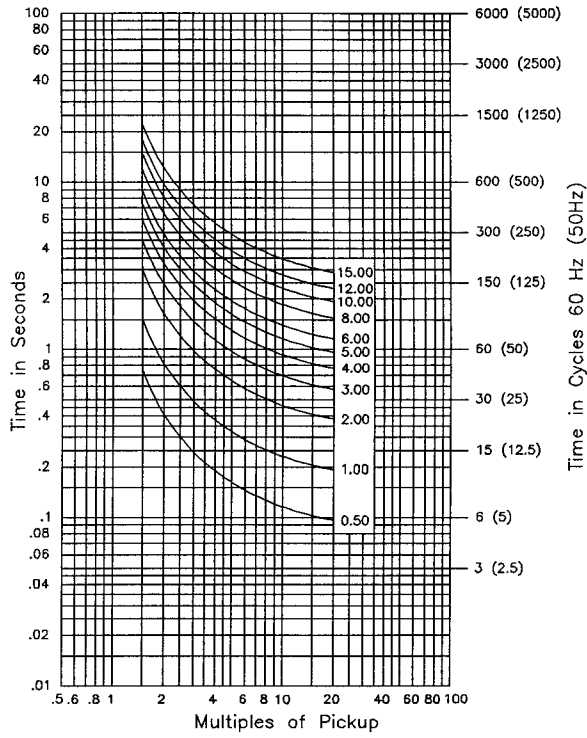
$$t_M = TD \left[ 0.0963 + \frac{3.88}{M^2-1} \right] \qquad t_r = \frac{TD}{0.246 - 0.240M}$$

Curve 4: Extremely Inverse - see Figure 2.16

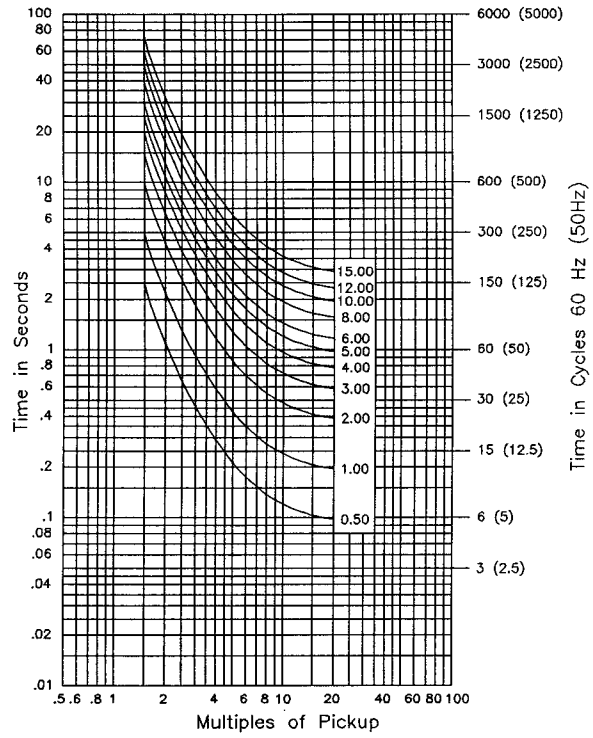
$$t_M = TD \left[ 0.0352 + \frac{5.67}{M^2-1} \right] \qquad t_r = \frac{TD}{0.194 - 0.192M}$$

Curve 5: Short-time Inverse - see Figure 2.17

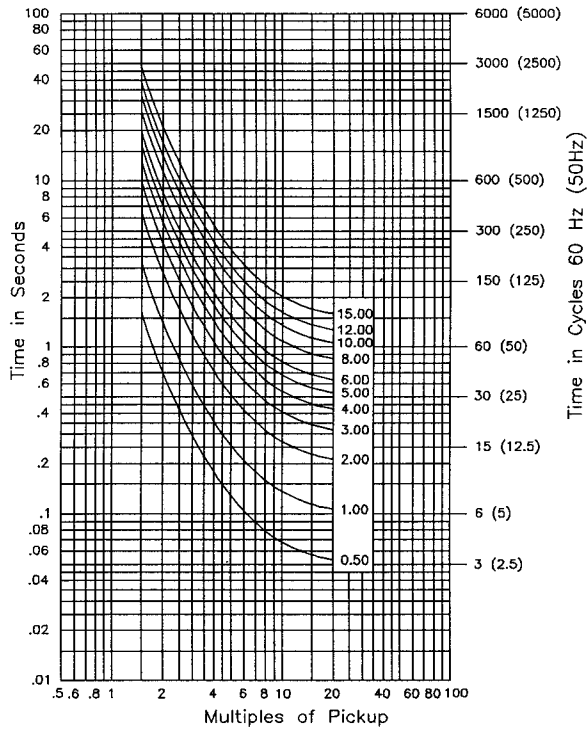
$$t_M = TD \left[ 0.00262 + \frac{0.00342}{M^{0.02}-1} \right] \qquad t_r = \frac{TD}{2.891 - 2.824M}$$



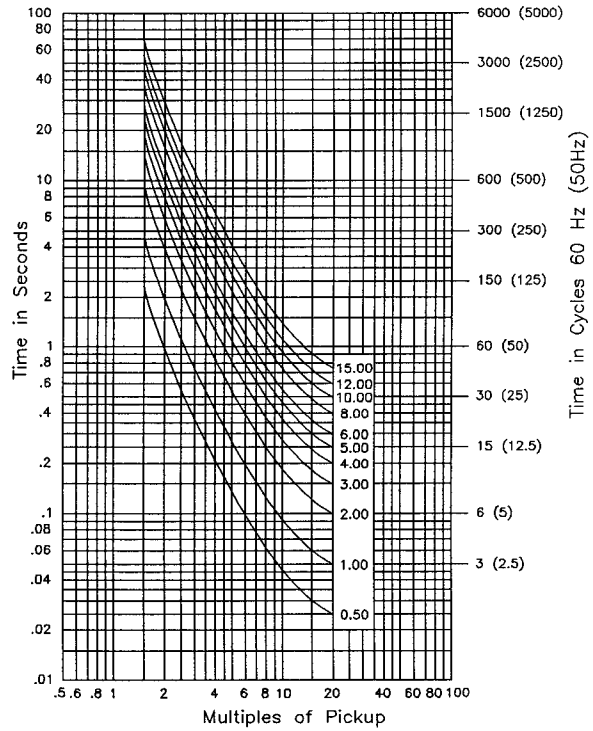
**Figure 2.13: Moderately Inverse Curves**



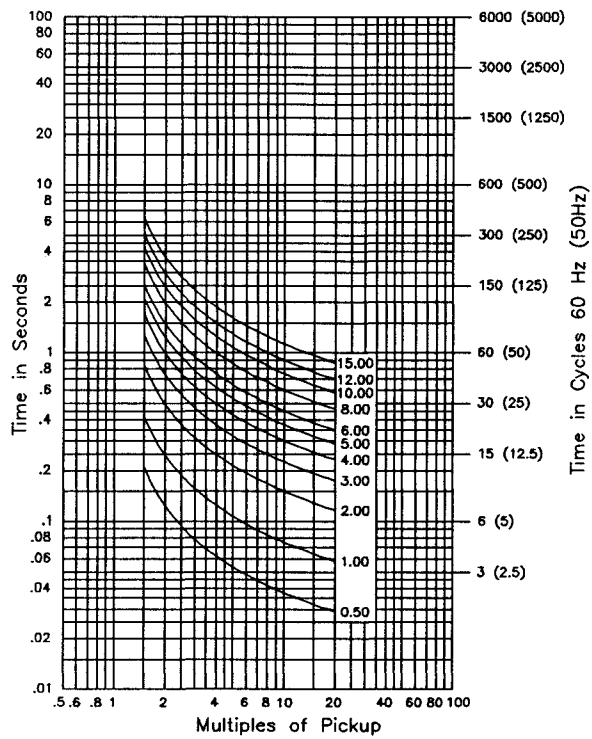
**Figure 2.14: Inverse Curves**



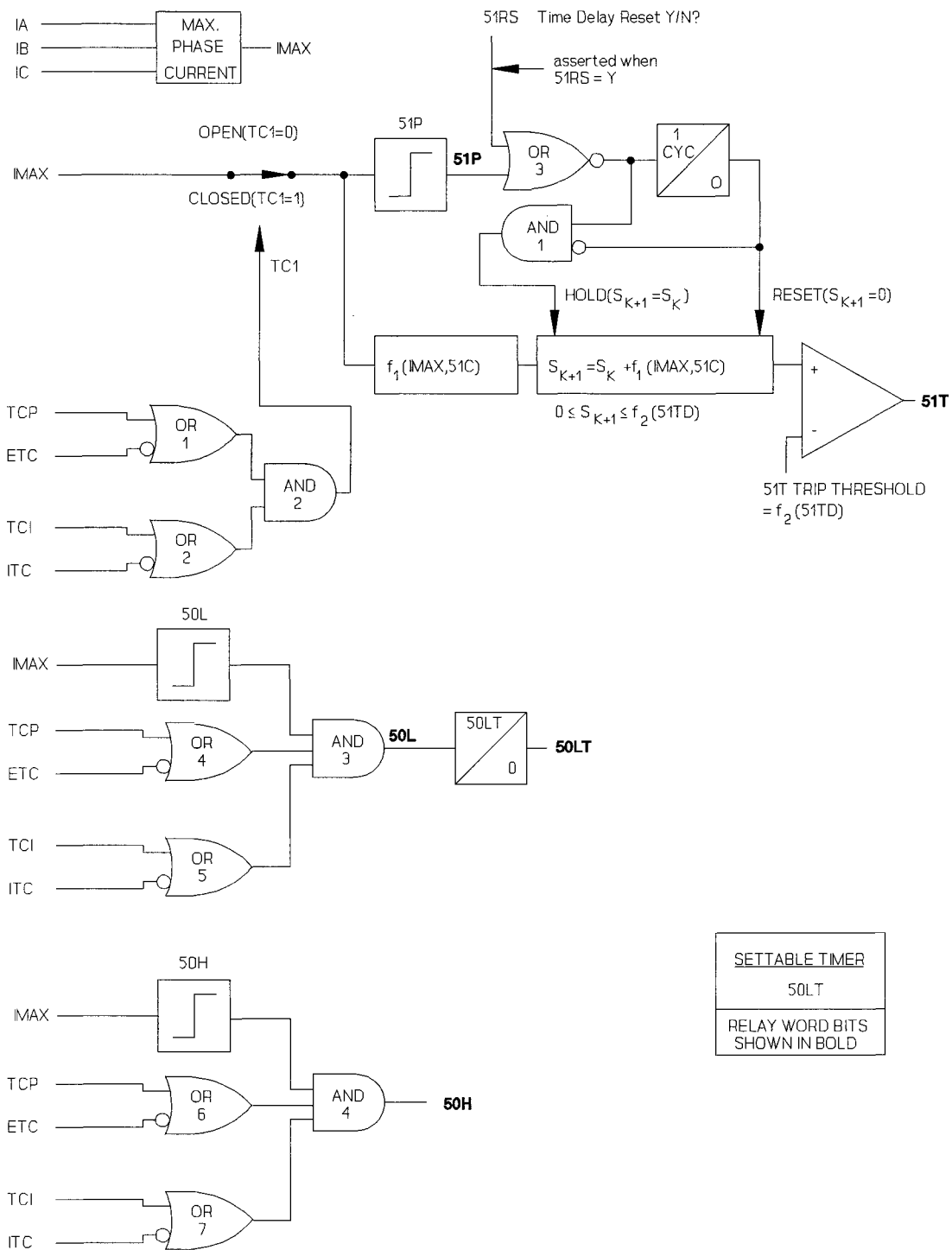
**Figure 2.15: Very Inverse Curves**



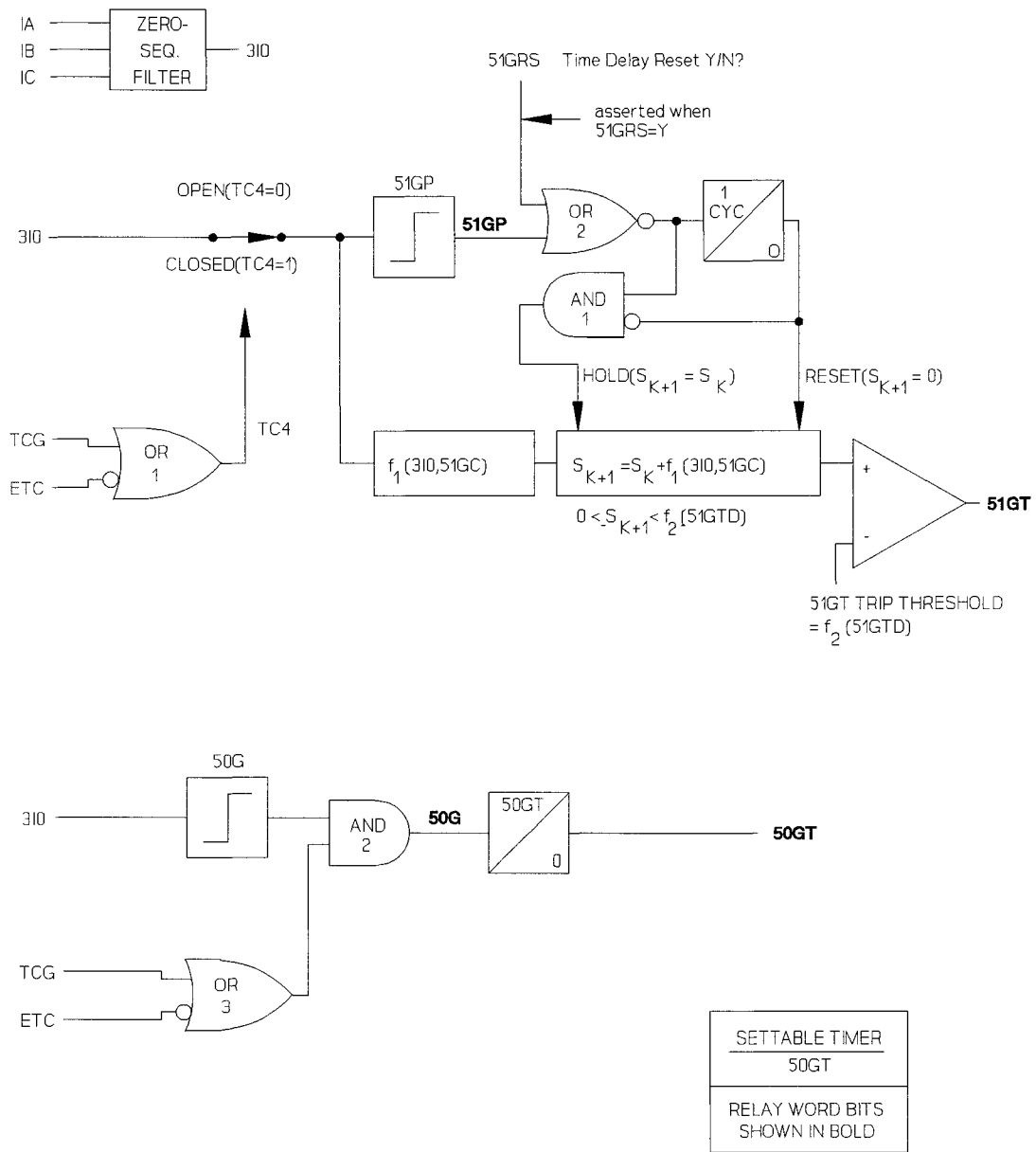
**Figure 2.16: Extremely Inverse Curves**



**Figure 2.17: Short-Time Inverse Curves**

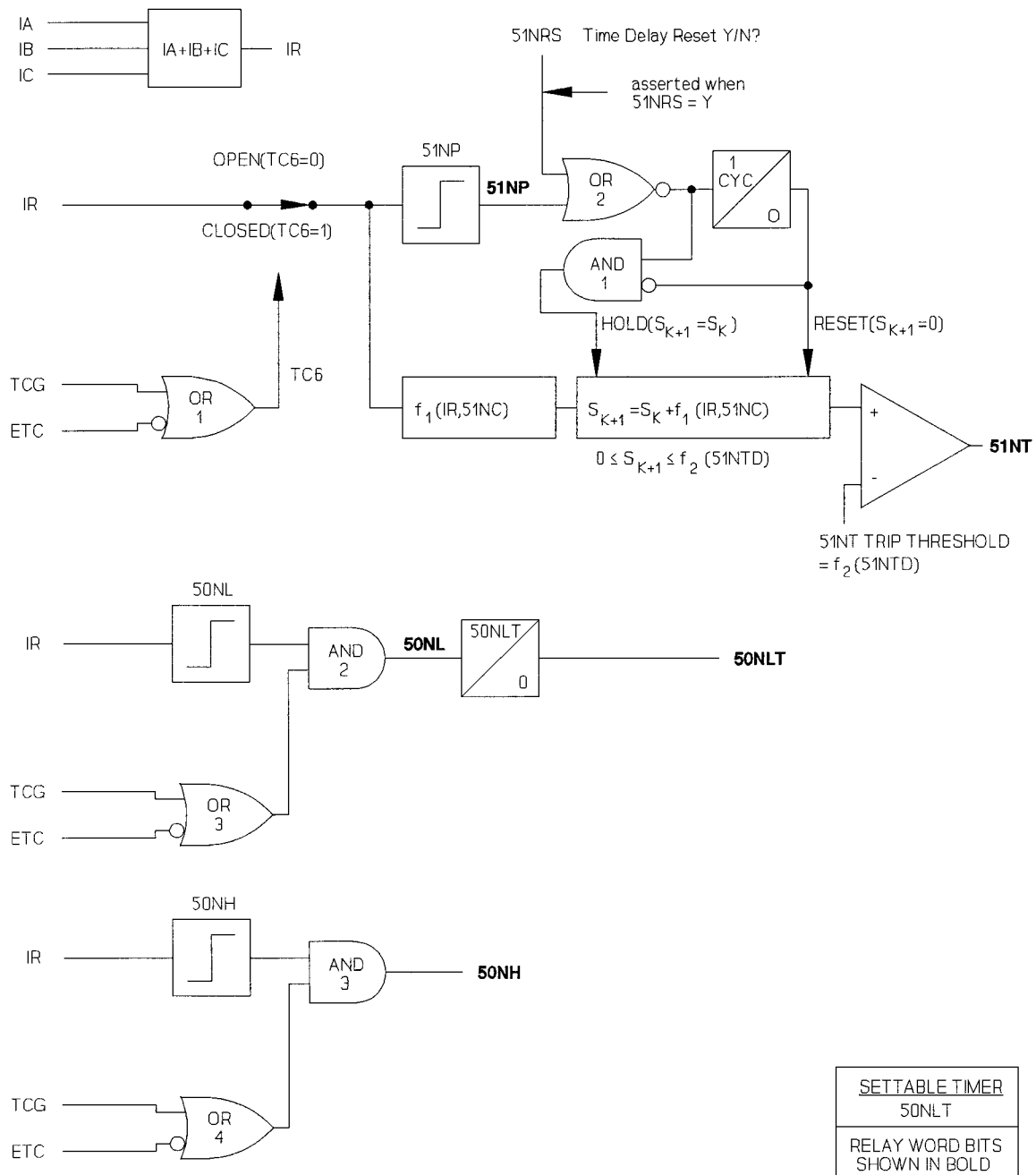


**Figure 2.18: SEL-251D-1 Phase Overcurrent Logic Diagrams**

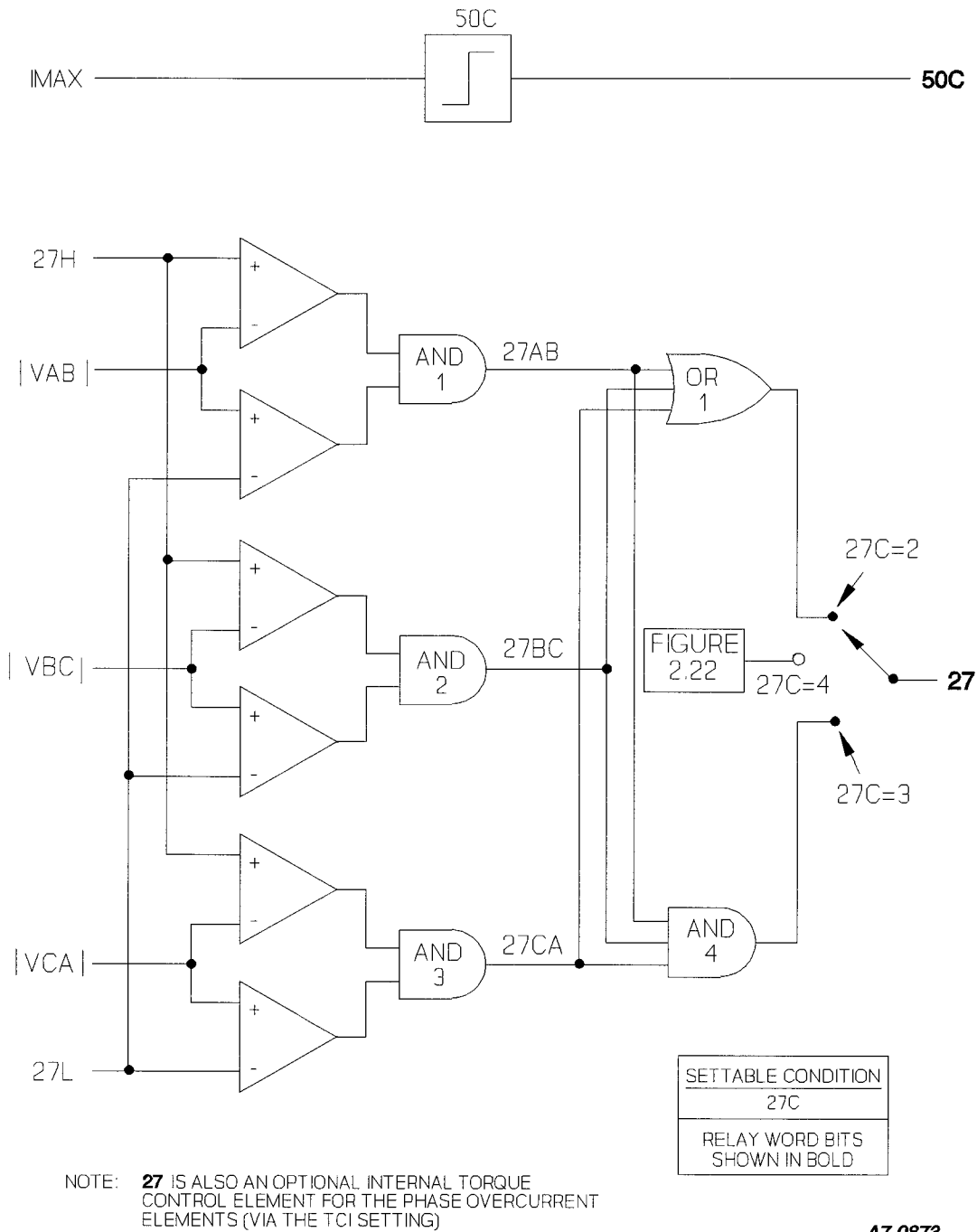


DWG. 1078-109

**Figure 2.19: SEL-251D-1 Ground/Residual Overcurrent Logic Diagrams**

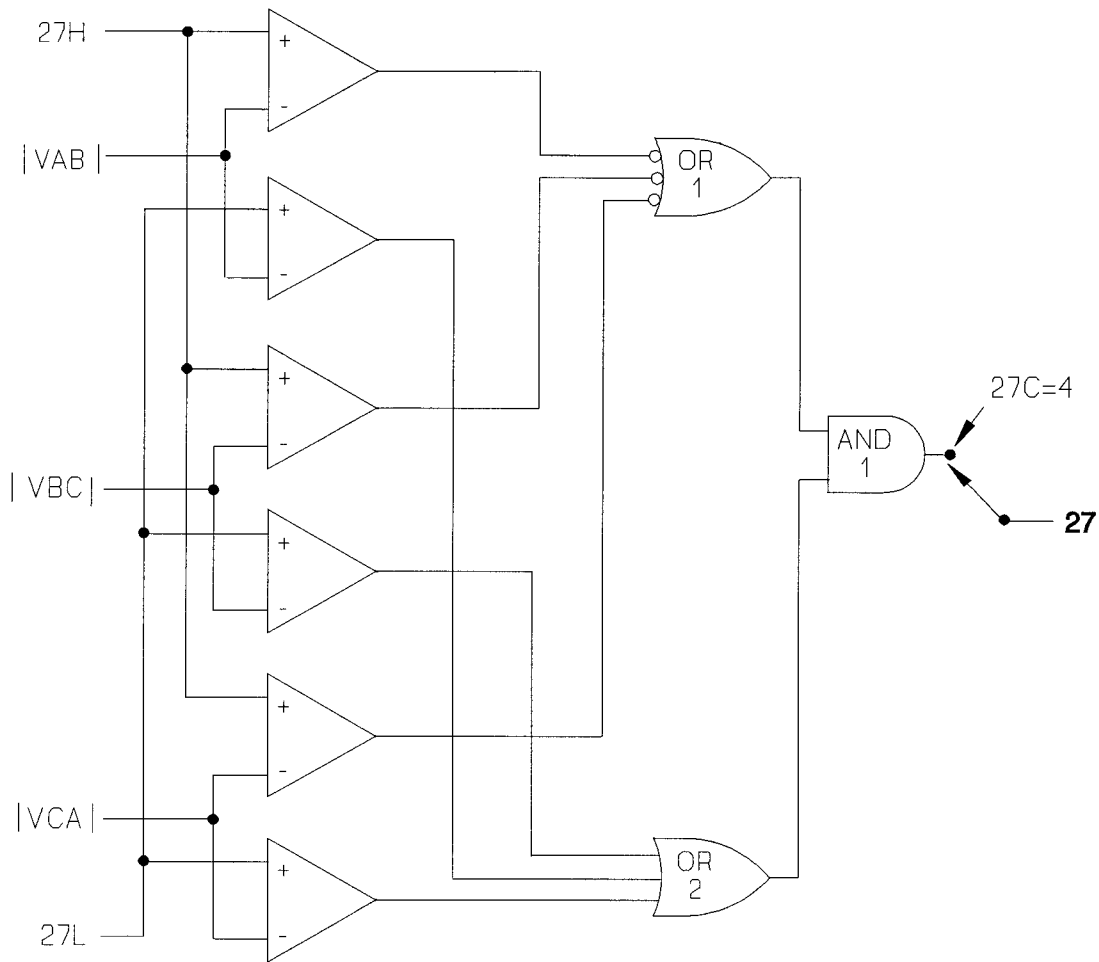


**Figure 2.20: SEL-251D-1 Ground/Residual Overcurrent Logic Diagrams**



**Figure 2.21: SEL-251D-1 Overcurrent and Undervoltage Elements**

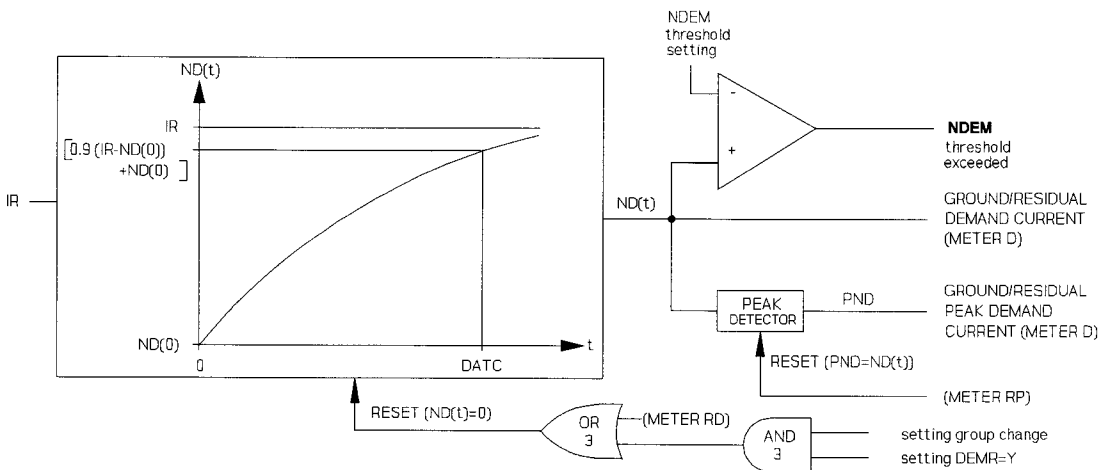
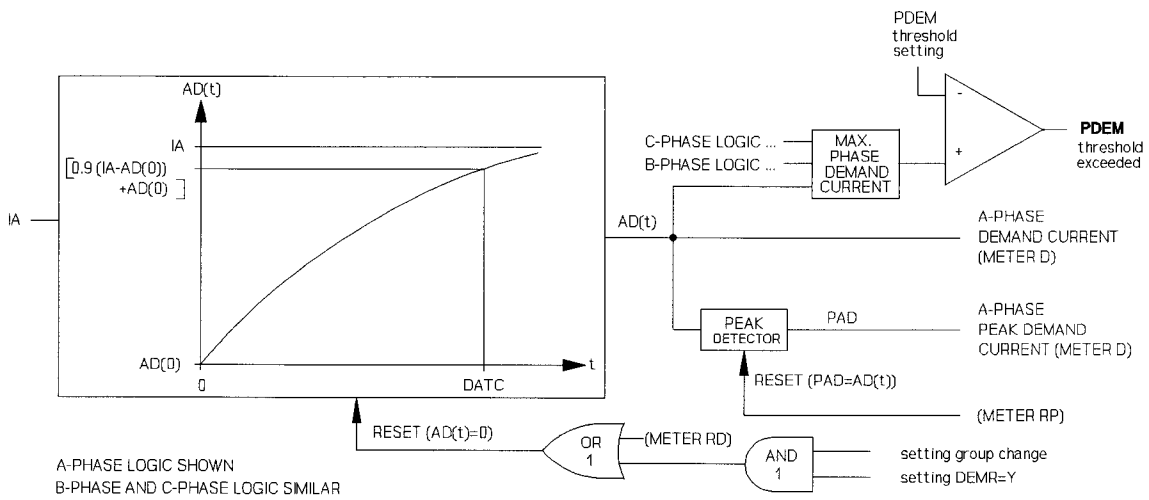




SETTABLE CONDITION
27C
RELAY WORD BITS SHOWN IN BOLD

A7-0873

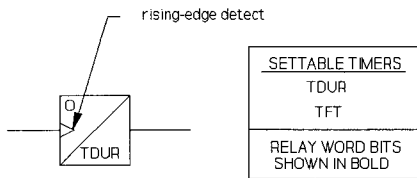
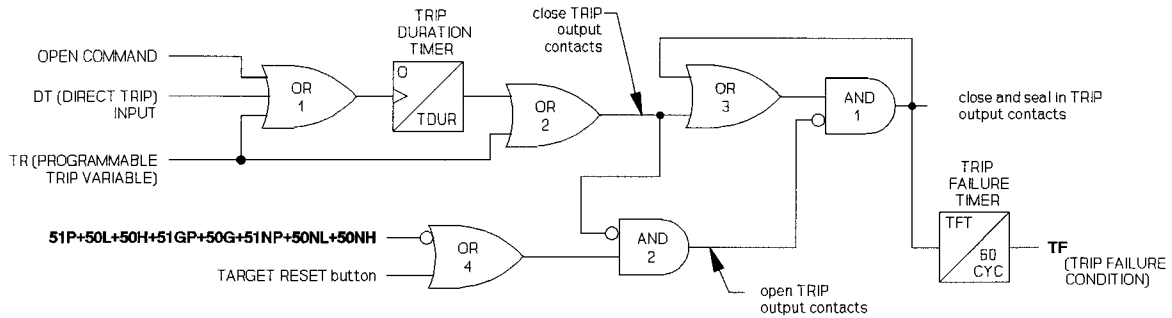
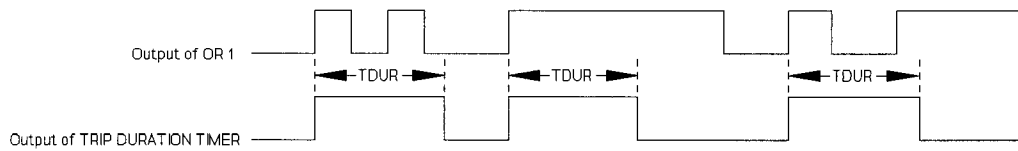
**Figure 2.22: SEL-251D-1 Transformer Blown-Fuse Detection Logic**



SETTABLE TIME CONSTANT
DATC
RELAY WORD BITS SHOWN IN BOLD

DWG. 1078-112

Figure 2.23: SEL-251D-1 Demand Ammeters



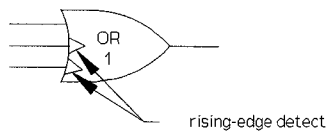
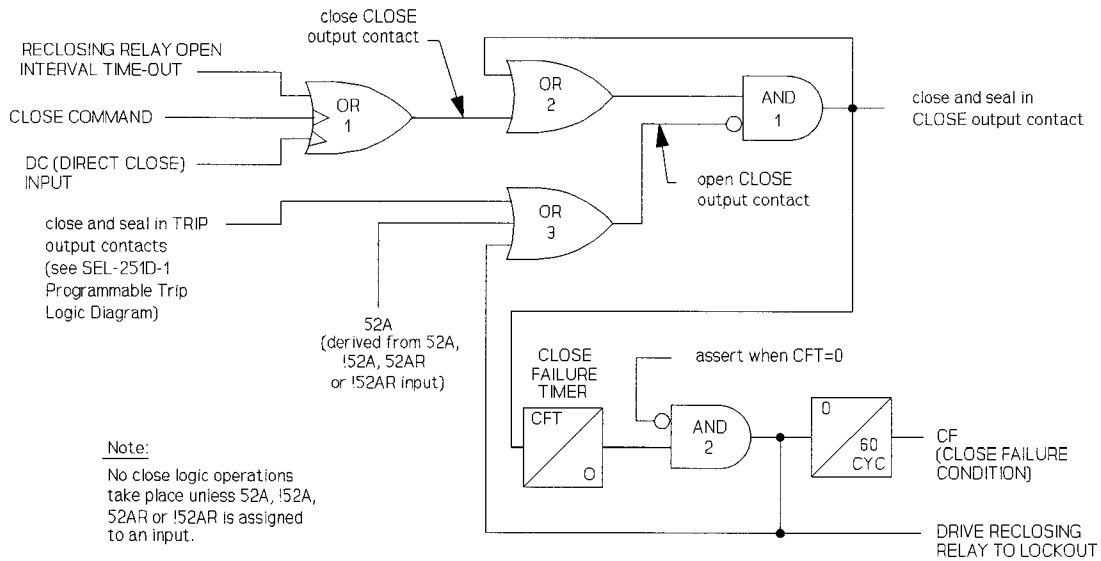
Note: Make the following settings:

**TDUR** > 0 to trip for OPEN command execution or DT (Direct Trip) input energization

**TFT** > **TDUR** to have a meaningful TF, trip failure condition

DWG. 1078-113

**Figure 2.24: SEL-251D-1 Programmable Trip Logic Diagram**



<b>SETTABLE TIMER</b>
<b>CFT</b>
<b>RELAY WORD BITS SHOWN IN BOLD</b>

When CFT = 0, the Close Failure Timer is effectively inoperative

DWG. 1096-106

Figure 2.25: SEL-251D-1 Close Logic Diagram

# COMMUNICATIONS TABLE OF CONTENTS

---

Introduction .....	3-1
Serial Port Connections and Configurations .....	3-1
Communications Protocol .....	3-3
Command Characteristics .....	3-5
Command Descriptions .....	3-7
SEL-251D-1 Relay Command Summary .....	3-35

## TABLES

Table 3.1: SEL-251D-1 Relay Serial Port Connector Pin Assignments .....	3-3
Table 3.2: Target LED Assignments .....	3-19

## FIGURES

Figure 3.1: 9-Pin Connector Pin Number Convention .....	3-2
---	-----



# COMMUNICATIONS

---

## INTRODUCTION

The relay is set and operated via serial communications interfaces connected to a computer terminal and/or modem or the SEL-PRTU. Communications serves these purposes:

1. The relay responds to commands spanning all functions, e.g., setting, metering, and control operations.
2. The relay generates an event record for assertions of the TRIP output, for an event triggering command, or for pickup of any relay element that triggers an event record.
3. The relay transmits messages in response to changes in system status, e.g., self-test warning.

It is impossible to disable any relaying or control functions via communications, unless a user enters erroneous or improper settings or logic with the SET or GROUP commands.

**Note:** In this manual, commands to type appear in bold/upper case: **OTTER**. Keys to press appear in bold/upper case/brackets: **<ENTER>**.

Relay output appears boxed and in the following format:

```
Example 21.6 kV distribution feeder    Date: 4/01/93  Time: 01:01:01
```

## SERIAL PORT CONNECTIONS AND CONFIGURATIONS

Port 1 and Port 2 are EIA RS-232-C serial data interfaces.

Port 1 is located on the rear panel and is generally used for remote communications via a modem or the SEL-PRTU.

Port 2 has connectors on both the front and rear panels, designated Port 2F and Port 2R, respectively. Port 2F has priority over Port 2R. These ports are generally used for local communications. Port 2R is typically connected to a printer, SEL-RD, or SEL-DTA. Port 2F is typically used for temporary communications via a portable terminal.

When a device is plugged into Port 2F, the relay automatically begins addressing Port 2F and discontinues communication with Port 2R. When a device unplugged from Port 2F, the relay automatically resumes communication with the device connected to Port 2R.

The baud rate of each port is set by jumpers near the front of the main board. You can access these jumpers by removing either the top cover or front panel. Available baud rates are 300, 600, 1200, 2400, 4800, or 9600.

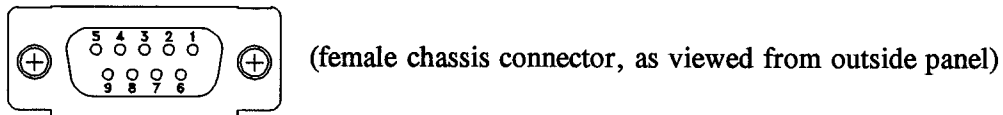
**Caution:** Do not select two baud rates for the same port as this can damage the relay baud rate generator. The relay is shipped with Port 1 set to 300 baud and Port 2F/2R set to 2400 baud.

The serial data format is:

Eight data bits  
Two stop bits (-E2 model) or one stop bit (-E1 model)  
No parity

This format may not be changed.

Figure 3.1 shows the pin number convention for the EIA RS-232-C data ports.



**Figure 3.1: 9-Pin Connector Pin Number Convention**



Table 3.1 lists port pin assignments and signal definitions.

<b>Table 3.1: SEL-251D-1 Relay Serial Port Connector Pin Assignments</b>			
<u>Pin</u>	<u>Port 1, Port 2R</u>	<u>Port 2F</u>	<u>Description</u>
1	+5 Vdc	N/C	+5 Vdc available if JMP12 installed
2	RXD	RXD	Receive data input.
3	TXD	TXD	Transmit data output.
4	+12 Vdc	N/C	+12 Vdc available if JMP13 installed
5	GND	GND	
6	-12 Vdc	N/C	-12 Vdc available if JMP14 installed
7	RTS	RTS	The relay asserts this line under normal conditions. When its received-data buffer is full, the line is deasserted, and asserts again when the buffer has sufficient room to receive more data. Connected devices should monitor RTS (usually with their CTS input) and stop transmission whenever the line deasserts. If transmission continues, data may be lost.
8	CTS	CTS	The relay monitors CTS, and transmits characters only if CTS is asserted.
9	GND	GND	Ground for ground wires and shields

## COMMUNICATIONS PROTOCOL

Communications protocol consists of hardware and software features. Hardware protocol includes the control line functions described above. The following software protocol is designed for manual and automatic communications.

1. All commands received by the relay must be of the form:

<command> <CR>    or    <command> <CRLF>

Thus, a command transmitted to the relay should consist of the command followed by either a carriage return or a carriage return and line feed. You may truncate commands to the first three characters. Thus, **EVENT 1 <ENTER>** would become **EVE 1 <ENTER>**. Upper and lower case characters may be used without distinction, except in passwords.

**Note:** The ENTER key on most keyboards is configured to send the ASCII character 13 (^M) for a carriage return. This manual instructs you to press the ENTER key after commands, which should send the proper ASCII code to the relay.

2. The relay transmits all messages in the following format:

```
<STX> <MESSAGE LINE 1> <CRLF>
      <MESSAGE LINE 2> <CRLF>
      .
      .
      <LAST MESSAGE LINE> <CRLF> <PROMPT> <ETX>
```

Each message begins with the start-of-transmission character (ASCII 02) and ends with the end-of-transmission character (ASCII 03). Each line of the message ends with a carriage return and line feed.

3. The relay indicates the volume of data in its received data buffer through an XON/XOFF protocol.

The relay transmits XON (ASCII hex 11) and asserts the RTS output when the buffer drops below 25% full.

The relay transmits XOFF (ASCII hex 13) when the buffer is over 75% full. The relay deasserts the RTS output when the buffer is approximately 95% full. Automatic transmission sources should monitor for the XOFF character so they do not overwrite the buffer. Transmission should terminate at the end of the message in progress when XOFF is received and may resume when the relay sends XON.

4. You can use an XON/XOFF procedure to control the relay during data transmission. When the relay receives XOFF during transmission, it pauses until it receives an XON character. If there is no message in progress when the relay receives XOFF, it blocks transmission of any message presented to its buffer. Messages will be accepted after the relay receives XON.

The CAN character (ASCII hex 18) aborts a pending transmission. This is useful in terminating an unwanted transmission.

5. Control characters can be sent from most keyboards with the following keystrokes:

```
XON:   <CTRL>Q (hold down the Control key and press Q)
XOFF:  <CTRL>S (hold down the Control key and press S)
CAN:   <CTRL>X (hold down the Control key and press X)
```

6. The relay input buffer is limited to 128 characters. If the buffer is over 75% full, the relay will send an XOFF to the terminal to terminate transmission. This should be avoided, as the relay may never send an XON if there are no termination characters (carriage returns) within the buffered text.

## COMMAND CHARACTERISTICS

The relay responds to commands sent to either serial communications interface. A two-level password system provides security against unauthorized access.

When the power is first turned on, the relay is in Access Level 0 and honors only the ACCESS command. It responds "Invalid command" or "Invalid access level" to any other entry.

You may enter Access Level 1 with the ACCESS command and first password. The Level 1 password is factory-set to OTTER and may be changed with the PASSWORD command in Access Level 2. Most commands may be used in Access Level 1.

Critical commands such as SET operate only in Access Level 2. You may enter Access Level 2 with the 2ACCESS command and second password. The Level 2 password is factory-set to TAIL and may be changed with the PASSWORD command.

### Startup

Immediately after power is applied, the relay transmits the following message to the port(s) designated automatic:

```
Example 21.6 kV distribution feeder    Date: 4/1/93   Time: 01:01:01
SEL-251D-1
=
```

The ALARM relay should pull in.

The = represents the Access Level 0 prompt.

The relays are shipped with Port 2 designated automatic; you may use the SET command to change this designation (see SET command, AUTO setting). This allows you to select Port 1, Port 2, or both ports to transmit automatic responses from the relay.

To enter Level 1, type the following on a terminal connected to Port 2:

```
=ACCESS <ENTER>
```

The response is:

```
Password: ? @@@@@@
```

Enter the Level 1 password **OTTER** and press **<ENTER>**. The response is:

```
Example 21.6 kV distribution feeder    Date: 4/1/93    Time: 01:01:44
Level 1
=>
```

The Access Level 1 prompt is =>. Now you can execute any Level 1 command.

Use a similar procedure to enter Access Level 2:

Type **2ACCESS <ENTER>**. The relay pulses the **ALARM** relay contact closed for approximately one second in response to your access attempt. Enter the password **TAIL** when prompted. After you enter the second password, the relay opens access to Level 2, as indicated by the following message and Level 2 prompt (=>>):

```
=>2ACCESS <ENTER>
Password:  TAIL <ENTER>

Example 21.6 kV distribution feeder    Date: 4/1/93    Time: 01:03:32
Level 2
=>>
```

You can enter any command at this prompt.

### Command Format

Commands consist of three or more characters; only the first three characters of any command are required. You may use upper or lower case characters without distinction, except in passwords.

You must separate arguments from the command by spaces, commas, semicolons, colons, or slashes.

You can enter commands any time after the terminal displays an appropriate prompt.

In this manual, commands to type appear in bold/upper case: **OTTER**. Keys to press appear in bold/upper case/brackets: **<ENTER>**. Some commands have optional parameters; these appear after the command in bold/lower case.

## COMMAND DESCRIPTIONS

### Access Level 0 Command

#### ACCESS

ACCESS allows you to enter Access Level 1. The password is required unless you install jumper JMP103. The first password is set to OTTER at the factory; use the Level 2 command PASSWORD to change passwords.

The following display indicates successful access:

```
=ACCESS <ENTER>
Password:  OTTER <ENTER>

Example 21.6 kV distribution feeder    Date: 4/1/93   Time: 14:03:57
Level 1
=>
```

The => prompt indicates Access Level 1.

If you enter incorrect passwords during three consecutive attempts, the relay pulses the ALARM contact closed for one second. This feature can alert personnel to an unauthorized access attempt if the ALARM contact is connected to a monitoring system.

### Access Level 1 Commands

#### 2ACCESS

2ACCESS allows you to enter Access Level 2. The password is required unless you install jumper JMP103. The second password is set to TAIL at the factory; use the Level 2 command PASSWORD to change passwords.

The following display indicates successful access:

```
=>2ACCESS <ENTER>  
Password:  TAIL <ENTER>
```

```
Example 21.6 kV distribution feeder    Date: 4/1/93    Time: 14:12:01
```

```
Level 2  
=>>
```

You may use any command from the = > > prompt. The relay pulses the ALARM output contact closed for one second after any Level 2 access attempt (unless an alarm condition exists). If access is denied, the ALARM output contact pulses again.

### **BREAKER**

BREAKER displays running sums of circuit breaker trips for relay and external trips and interrupted current in each circuit breaker pole for relay and external trips.

Relay trips are determined by coinciding change in circuit breaker auxiliary contact input status (52A drops out or 52B asserts) and relay TRIP output contact assertion. Consideration should be given to the TDUR (trip duration) timer setting so TRIP output contact assertion always encompasses the status change of the circuit breaker auxiliary contact for a relay initiated trip. See the note concerning circuit breaker status input options in the SET G command section.

External trips are determined by coinciding change in circuit breaker auxiliary contact input status (52A drops out or 52B asserts) and the absence of relay TRIP output contact assertion.

For trips, the relay measures interrupted current in each pole one cycle after the rising edge of TRIP contact assertion.

For external trips, the relay measures interrupted current in each pole when the status of the circuit breaker auxiliary contact input changes (52A drops out or 52B asserts). Remember to consider the time delay between the change of circuit breaker auxiliary contact status and the opening of circuit breaker main contacts. If circuit breaker auxiliary contact operation lags too far behind circuit breaker main contact operation, current may already be interrupted when the circuit breaker auxiliary contact changes status. Thus, no interrupted current would be measured.

BREAKER also displays the date and time when circuit breaker trip counters and interrupted current sums were last reset (set to zero). Cumulative currents appear in kA (kiloamperes).

```
=>BREAKER <ENTER>

Example 21.6 kV distribution feeder   Date: 4/1/93   Time: 09:09:58

Rly Trips=15      From: 1/1/91   11:01:31
IA=42.65      IB=37.91      IC=34.20

Ext Trips=2      From: 1/1/91   11:01:31
IA=0.65      IB=0.67      IC=0.62

=>
```

If power to the relay is interrupted, the accumulated circuit breaker information is lost.

If the 52A, !52A, 52AR, or !52AR function is not assigned to an input, circuit breaker trips and interrupted currents cannot be accumulated.

**BREAKER R**

BREAKER R resets (sets to zero) the circuit breaker trip counters and interrupted current sums. The relay also stores reset date and time.

```
=>BREAKER R <ENTER>
Reset Trip Counters and Current Sums:
Are you sure (Y/N) ? Y <ENTER>

Example 21.6 kV distribution feeder   Date: 4/1/93   Time: 09:10:30

Rly Trips=0      From: 4/2/91   09:10:30
IA=0.00      IB=0.00      IC=0.00

Ext Trips=0      From: 4/2/91   09:10:30
IA=0.00      IB=0.00      IC=0.00

=>
```

**DATE mm/dd/yy**

DATE displays the date stored by the internal calendar/clock. To set the date, type **DATE mm/dd/yy <ENTER>**.

To set the date to April 1, 1993, enter:

```
=>DATE 4/1/93 <ENTER>
4/1/93
=>
```

The relay sets the date, pulses the ALARM relay closed as it stores the year in EEPROM (if the year input differs from the year stored), and displays the new date.

### EVENT n

EVENT displays an event report. Type **EVENT n <ENTER>** to display an event report for the nth event. The parameter n ranges from 1 for the newest event through 12 for the oldest event stored in relay memory. If n is not specified, the default value is 1 and the relay displays the newest event report.

You can control transmissions from the relay with the following keystrokes:

- **<CTRL>S**      Pause transmission
- **<CTRL>Q**      Continue transmission
- **<CTRL>X**      Terminate transmission

The following incidents clear the event buffers:

- Control power interruption
- Changing any relay setting via the SET commands
- Changing any relay setting group via the COPY command

Switching setting groups does not clear the buffers.

All event data are lost when event buffers are cleared. If an event buffer is empty when you request an event, the relay returns an error message:

```
=>EVENT 12 <ENTER>
Invalid event
=>
```

Section 4: **EVENT REPORTING** explains the generation and analysis of event reports.



## HISTORY

HISTORY displays the date, time, event type, reclosing relay shot, maximum phase current, enabled setting group, and fault type targets for each of the last twelve events. If the event is a fault, the fault location also appears. The full eleven-cycle event reports also include this information (EVENT n to display).

```
=>HISTORY <ENTER>
Example 21.6 kV distribution feeder      Date: 4/1/93      Time: 09:11:27
#  DATE      TIME      EVENT  LOCAT  SHOT  CURR  GROUP  TARGETS
1  1/2/93     01:36:59.070  AG T   2.43   0    2798   2    INSTAG
2  12/17/92   08:07:40.129  CG T   3.52   1    2361   3    INSTCG
3  12/17/92   08:07:35.133  CG T   3.51   0    2364   3    INSTCG
4  12/15/92   01:07:35.862  TRIG          0     345    1
5
6
7
8
9
10
11
12
=>
```

Note that only four events have occurred since the relay was set or powered on.

The time is saved to the nearest quarter-cycle (4.17 ms) and referenced to the 16th row of data in the report. All reports trigger at row 16. If a long fault triggers two event reports, you can still determine its duration. Simply calculate the time difference between the first report generated at fault inception and the second report generated at the TRIP.

The EVENT column provides an abbreviated indication of the event type.

The following incidents trigger an event report:

- TRIP output contact assertion
- ER (Event Report trigger) programmable variable assertion
- Input assigned to ET (External Trigger) function assertion
- TRIGGER command execution

If an event report is triggered and at least one of the overcurrent elements pickup in Relay Word row R1, the fault locator operates. If the fault locator operates successfully, the EVENT column shows phase involvement.

The relay determines phase involvement independently from relay elements and labels it with a selection from the following list. Phase involvement is determined solely using uncompensated and load compensated current magnitudes. The relay measures these magnitudes at the midpoint of the first continuous relay element pickup sequence in the event report (for algorithmic details, see the Fault Locator description in Section 2: SPECIFICATIONS).

AG : For A $\phi$  to ground faults  
BG : For B $\phi$  to ground faults  
CG : For C $\phi$  to ground faults  
AB : For A-B two-phase faults  
BC : For B-C two-phase faults  
CA : For C-A two-phase faults  
ABG : For A-B two-phase to ground faults  
BCG : For B-C two-phase to ground faults  
CAG : For C-A two-phase to ground faults  
ABC : For three-phase faults

If the TRIP output contacts are asserted during the event report, a "T" follows the EVENT designation. This helps to determine clearing times for faults which persist beyond the end of the first event report. For example, if the relay trips for a BG fault after completing the initial report, the second report shows "BG T" for EVENT.

If an event report is triggered but the fault locator does not operate, the event report triggering condition appears in the EVENT column. These conditions are:

TR : programmable TRipping variable  
DT : Direct Trip input  
OPEN : OPEN command  
ER : programmable Event Report trigger variable  
ET : External Trigger input  
TRIG : TRIGGER command

If two or more event report triggering conditions happen to coincide when the fault locator does not operate, the relay uses the previous hierarchy to display the event report triggering condition in the EVENT column.

The LOCAT column shows the equivalent distance to a fault. Event report distances appear without units, which allows you to use any unit of measure for line parameter settings. The relay calculates distance using the Takagi algorithm or a reactance measurement, depending on whether pre-fault data are available in the event report. For some long duration boundary faults, the fault location may not be possible for every report generated when relay operation is sporadic. The DIST column may contain "999999" in such cases. While this behavior can be contrived under test conditions, it is extremely rare in actual practice.

The SHOT column lists the reclosing relay shot when the event report was initiated.

The CURR column shows maximum phase current magnitude measured at the middle of the fault in primary amperes. This information can help you identify the row pair used by the relay for fault location calculations. If the fault locator is not run for an event report, the event report shows maximum phase current when the event report was triggered.

The GROUP column has the number of the setting group active at the time the report was triggered.

The TARGETS column lists the FAULT TYPE front panel targets illuminated at event report initiation.

If the event buffers are cleared, the event summaries listed by the HISTORY command are lost (see EVENT in this section).

### IRIG

IRIG directs the relay to read the demodulated IRIG-B time code input (J201) on the rear panel.

If the relay reads the time code successfully, it updates the internal clock/calendar time and date to the time code reading, and the relay transmits a message with relay ID string, date, and time.

```
=>IRIG <ENTER>
```

```
Example 21.6 kV distribution feeder    Date: 4/1/93    Time: 01:45:40
```

```
=>
```

If no IRIG-B signal is present or the code cannot be read successfully, the relay sends the error message "IRIGB DATA ERROR."

**Note:** Normally, it is not necessary to synchronize using this command because the relay automatically synchronizes every few minutes. The command is provided to speed testing.

### METER n

METER displays **present** values of the following:

IA : A $\phi$  current (primary amps)  
B : B $\phi$  current (primary amps)  
C : C $\phi$  current (primary amps)  
R : Ground/residual current (primary amps)

P : Three-phase real power (MW)  
Q : Three-phase reactive power (MVAR)

VAB : AB phase-to-phase voltage (primary volts)  
VBC : BC phase-to-phase voltage (primary volts)  
VCA : CA phase-to-phase voltage (primary volts)

```
=>METER <ENTER>
```

```
Example 21.6 kV distribution feeder    Date: 4/1/93    Time: 09:12:49
```

```
MET IA=356    B=364    C=361    R=6  
    P=12.910    Q=1.130
```

```
VAB=20827    VBC=20839    VCA=20836
```

```
=>
```

P is positive when three-phase real power flows out from the bus and into the line. If P is negative, three-phase real power flows in the opposite direction. Q is positive when three-phase reactive power flows from the bus and into the line (net load on the line has a lagging power factor). If Q is negative, three-phase reactive power flows in the opposite direction (net load on the line has a leading power factor). If Q = 0, no net reactive power is flowing past the relay (net load on the line has a unity power factor).

The optional parameter n selects the number of times the relay displays meter data. To display a series of eight meter readings, type **METER 8 <ENTER>**.

### METER D

METER D displays **demand** and **peak demand** values of the following:

- IA : A $\phi$  current (primary amps)
- B : B $\phi$  current (primary amps)
- C : C $\phi$  current (primary amps)
- R : Ground/residual current (primary amps)
  
- P : Three-phase real power (MW)
- Q : Three-phase reactive power (MVAR)

The demand ammeter time constant setting (DATC) is also used in determining I, P, and Q demand values.

```

=>METER D <ENTER>

Example 21.6 kV distribution feeder      Date: 4/1/93   Time: 09:13:33

DEM IA=347      B=349      C=349      R=4
  P=12.897      Q=0.997

PK  IA=412      B=410      C=414      R=15
  P=14.701      Q=1.280

=>

```

If control power to the relay is interrupted, the demand and peak demand values reset to zero.

**METER RD**

METER RD resets **demand** values to zero.

```

=>METER RD <ENTER>
Reset Demand Meter: Are you sure (Y/N) ? Y <ENTER>

Example 21.6 kV distribution feeder      Date: 4/1/93   Time: 09:14:15

DEM IA=0        B=0        C=0        R=0
  P=0.000        Q=0.000

PK  IA=412      B=410      C=414      R=15
  P=14.701      Q=1.280

=>

```

The demand values automatically reset if an active setting group change is made with global setting DEMR=Y (see SET G p in this section).

**METER RP**

METER RP resets **peak demand** values to their respective demand values.

```
=>METER RP <ENTER>
```

```
Reset Peak Demand: Are you sure (Y/N) ? Y <ENTER>
```

```
Example 21.6 kV distribution feeder    Date: 4/1/93    Time: 10:31:26
```

```
DEM IA=341    B=345    C=348    R=5  
    P=12.875    Q=0.757
```

```
PK IA=341    B=345    C=348    R=5  
    P=12.875    Q=0.757
```

```
=>
```

### QUIT

QUIT returns control to Access Level 0 from Level 1 or 2 and resets targets to the Relay Targets (TAR 0). The command displays the relay I.D., date, and time of QUIT command execution.

Use this command when you finish communicating with the relay to prevent unauthorized access. Control returns to Access Level 0 automatically after a settable interval of no activity (see the TIME1 and TIME2 settings of the SET command).

```
=>QUIT <ENTER>
```

```
Example 21.6 kV distribution feeder    Date: 4/1/93    Time: 01:45:40
```

```
=
```

### SHOWSET n

SHOWSET n displays the relay and logic settings for setting group n (n = 1, 2, 3, 4, 5, or 6). You cannot enter or modify settings with this command. The SET command description provides complete information about changing settings and logic. To display the active setting group, execute SHOWSET without the parameter n.

The display also includes the global settings (settings common to all groups).

The SHOWSET output pauses twice, as shown in the following example. Press <ENTER> to continue viewing the next section of settings.

=>SHOWSET 1 <ENTER>

Settings for group 1

Example 21.6 kV distribution feeder

CTR =120.00 PTR =180.00  
R1 =0.58 X1 =1.50 RO =1.44 X0 =4.56  
ROS =0.05 XOS =0.53 LL =2.42  
DATC =15 PDEM =12.00 NDEM =12.00  
790I1=30 790I2=0 790I3=0 790I4=0  
79RST=1800 M79SH=10000  
50C =99.99 27L =0.00 27H =0.00 27C =2 TCI =0  
50G =99.99 50GT =0  
51GP =12.00 51GTD=15.00 51GC =4 51GRS=N  
50NL =2.01 50NLT=0 50NH =39.99  
51NP =1.50 51NTD=3.00 51NC =4 51NRS=N  
50L =99.99 50LT =0 50H =39.99  
51P =6.00 51TD =5.00 51C =4 51RS =N  
52APU=0 52ADO=0 TSPU =0 TSDO =0  
TKPU =1 TKDO =0 TZPU =0 TZDO =0

PRESS RETURN ? <ENTER>

SELogic Equations

S(123) =  
A(12) =50NL  
B(12) =50NH+51NT  
C(12) =  
D(12) =  
E(34) =  
F(34) =  
G(34) =  
H(34) =IN6  
J(1234) =79SH  
K(1234) =IN5  
L(1234) =  
A1(1234)=  
A2(1234)=

PRESS RETURN ? <ENTER>

V(56) =A\*H\*J  
W(56) =B\*H  
X(56) =J\*K  
Y(56) =  
Z(56) =  
A3(1346)=  
A4(2346)=  
TR(1246)=50H+51T+V+W+X  
RC(1246)=  
ER(1246)=  
SEQ(1) =  
ETC(1) =51P  
ITC(1) =

Global settings

DEMUR =Y CFT =0 TDUR =4 TFT =0 TGR =180  
ITT =5 TIME1=15 TIME2=0 AUTO =2 RINGS=3  
IN1 = IN2 =TCP IN3 =!RE IN4 =52A  
IN5 = IN6 =

=>

## STATUS

STATUS allows inspection of self-test status. The relay automatically executes the STATUS command whenever a self-test enters a warning or failure state. If this occurs, the relay transmits a STATUS report from the port(s) designated automatic (see SET command, AUTO setting).

The STATUS report format appears below.

```
=>STATUS <ENTER>

Example 21.6 kV distribution feeder    Date: 4/1/93    Time: 01:08:44

SELF TESTS

W=Warn F=Fail
   IR   IA   IB   IC   VAB  VBC  VCA
OS    0    0    0    0    2    0    2
PS    5.11    15.15    -14.91
RAM   ROM   A/D   MOF   SET
OK    OK    OK    OK    OK

=>
```

The OS row indicates measured dc offset voltages in millivolts for the seven analog channels. An out-of-tolerance offset is indicated by a W (warning) or F (failure) following the displayed offset value.

The PS row indicates power supply voltages in volts for the three power supply outputs.

If a RAM or ROM test fails, the IC socket code of the defective part replaces OK.

The A/D self-test checks analog-to-digital conversion time.

The MOF test checks dc offset in the MUX-PGA-A/D circuit.

The SET self-test calculates a checksum of the settings stored in nonvolatile memory and compares it to the checksum calculated when the settings were last changed.

Section 2: SPECIFICATIONS provides full definitions of the self-tests, warning and failure limits, and warning and failure results.

### **TARGET n k**

TARGET selects the information to be displayed on the target LEDs and to be communicated by this command.

When relay power is first turned on, the LED display indicates the functions marked on the front panel.

Using the TARGET command, you may select any one of the following nine sets of data to display on the LEDs.



**Table 3.2: Target LED Assignments**

LED:	1	2	3	4	5	6	7	8	
n									
0	INST	A	B	C	G	RS	CY	LO	Front Panel Targets
1	51P	50L	50H	51GP	50G	51NP	50NL	50NH	Relay Word row R1
2	51T	50LT	50C	51GT	50GT	51NT	50NLT	27	Relay Word row R2
3	79RS	79CY	79LO	79SH	52AT	52BT	IN6	IN5	Relay Word row R3
4	PDEM	CLOS	NDEM	TF	CF	TCMA	ST	TRIP	Relay Word row R4
5	A	B	C	D	E	F	G	H	Relay Word row R5
6	J	KT	!L	V	W	X	Y	ZT	Relay Word row R6
7			IN6	IN5	IN4	IN3	IN2	IN1	Inputs
8		TRIP	CLOSE	A1	A2	A3	A4	ALRM	Output Contacts

These selections are useful in testing, checking contact states, and reading targets remotely. "1" indicates an asserted element; "0" indicates a deasserted element.

The optional command parameter k selects the number of times the relay displays target data for parameter n. The example below shows a series of ten target readings for Relay Word row R3. Target headings repeat every eight rows. You cannot use parameter k without parameter n.

```

=>TARGET 3 10 <ENTER>

79RS 79CY 79LO 79SH 52AT 52BT IN6 IN5
1 0 0 1 1 0 0 0
1 0 0 1 1 0 0 0
1 0 0 1 1 0 0 0
1 0 0 1 1 0 0 0
1 0 0 1 1 0 0 0
1 0 0 1 1 0 0 0
1 0 0 1 1 0 0 0
1 0 0 1 1 0 0 0
1 0 0 1 1 0 0 0

79RS 79CY 79LO 79SH 52AT 52BT IN6 IN5
1 0 0 1 1 0 0 0
1 0 0 1 1 0 0 0

=>
    
```

When you are finished, type **TAR 0 <ENTER>** to return to the functions marked on the front panel so field personnel do not misinterpret displayed data.

When a serial port times out (see **TIME1**, **TIME2** settings) and an automatic message is sent to that port, the relay automatically clears the targets and displays the **TAR 0** data.

Press the front panel **TARGET RESET** button to clear the **TAR 0** data and illuminate all target LEDs for a one second lamp test.

If you place the relay in service with a target level other than Level 0, it automatically returns to target Level 0 when an automatic message transmits to a timed out port. While this feature prevents confusion among station operators and readers, it can be inconvenient if the relay tester requires targets to remain on another level. Targets remain in the specified level if you assign the **AUTO** setting to a port with zero timeout or set both **TIME1** and **TIME2** to zero. This halts automatic message transmission to a port which may be timed out.

### **TARGET R**

You can reset front panel targets to **TAR 0** and clear them remotely or locally with the **TARGET R** command. Type **TARGET R <ENTER>** to reset and clear the targets as shown in the following example.

```
=>TARGET R <ENTER>
Targets reset

INST A   B   C   G   RS   CY   LO
0   0   0   0   0   1   0   0

=>
```

### **TIME hh:mm:ss**

**TIME** displays the internal clock. To set the clock, type **TIME** and the desired setting, then press **<ENTER>**. Separate the hours, minutes, and seconds with colons, semicolons, spaces, commas, or slashes. To set the clock to 23:30:00, enter:

```
=>TIME 23:30:00 <ENTER>
23:30:00
=>
```

A quartz crystal oscillator provides the time base for the internal clock. You can set the clock automatically through the relay time code input with a source of demodulated IRIG-B time code.

## TRIGGER

TRIGGER generates an event record. After command entry, the relay responds "Triggered" and displays a record summary.

```
=>TRIGGER <ENTER>
Triggered

=>

Example 21.6 kV distribution feeder   Date: 4/1/93   Time: 10:45:20.000

Event   : TRIG   Location:           Shot:   0   Targets:
Currents (A pri), ABCG:           347   354   355   6

=>
```

Use TRIGGER to inspect input voltages. For example, when the relay is first installed, execute the TRIGGER command, draw the phasors (Section 4: EVENT REPORTING explains how to do this), and check for the proper polarity and phase sequence of the inputs.

### Access Level 2 Commands

While all commands are available from Access Level 2, the commands below are available only from Access Level 2. Remember, the relay pulses the ALARM contacts closed for one second after any Level 2 access attempt.

## CLOSE

The CLOSE command asserts the CLOSE output relay when jumper JMP104 is installed on the main board, the circuit breaker status input (52A, !52A, 52AR, or !52AR) indicates an open circuit breaker, and the TRIP outputs are not asserted. The CLOSE output relay then remains closed until the circuit breaker status input indicates that the circuit breaker has closed or until the close failure timer (CFT) expires.

To close the circuit breaker with this command, type **CLOSE <ENTER>**. The relay responds with the message: "Close BREAKER (Y/N) ?" **Y <ENTER>** yields a second prompting string: "Are you sure (Y/N) ?" Type **Y <ENTER>** to assert the CLOSE output relay if the TRIP output and 52A input are not asserted. The relay transmits the message "Breaker CLOSED" when the breaker closes or if it is already closed (as determined by 52A input state). Typing **N <ENTER>** after either of the above messages aborts the closing operation with the message "Aborted."

```
=>>CLOSE <ENTER>
Close BREAKER (Y/N) ? Y <ENTER>
Are you sure (Y/N) ? Y <ENTER>
Breaker CLOSED
=>>
```

After CLOSE command execution, if the response is "Breaker OPEN" instead of "Breaker CLOSED," the circuit breaker status input (52A, !52A, 52AR, or !52AR) did not indicate circuit breaker closure.

### COPY m n

COPY m n copies settings and logic from setting group m to group n (m and n equal any combination of 1, 2, 3, 4, 5, or 6).

Usually, there are only a few setting or logic differences between groups. If you enter one setting group with the SET command, you can copy it to other groups with the COPY command. Use SET to modify copied setting groups.

COPY command execution clears the event report buffer. If n is the active setting group, the ALARM output contact closes momentarily.

```
=>>COPY 4 6
Are you sure (Y/N) ? Y <ENTER>

Please wait...
Settings copied

=>
```

### GROUP n

GROUP n designates the Group Variable. This variable specifies which setting group to use when no Setting Group Selection inputs are assigned or all assigned inputs are deasserted (n = 1, 2, 3, 4, 5, or 6). You can execute this command at any time, but the setting group changes only when no Setting Group Selection inputs are assigned or all assigned inputs are deasserted. Otherwise, the current setting group remains active; the Group Variable becomes the Active Group only when no Setting Group Selection inputs are assigned or all assigned inputs are deasserted.

GROUP n command execution does not clear the event report buffer. However, any time the active setting group is changed, the relay pulses ALARM output contacts.

If global setting DEMR=Y and the active setting group is changed, the demand values are reset (see SET G p in this section).

```
=>>GROUP 3 <ENTER>
Change Group Variable:
Are you sure (Y/N) ? Y <ENTER>

=>>
Active Group = 1
Group Variable = 3

=>
```

The above response to **GROUP 3** command execution indicates that only Setting Group Selection input SS1 is energized (see Table 2.3) because the active group did not change to Group 3, but remained Group 1.

If you do not designate a setting group, the relay displays present group information:

```
=>>GROUP <ENTER>

Active Group = 1
Group Variable = 3

=>
```

### OPEN

The OPEN command closes the TRIP output contacts when jumper JMP104 is installed on the main board. TRIP output contacts remain closed for at least the duration of TDUR (you must enter a TDUR setting) starting with the rising edge of the trip output. The TRIP outputs drop out only if none of the overcurrent element pickups in Relay Word row R1 are picked up or if you push the TARGET RESET button on the front panel.

To open the power circuit breaker by command, type **OPEN <ENTER>**. The prompt "Open BREAKER (Y/N) ?" is transmitted. Answering **Y <ENTER>** yields a second prompt: "Are you sure (Y/N) ?" Answering **Y <ENTER>** again closes the TRIP output relay as described above.

```

=>>OPEN <ENTER>
Open BREAKER (Y/N) ? Y<ENTER>
Are you sure (Y/N) ? Y<ENTER>
Breaker OPEN
=>>

Example 21.6 kV distribution feeder   Date: 4/1/93   Time: 10:45:20.000

Event   : TRIG   Location:           Shot:   0   Targets:
Currents (A pri), ABCG:           347   354   355   5

=>>

```

After OPEN command execution, if the relay responds "Breaker CLOSED" instead of "Breaker OPEN," the circuit breaker status input (52A, !52A, 52AR, or !52AR) did not indicate circuit breaker opening.

### PASSWORD (1 or 2) password

PASSWORD allows you to inspect or change existing passwords. To inspect passwords, type **PASSWORD <ENTER>** as the following example shows:

```

=>>PASSWORD <ENTER>
1: OTTER
2: TAIL
=>>

```

To change the password for Access Level 1 to BIKE enter the following:

```

=>>PASSWORD 1 BIKE <ENTER>
Set
=>>

```

The relay sets the password, pulses the ALARM relay closed, and transmits the response "Set."

After entering new passwords, type **PASSWORD <ENTER>** to inspect them. Make sure they are what you intended and record the new passwords.

Passwords can be any length up to six numbers, letters, or any other printable characters except delimiters (space, comma, semicolon, colon, slash). Upper and lower case letters are treated as different characters. Examples of valid, distinct passwords include:

OTTER otter Ot3456 +TAIL+ !@#%^ 123456 12345. 12345

If the passwords are lost or you wish to operate the relay without password protection, install JMP103 on the main board. With no password protection, you may gain access without knowing the passwords and view or change current passwords and settings.

### SET n p

SET n allows entry of relay settings and logic for setting group n. At the setting procedure prompts (?), enter new data or press <ENTER> to retain existing settings. You can jump to a specific setting by entering the setting name as parameter p. If p is a SELOGIC™ Control Equations element, you do not need to include the parenthetical [e.g., just K, not K(1234)]. If you do not specify a setting, the procedure initiates at the first setting, Relay ID.

The relay prompts you for each group setting and checks the new setting against established limits. If a setting falls within its setting range, the relay prompts you for the next group setting. If a setting is outside its established limits, an "Out of range" or "Invalid" error message results. You have another chance to enter the setting. If you want to retain the old setting, press <ENTER> and proceed to the next group setting.

The logic variable expressions should contain the name of each Relay Word bit (e.g., 51P) and the correct delimiter "+" for OR logic, "\*" for AND logic, and "," for the ETC(1) and ITC(1) torque control logic variables. Enter the logic expression with no spaces between the Relay Word bits and the delimiters. Some examples:

A(12) = 51P+51NP

OR logic variable A takes bits from Relay Word rows 1 and 2 and uses the + delimiter.

V(56) = A\*F\*KT

AND logic variable V takes bits from Relay Word rows 5 and 6 and uses the \* delimiter.

ITC(1) = 50L,50H

The 50L and 50H phase overcurrent elements from Relay Word row 1 are selected for internal torque control. The respective time delayed elements they control (50LT and 50HT) are also internally torque controlled through this setting.

Note that AND logic variables V, W, X, Y, and ZT cannot select other AND variables from Relay Word rows 5 and 6. They can only select the OR logic variables A, B, C, D, E, F, H, J, KT, and !L from Relay Word rows 5 and 6. This prevents recursive logic such as:

V(56) = V\*W

(this setting is not possible)

If no function is desired for a logic variable, type NA <ENTER>.

To fully utilize the relay's resources, self-tests are delayed when any of the following elements are picked up:

51P, 50H, 51GP, 50G, 51NP, 50NL, 50NH  
 51T, 51GT, 50GT, 51NT, and 50NLT.

Therefore, you should be careful to set the relay so that under normal conditions none of these elements are picked up.

When you finish entering setting changes, you need not scroll through the remaining settings. Type **END <ENTER>** after your last change to display the new settings and enable prompt. Do not use the END statement at the Relay ID setting; use **<CTRL>X** to abort the SET procedure from this point.

After you enter all data, the relay displays new group and global settings and prompts for approval to enable new group settings. Answer **Y <ENTER>** to approve the new settings; the relay enables them and clears the event buffer. If the active group is the same as the one you are setting, the ALARM output pulses closed.

A list of relay settings follow. Setting ranges and explanations have been added.

=>>**SET 1 <ENTER>**

SET clears events. CTRL-X cancels.

SEL-251D-1-R400 Group Settings

Group = 1

Active group = 1

Enter data, or **<ENTER>** for no change

			<u>Range</u>
ID	: Example 21.6 kV distribution feeder	?	39 characters
CTR	: ..... = 120.00	?	0.001-10000
	Current transformer ratio		
PTR	: ..... = 180.00	?	"
	Potential transformer ratio		
R1	: Ohms Pri ..... = 0.58	?	0.001-10000
	Positive-sequence line resistance		
X1	: ..... = 1.50	?	"
	Positive-sequence line reactance		
R0	: ..... = 1.44	?	"
	Zero-sequence line resistance		
X0	: ..... = 4.56	?	"
	Zero-sequence line reactance		
R0S	: ..... = 0.00	?	"
	Zero-sequence source resistance		



**X0S** : ..... = 0.00 ? "  
 Zero-sequence source reactance

**LL** : Line Len ..... = 2.42 ? 0.001-10000  
 Line length (unitless); If LL=0.001, no fault location information

**DATC** : Dem, 5-60 min ..... = 15 ?  
 Demand ammeter time constant

**PDEM** : Ph Dem Thr, A sec ..... = 12.00 ? 1.00-12.00  
 Phase demand ammeter threshold for **PDEM**

**NDEM** : IR Dem Thr, A sec ..... = 12.00 ? "  
 Ground/residual demand ammeter threshold for **NDEM**

**79OI1** : Open Int 1, cyc ..... = 30 ? 0-16000  
 Reclosing relay open interval time no. 1  
 79OI1=0 defeats reclosing

**79OI2** : ..... = 0 ? "  
 Reclosing relay open interval time no. 2

**79OI3** : ..... = 0 ? "  
 Reclosing relay open interval time no. 3

**79OI4** : ..... = 0 ? "  
 Reclosing relay open interval time no. 4

**79RST** : Reset Int, cyc ..... = 1800 ? "  
 Reclosing relay reset interval time

**M79SH** : Shot Mask ..... = 10000 ? 00000 to 11111 binary  
 Reclosing relay shot mask: designate **79SH** bit assertion for shots 0, 1, 2, 3, or 4

**50C** : A sec ..... = 99.99 ? 0.50-100.00  
 Pickup for phase instantaneous overcurrent element **50C**  
**50C** operates on "2 out of 3" logic:  
 $50C = 50C_A * 50C_B + 50C_B * 50C_C + 50C_C * 50C_A$

**27L** : V l-l sec ..... = 0.00 ? 0-140  
 Low-set limit for undervoltage element **27**

**27H** : V l-l sec ..... = 0.00 ? "  
 High-set limit for undervoltage element **27**

**27C** : 2, 3 Ph or 4 = HS Blown Fuse ..... = 2 ?  
 Select whether **27** is a phase-to-phase or three phase-to-phase element, or select 4 to enable blown-fuse detection

TCI : 0=none, V=27, I=50C, 3=both . . . = 0 ?  
Internal torque control conditions

50G : A sec . . . . . = 99.99 ? 0.50-100.00  
Pickup for ground/residual definite-time overcurrent element **50GT**

50GT : Dly, cyc . . . . . = 0 ? 0-16000  
Time delay for ground/residual definite-time overcurrent element **50GT**

51GP : A sec . . . . . = 12.00 ? 1.00-12.00  
Pickup for ground/residual time-overcurrent element **51GT**

51GTD : Time Dial . . . . . = 15.00 ? 0.50-15.00  
Time dial for ground/residual time-overcurrent element **51GT**

51GC : Curve 1,2,3,4 or 5 . . . . . = 4 ?  
Curve for ground/residual time-overcurrent element **51GT**  
1=moderately inverse, 2=inverse, 3=very inverse, 4=extremely inverse,  
5=short-time inverse

51GRS : Dly Reset Y/N? . . . . . = N ?  
Time delay reset for ground/residual time-overcurrent element **51GT**?  
(If N, **51GT** resets 1 cycle after **51GP** drops out)

50NL : A sec . . . . . = 2.01 ? 0.125-100.00  
Pickup for ground/residual definite-time overcurrent element **50NLT**  
Setting range dependent on 51NP setting.

50NLT : Dly, cyc . . . . . = 0 ? 0-16000  
Time delay for ground/residual definite-time overcurrent element **50NLT**

50NH : A sec . . . . . = 39.99 ? 0.125-100.00  
Pickup for ground/residual instantaneous overcurrent element **50NH**  
Setting range dependent on 51NP setting.

51NP : A sec . . . . . = 1.50 ? 0.25-12.00  
Pickup for ground/residual time-overcurrent element **51NT**

51NTD : Time Dial . . . . . = 3.00 ? 0.50-15.00  
Time dial for ground/residual time-overcurrent element **51NT**

51NC : Curve 1,2,3,4 or 5 . . . . . = 4 ?  
Curve for ground/residual time-overcurrent element **51NT**  
1=moderately inverse, 2=inverse, 3=very inverse, 4=extremely inverse  
5=short-time inverse

51NRS : Dly Reset Y/N? . . . . . = N ?  
Time delay reset for ground/residual time-overcurrent element **51NT**?  
(If N, **51NT** resets 1 cycle after **51NP** drops out)

50L : A sec . . . . . = 99.99 ? 0.50-100.00  
Pickup for phase definite-time overcurrent element **50LT**

50LT : Dly, cyc . . . . . = 0 ? 0-16000  
Time delay for phase definite-time overcurrent element **50LT**

50H : A sec . . . . . = 39.99 ? 0.50-100.00  
Pickup for phase instantaneous overcurrent element **50H**

51P : A sec . . . . . = 6.00 ? 1.00-12.00  
Pickup for phase time-overcurrent element **51T**

51TD : Time Dial . . . . . = 5.00 ? 0.50-15.00  
Time dial for phase time-overcurrent element **51T**

51C : Curve 1,2,3,4 or 5 . . . . . = 4 ?  
Curve for phase time-overcurrent element **51T**  
1=moderately inverse, 2=inverse, 3=very inverse, 4=extremely inverse  
5=short-time inverse

51RS : Dly Reset Y/N? . . . . . = N ?  
Time delay reset for phase time-overcurrent element **51NT?**  
(If N, **51T** resets 1 cycle after **51P** drops out)

52APU : 52A PU, cyc . . . . . = 0 ? 0-16000  
Time delay pickup for **52AT**

52ADO : 52A DO, cyc . . . . . = 0 ? "  
Time delay dropout for **52AT**

TSPU : Tmr PU, cyc . . . . . = 0 ? "  
Timer TS time delay pickup (timer TS output is Relay Word bit **ST**)

TSDO : Tmr DO, cyc . . . . . = 0 ? "  
Timer TS time delay dropout (timer TS output is Relay Word bit **ST**)

TKPU : . . . . . = 1 ? "  
Timer TK time delay pickup (timer TK output is Relay Word bit **KT**)

TKDO : . . . . . = 0 ? "  
Timer TK time delay dropout (timer TK output is Relay Word bit **KT**)

TZPU : . . . . . = 0 ? "  
Timer TZ time delay pickup (timer TZ output is Relay Word bit **ZT**)

TZDO : . . . . . = 0 ? "  
Timer TZ time delay dropout (timer TZ output is Relay Word bit **ZT**)

Set remaining settings equal to combinations of elements in the Relay Word via SELOGIC Control Equations. You can clear logic settings by entering NA.

The following settings S(123) through A2(1234) can be set to equal any OR-combination of elements in the Relay Word rows indicated in parentheses.

S(123) = ? Input into timer TS (TS output is Relay Word bit **ST**)

Settings A(12) through J(1234) are for Relay Word bits **A** through **J**, respectively.

A(12) = 50NL ?

B(12) = 50NH+51NT ?

C(12) = ?

D(12) = ?

E(34) = ?

F(34) = ?

G(34) = ?

H(34) = IN6 ?

J(1234) = 79SH ?

K(1234) = IN5 ? Input into timer TK (TK output is Relay Word bit **KT**)

L(1234) = ? Input into an inverter (output is Relay Word bit **!L**)

A1(1234) = ? A1 output contact setting

A2(1234) = ? A2 output contact setting

The following settings V(56) through Z(56) can be set to equal any AND-combination of Relay Word bits **A** through **!L**, which are in Relay Word row **R5** and the first three bits of row **R6**.

V(56) = A\*H\*J ?

W(56) = B\*H ?

X(56) = J\*KT ?

Y(56) = ?

Z(56) = ? Input into timer TZ (TZ output is Relay Word bit **ZT**)

The following settings A3(1346) through SEQ(1) can be set to equal any OR-combination of elements in the Relay Word rows indicated in parentheses.

A3(1346) = ? A3 output contact setting

A4(2346) = ? A4 output contact setting\*

TR(1246) = 50H+51T+V+W+X ? Programmable tripping conditions

RC(1246) = ? Programmable reclose cancel conditions

ER(1246) = ? Programmable event report trigger conditions

SEQ(1) = ? Sequence coordination overcurrent pickup(s)

\* The A4 output contact can function as an extra ALARM output contact, depending on the placement of jumper JMP3. With jumper JMP3 in the A4 position, the A4 output contact operates per setting A4(2346). With jumper JMP3 in the ALARM position, the A4 output contact operates with the ALARM output contact.

**Note:** SELOGIC Control Equations cannot exceed 90 characters per equation (including + or \* characters). Exceeding this limit may overflow the relay input buffer and cause it to XOFF the terminal from which you are entering settings (see Communications Protocol in this section).

The following settings specify overcurrent elements in Relay Word row R1 to be torque controlled (e.g., ETC(1) = **51P,50NL**).

ETC(1) = 51P ? Externally torque controlled elements  
 ITC(1) = ? Internally torque controlled phase overcurrent elements (choose from **51P,50L, and 50H** only)

**Refer to the functional description and be sure the group settings you choose result in relay performance appropriate to your application.**

### SET G p

SET G allows entry of global settings which are used with all setting groups. At the setting procedure prompts, enter new data or press <ENTER> for no change. You can jump to a specific global setting by entering the setting name as parameter p. If you do not specify a setting, the procedure starts at the first global setting DEMR.

The relay prompts you for each global setting and checks entries against established limits as it does during group setting entry (see SET n p in this section). For the programmable contact inputs IN1 to IN6, if no function is desired, type NA <ENTER>. Type END <ENTER> after the last setting change. The relay displays the new global settings and the active group settings. Answer Y <ENTER> to enable the new global settings. The relay will pulse the ALARM output as the new global settings are stored in memory.

Following is a list of global settings with setting ranges and explanations.

= > > SET G <ENTER>

SET clears events. CTRL-X cancels.

SEL-151-R400 Global Settings

Enter data, or <ENTER> for no change

		<u>Range</u>
DEMR	: Dem Reset Grp Chg Y/N? . . . . . = Y ? Reset the demand values when an active setting group change is made.	
CFT	: Cl Fail Time, cyc . . . . . = 0 ? Close failure time. If CFT = 0, CLOSE output contact deasserts if breaker closes per circuit breaker status input (52A, !52A, 52AR, or !52AR) or TRIP output contacts assert.	0-16000
TDUR	: Trip Dur, cyc . . . . . = 4 ? Trip duration time	0-63

- TFT : Trip Fail Time, cyc . . . . . = 0 ? "
- Trip failure time
- TGR : Grp Chg Dly, cyc . . . . . = 180 ? 0-16000  
Setting Group Selection inputs (SS1, SS2, SS3) have to stabilize for time TGR before the relay changes setting groups.
- ITT : Inst Tar Time, cyc . . . . . = 5 ? 0-63  
INST front panel target illuminates if TRIP occurs less than ITT time after any Relay Word row R1 overcurrent element picks up. Setting ITT=0 defeats the INST target.
- TIME1 : Port 1 Timeout, min . . . . . = 15 ? 0-30  
(=0, no timeout)
- TIME2 : Port 2 Timeout, min . . . . . = 0 ? "  
(=0, no timeout)
- AUTO : Autoport 1,2 or 3 . . . . . = 2 ?  
1 = Port 1, 2 = Port 2, and 3 = both  
Port to receive automatic messages
- RINGS : Rings 1-30 . . . . . = 3 ?  
Number of rings after which modem on Port 1 answers

Inputs IN1 through IN6 can be assigned to one of the following functions:

- SS1 Setting Group Selection Input 1 (assign to IN1 only)  
SS2 Setting Group Selection Input 2 (assign to IN2 only)  
SS3 Setting Group Selection Input 3 (assign to IN3 only)
- TCP External Torque Control (Phase and Negative-Sequence Elements)  
!TCP (inverted sense of TCP)
- TCG External Torque Control (Residual Overcurrent Elements)  
!TCG (inverted sense of TCG)
- 52A Circuit Breaker Status (52A contact input)\*  
!52A Circuit Breaker Status (52B contact input)\*  
52AR Circuit Breaker Status (52A contact input)/Reclose Initiate\*  
!52AR Circuit Breaker Status (52B contact input)/Reclose Initiate\*
- DC Direct Close (requires circuit breaker status)  
RE Reclose Enable (requires circuit breaker status)  
!RE !RE (inverted sense of RE) (requires circuit breaker status)  
TCM Trip Circuit Monitor (requires circuit breaker status)

ET External Trigger of Event Report  
DT Direct Trip  
(blank) Unassigned Input

Type NA <ENTER> to clear settings.

IN1 = SS1 ?  
IN2 = DT ?  
IN3 = RE ?  
IN4 = ?  
IN5 = 52A ?  
IN6 = ?

\* Only one of the circuit breaker status input options 52A, !52A, 52AR, or !52AR should be assigned to an input.

#### **52A or !52A**

If 52A or !52A is assigned to an input, only circuit breaker status information is provided. Reclose initiation is provided by the assertion of the internal TRIP condition. When the TRIP condition drops out and the circuit breaker is open (per 52A or !52A), the open interval starts timing.

#### **52AR or !52AR**

If 52AR or !52AR is assigned to an input, not only does the input provide circuit breaker status information, but it provides reclose initiation, too. The sensed transition of the circuit breaker status, indicating that the circuit breaker is opening, initiates reclosing. If the TRIP condition is present, it has to drop out before the open interval starts timing.

In most applications, circuit breaker trips external to the relay (e.g., by control switch or SCADA) must not cause reclose initiation. If input option RE (Reclose Enable) is assigned to an input, the RE input is de-energized to prevent automatic reclosing. Certain control switch contacts can be wired to the RE input to defeat reclosing for control switch trips.

Also, if 52AR or !52AR is assigned to an input, the circuit breaker status function is time delayed by 10 cycles to qualify circuit breaker opening. This is done for certain application needs (see SYSTEM RESTORATION AFTER UNDERFREQUENCY LOAD-SHEDDING in Section 5: APPLICATIONS). If this type of application is not needed, then it is better to assign 52A or !52A to an input instead and avoid the 10-cycle time delay. This time delay shows up in event reports and needs to be accounted for when making setting 52ADO.

The 10-cycle delay affects the circuit breaker monitor, too. The TDUR timer should be set somewhat greater than 10 cycles so that relay initiated circuit breaker trips are counted as such and not as external circuit breaker trips. Also, if an external trip occurs, no interrupted current values will likely be accumulated by the circuit breaker monitor because of the 10-cycle time delay.

**Refer to the functional description and be sure the global settings you choose result in relay performance appropriate to your application.**

The AUTO setting selects Port 1, Port 2, or both serial ports for automatically transmitted messages. If relay Port 2 is connected to an SEL-RD or SEL-PRTU, the AUTO setting must direct automatic messages to that port. The following table shows the effect of each possible setting:

<b><u>Auto Setting</u></b>	<b><u>Automatic Message Destination Port</u></b>
1	1
2	2
3	1 and 2

Event summaries and self-test warning and failure reports are automatically transmitted from port(s) designated automatic regardless of access level if the designated port is not timed out. Enter zero as the timeout setting of the appropriate port if automatic transmissions will be monitored by a dedicated channel or printed on a dedicated printer.



# SEL-251D-1 RELAY COMMAND SUMMARY

## Access Level 0

**ACCESS** Answer password prompt (if password protection is enabled) to enter Access Level 1. Third unsuccessful attempt pulses ALARM contacts closed for one second.

## Access Level 1

**2ACCESS** Answer password prompt (if password protection is enabled) to enter Access Level 2. This command always pulses the ALARM contacts closed for one second.

**BREAKER** Displays running sum of circuit breaker trips for relay and external trips (circuit breaker trip counters). Also displays running sum of interrupted current in each circuit breaker pole for relay and external trips. Current values are displayed in kA (kiloamperes).

**BREAKER R** Resets circuit breaker trip counters and interrupted current sums to zero for both relay and external trips. Relay stores reset date and time.

**DATE m/d/y** Sets or displays date. DAT 4/1/93 sets date to April 1, 1993. IRIG-B time code input overrides existing month and day settings. DATE pulses ALARM contacts when year entered differs from year stored. To display the date only, enter DATE.

**EVENT n** Shows event record. EVE or EVE 1 shows newest event; EVE 12 shows oldest (n=1, 2, 3,...,11, or 12).

**HISTORY** Shows DATE, TIME, EVENT, LOCAT (location), SHOT, TARGETS, and CURR (maximum fault current) for the last twelve events.

**IRIG** Forces immediate attempt to synchronize internal relay clock to time code input.

**METER n** Displays present phase and residual current values; present real and reactive power values; present line-to-line voltage values. Optional n displays METER data n times.

**METER D** Displays demand and peak demand values of phase and residual current values and real and reactive power values.

**METER RD** Resets demand values.

**METER RP** Resets peak demand values.

**QUIT** Returns control to Access Level 0; returns target display to Relay Targets.

**SHOWSET n** Displays settings of setting group n without affecting them (n = 1, 2, 3, 4, 5, or 6).

**STATUS** Shows self-test status.

**TARGET n k** Shows data and sets target LEDs as follows (n = 0, 1, 2, . . . 7, or 8):

TAR 0: Front Panel Targets	TAR 1: Relay Word row R1
TAR 2: Relay Word row R2	TAR 3: Relay Word row R3
TAR 4: Relay Word row R4	TAR 5: Relay Word row R5
TAR 6: Relay Word row R6	TAR 7: Input States
TAR 8: Output Contact States	Optional k displays target data k times.

TARGET R Clears targets and returns to TAR 0

TIME h/m/s Sets or displays time. TIM 13/32/00 sets clock to 1:32:00 PM. IRIG-B synchronization overrides this setting. To display the time only, enter TIME.

TRIGGER Triggers and saves an event record (event type is EXT).

## **Access Level 2**

CLOSE Closes circuit breaker, if allowed by jumper setting.

COPY m n Copies setting group m to setting group n (m and n equal any combination of 1, 2, 3, 4, 5, or 6). Clears buffers. If n is the active setting group, the ALARM output contacts pulse closed.

GROUP n Designates the active setting group when no Setting Group Selection Inputs are assigned to inputs or all Setting Group Selection Inputs assigned to inputs are deasserted (n = 1, 2, 3, 4, 5, or 6). The ALARM output contacts pulse closed when the active group changes. GROUP n command execution does not clear the event buffer.

OPEN Opens circuit breaker, if allowed by jumper setting.

PASSWORD Shows or sets passwords. ALARM contacts pulse closed after password entry. PAS 1 OTTER sets Level 1 password to OTTER. PAS 2 TAIL sets Level 2 password to TAIL.

SET n p Initiates setting procedure for setting group n (n = 1, 2, 3, 4, 5, or 6). Option p directs the relay to begin the setting procedure for setting group n at setting p (e.g., if p = 51P, the setting procedure starts at setting 51P, bypassing all settings before 51P). If no optional p is entered, the setting procedure starts at the beginning.

The relay clears event buffers when new settings are stored. If n is the active setting group, the ALARM output contact pulses closed.

SET G p Initiates setting procedure for the global setting group. Option p directs the relay to begin the setting procedure for the global setting group at setting p (e.g., if p = TDUR, the setting procedure starts at setting TDUR, bypassing all settings before TDUR). If optional p is not used, the setting procedure starts at the beginning.

The SET G command pulses ALARM contacts closed and clears event buffers when new settings are stored.

**EVENT REPORTING  
TABLE OF CONTENTS**

---

Event Report Generation . . . . . 4-1  
Summary Event Report . . . . . 4-1  
Long Event Report . . . . . 4-2  
Interpreting Voltage and Current Data . . . . . 4-2  
Relay Element, Output Contact, and Input Data . . . . . 4-4  
Example Event Reports . . . . . 4-5  
Firmware Identification . . . . . 4-10

**TABLES**

Table 4.1: Event Report Triggering Actions . . . . . 4-1



# EVENT REPORTING

---

## EVENT REPORT GENERATION

The relay generates a summary and long event report in response to the actions listed in Table 4.1. The summary event report allows a quick review of the information necessary to determine fault type and location. The long event report displays eleven cycles of information for analyzing system and scheme performance.

**Table 4.1: Event Report Triggering Actions**

- Programmable event report triggering variable (ER) assertion
- TRIGGER command execution
- ET (External Trigger) input assertion
- TRIP output contact assertion

The relay generates a second summary and long event report for the same fault if the trip occurs after the end of the first report.

Relay elements which trigger event reports must drop out for at least four cycles before they can initiate another event report. This helps to eliminate multiple records for boundary faults.

Triggering is recorded to the nearest quarter-cycle and referenced to the 16th row of data in the report. All reports trigger at row 16. This system allows you to determine the total duration of a long fault which triggers two event reports. Simply calculate the time difference between the report generated at fault inception by ER (the programmable event report triggering variable) and the report generated by the TRIP.

## SUMMARY EVENT REPORT

The summary report is automatically transmitted from port(s) designated AUTOMATIC regardless of access level, as long as the designated port has not timed out. If automatic transmissions are monitored by a dedicated channel or printed on a dedicated printer, enter zero for the timeout setting of the appropriate port.

Due to the length of the full report, it is not automatically transmitted. You can display the full report with the EVENT command.

The summary event report includes:

- Relay terminal identifier
- Date and time
- Event type
- Fault location
- Reclosing relay shot
- FAULT TYPE front panel targets
- Currents (phase, 3 x negative-sequence, and residual) measured near the middle of the fault or when the event report was triggered if no fault occurred.

The following shows an example summary event report.

```
Example 21.6 kV distribution feeder Date: 04/01/93 Time: 01:36:50.070
Event   : AG T   Location: 2.43   Shot: 0   Targets: INSTAG
Currents (A pri), ABCG: 2798   213   211   2742
=>
```

See HISTORY in Section 3: COMMUNICATIONS for more information. The relay clears the event report and history buffer for the following conditions:

- Loss of control power
- Entry of new setting via SET or SET G command
- COPY command execution

## LONG EVENT REPORT

The long event report contains 44 quarter-cycles of pre-fault, fault, and post fault voltage and current information. For each quarter-cycle of information, the relay also records the states of all fault measuring elements, outputs, and inputs. The report also includes settings active during the event. This information is useful in reviewing fault inception and duration, relay element response, fault evolution, and breaker reaction time.

The last twelve event records are stored in volatile memory. You can review the stored summary reports quickly with the HISTORY command; use the EVENT command to display the long form of each event report.

## INTERPRETING VOLTAGE AND CURRENT DATA

The relay determines voltage and current data in the event report using the following steps. The process uses secondary quantities presented to the rear panel of the relay.

1. Two-pole, low pass filters with cutoff frequencies of approximately 85 Hz filter input analog signals.
2. The relay samples filtered analog signals four times per power system cycle and converts them to numerical values.
3. A digital filter processes the sampled data and removes dc and ramp components. The unit sample response of this filter is:

$$1, -1, -1, 1$$

The filter has the property of a double differentiator smoother.

4. The digital filter processes the latest four samples every quarter-cycle. Successive filter outputs arrive every  $90^\circ$ . With respect to the present value of the filter output, the previous value was taken one quarter-cycle earlier and appears to be leading the present value by  $90^\circ$ .

Filter output values can be used to represent the signals as phasors:

The previous value of the output is the Y-component.  
The present value of the output is the X-component.

The following example illustrates why the older data is the leading component of the phasor.

Consider a sinewave having zero-phase shift with respect to  $t = 0$  and a peak amplitude of 1. Now consider two samples, one taken at  $t = 0$ , the other taken  $90^\circ$  later. They have values 0 and 1, respectively. By the above rules, the phasor components are  $(X,Y) = (1,0)$ .

Now consider a cosine function. Its samples taken at  $t = 0$  and  $t+90^\circ$  are 1 and 0; its phasor representation is  $(0,1)$ . The phasor  $(0,1)$  leads the phasor  $(1,0)$  by  $90^\circ$ . This coincides with a  $90^\circ$  lead of the cosine function over the sine function.

To construct a phasor diagram of voltages and currents, select a pair of adjacent rows from an area of interest in the event report. On Cartesian coordinates, plot the lower row (newer data) as the X-components and the upper row (older data) as the Y-components. Rotate the completed diagram to any angle of reference. The magnitude of any phasor equals the square root of the sum of its squares.

Note that moving forward one quarter-cycle rotates all phasors  $90^\circ$ . You can verify this by plotting the phasor diagram with rows 1 and 2, then rows 2 and 3 of an event report. Example Event Report 1 shows conversion of the rectangular format voltages and currents displayed in the event report to polar format (see Example Event Reports).

# RELAY ELEMENT, OUTPUT CONTACT, AND INPUT DATA

Relay elements, inputs, and output contact states appear in the right-hand columns of the event report. The following information lists symbols corresponding to asserted combinations of elements ("1" indicates element/output contact assertion or input energization).

Event Report Column	Elements	Symbol	Event Report Column	Elements	Symbol
<u>P</u>	Phase overcurrent		<u>N</u>	Ground/residual overcurrent	
51	51P 51T 0 0 0 1 1 0 1 1	. 1 p T	51	51NP 51NT 0 0 0 1 1 0 1 1	. 1 p T
50L	50L 50LT 0 0 0 1 1 0 1 1	. (not possible) p T	50L	50NL 50NLT 0 0 0 1 1 0 1 1	. (not possible) p T
50H	50H 0 1	. p	50H	50NH 0 1	. p
TCI	Internal torque control		<u>I</u>	Demand current thresholds	
	50C 27 0 0 0 1 1 0 1 1	. V I 3	DEM	PDEM NDEM 0 0 0 1 1 0 1 1	. N P 5
<u>G</u>	Ground/residual overcurrent		79	Reclosing relay states	
51	51GP 51GT 0 0 0 1 1 0 1 1	. 1 p T	79RS 79CY 79LO	0 0 0 0 0 1 0 1 0 0 1 1 1 0 0 1 0 1 1 1 0 1 1 1	.(no 52A or !52A) L C (not possible) R (not possible) (not possible) (not possible)
50	50G 50GT 0 0 0 1 1 0 1 1	. (not possible) p T			



<u>Event Report Column</u>	<u>Elements</u>	<u>Symbol</u>	<u>Event Report Column</u>	<u>Elements</u>	<u>Symbol</u>		
BKR	Circuit breaker alarms			3&4	A3	A4	
					0	0	.
					0	1	4
	TF	CF	TCMA		1	0	3
	0	0	0		1	1	B (Both)
	0	0	1				
	0	1	0		ALR	Alarm	
	0	1	1		0		.
	1	0	0		1		A
	1	1	0				
		1					
		7					
<u>Out</u>	Output contacts						
T&C	TRIP	CLOSE		1&2	IN2	IN1	
	0	0	.		0	0	.
	0	1	C		0	1	1
	1	0	T		1	0	2
	1	1	(not possible)		1	1	B (Both)
1&2	A1	A2		3&4	IN4	IN3	
	0	0	.		0	0	.
	0	1	2		0	1	3
	1	0	1		1	0	4
	1	1	B (Both)		1	1	B (Both)
			5&6	IN6	IN5		
				0	0	.	
				0	1	5	
				1	0	6	
				1	1	B (Both)	

## EXAMPLE EVENT REPORTS

### Externally Triggered Event Report

Recall from Section 3: COMMUNICATIONS that the relay records an eleven-cycle event report when you issue the TRIGGER command. This command does not affect the protective functions of the relay. The event type listing "TRIG" signifies an event triggered on command. Use the TRIGGER command to generate an event report for plotting voltage and current phasors during normal load conditions prior to releasing the relay for service.

Example Event Report 1 shows the first cycle of an event report triggered under normal operating conditions for a 21.6 kV distribution feeder. The report was generated with the TRIGGER command. In this excerpt, you can immediately see that load currents are balanced by the lack of significant current in the residual current column IR. Also, note that the line breaker is closed, as signified by a "4" in the column labeled In: 3 & 4 (IN4 = 52A).

Event report data for the voltages and currents appears in rectangular format. You can easily convert these rectangular values to polar format as described in Interpreting Voltage and Current Data. Section 6: INSTALLATION includes a blank voltage and current polarity check form for plotting voltage and current phasors. A direction and polarity check form completed using the first two rows of data from the event report appears on the following page for the phase currents.

Using the voltage and current phasor diagrams on the bottom of the SEL Direction and Polarity Check Form, note that the current phase rotation is ABC in the counterclockwise direction. This phase rotation must match that of your system.

### **Fault Triggered Event Report**

Example Event Report 2 shows all eleven cycles of a fault triggered event report. The first two cycles show prefault conditions. The event report was triggered when tripping condition V came true [programmable tripping variable  $TR(1246)=...+V+...$ ]. Comments to the right of the event report and settings explain additional details.

## Example Event Report 1

Example 21.6 kV distribution feeder      Date: 8/1/93      Time: 01:07:35.862

FID=SEL-251D-1-R400-V656rp1ggd-D930719-E2

Currents (A pri)				Voltages (V pri)			P	G	N	I	Out	In
IR	IA	IB	IC	VAB	VBC	VCA	555T	55	555 D	7B	T13A	135
-1	310	-171	-141	17251	2632	-19883	100C	10	100 E	9K	&&&L	&&&
3	16	262	-276	-12999	21439	-8440	LHI		LH M	R	C24R	246
1	-310	171	141	-17251	-2632	19883						
-3	-16	-262	276	12999	-21439	8440						
										R.	....	.4.
										R.	....	.4.
										R.	....	.4.
										R.	....	.4.

One cycle of data

Event : TRIG    Location :                      Shot: 0    Targets:                      \_\_\_\_\_    Event Summary  
 Currents: (ABCG amps, primary)    310    313    310    3

### SEL DIRECTION AND POLARITY CHECK FORM

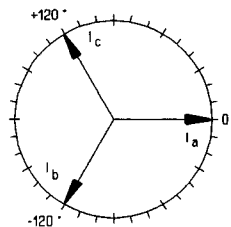
STATION 21.6 KV DISTRIBUTION FEEDER      DATE: 08 / 01 / 93    TESTED BY \_\_\_\_\_  
 SWITCH NO. \_\_\_\_\_ EQUIPMENT \_\_\_\_\_  
 INSTALLATION \_\_\_\_\_ ROUTINE \_\_\_\_\_ OTHER \_\_\_\_\_

**LOAD CONDITIONS:**

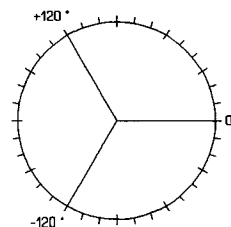
STATION READINGS: \_\_\_\_\_ MW (OUT)(IN)    \_\_\_\_\_ MVAR (OUT)(IN)    \_\_\_\_\_ VOLTS    \_\_\_\_\_ AMPS  
 SEL READINGS: \_\_\_\_\_ MW (+)(-)    \_\_\_\_\_ MVAR (+)(-)

AS SEEN ON SCREEN	Ia	Ib	Ic	Va	Vb	Vc
COMPANY NOTATION	I()	I()	I()	V()	V()	V()
1st LINE CHOSEN (Y COMPONENT)	310	-171	-141			
2nd LINE CHOSEN (X COMPONENT)	16	262	-276			
<b>CALCULATED</b>						
MAGNITUDE $\sqrt{X^2 + Y^2}$	310	313	310			
ANGLE IN DEGREES ARCTAN Y/X	87	-33	-153			
VALUE OF Va DEGREES TO SUBTRACT TO OBTAIN Va DEGREES = 0	-87	-87	-87			
Ⓢ Va DEGREES = 0, ANGLE USED TO DRAW PHASOR DIAGRAM	0	-120	-240			

USE THE VALUES IN ROWS 1 AND 2 ABOVE TO DRAW PHASOR DIAGRAMS BELOW



CURRENTS



VOLTAGES

DWG. 1000-718

## Example Event Report 2

Example 21.6 kV distribution feeder

Date: 8/1/93

Time: 01:36:59.070

Time-tag corresponds to the 16th quarter-cycle of this event report.

FID=SEL-251D-1-R400-V656rp1ggd-D930719-E2

Currents (A pri)				Voltages (V pri)			P	G	N	I	Out	In
IR	IA	IB	IC	VAB	VBC	VCA	555T 100C LHI	55 10	555 D 100 E LH M	7B 9K R	T13A &&&L C24R	135 &&&
0	98	-296	198	16786	-20165	3379	....	....	....	R.	....	.4.
4	287	-59	-225	13593	7741	-21334	....	....	....	R.	....	.4.
0	-98	296	-198	-16786	20165	-3379	....	....	....	R.	....	.4.
-4	-287	59	225	-13593	-7741	21334	....	....	....	R.	....	.4.
0	98	-296	198	16786	-20165	3379	....	....	....	R.	....	.4.
4	287	-59	-225	13593	7741	-21334	....	....	....	R.	....	.4.
0	-98	296	-198	-16786	20165	-3379	....	....	....	R.	....	.4.
-4	-287	59	225	-13593	-7741	21334	....	....	....	R.	....	.4.
0	98	-296	198	16786	-20165	3379	....	....	....	R.	....	.4.
4	287	-59	-225	13593	7741	-21334	....	....	....	R.	....	.4.
296	200	285	-191	-16418	20023	-3605	....	....	....	R.	....	.4.
-206	-468	47	215	-11618	-7706	19324	....	..	pp.	R.	....	.4.
-1254	-1168	-247	164	15149	-19940	4791	....	..	pp.	R.	....	.4.
903	1123	-36	-185	8618	7891	-16509	p....	p.	pp.	R.	....	.4.
2067	1991	215	-143	-13810	19936	-6126	p....	p.	pp.	R.	....	.4.
-1460	-1655	38	164	-7320	-8009	15329	p....	p.	pp.	R.	T....	.46
-2267	-2192	-211	138	13747	-19919	6172	p....	p.	pp.	R.	T....	.46
1537	1728	-36	-160	7279	7976	-15255	p....	p.	pp.	R.	T....	.46
2268	2193	210	-138	-13747	19919	-6172	p....	p.	pp.	C.	T....	.46
-1538	-1731	36	160	-7279	-7976	15255	p....	p.	pp.	C.	T....	.46
-2272	-2195	-210	138	13747	-19919	6172	p....	p.	pp.	C.	T.3.	.46
1540	1737	-36	-160	7279	7976	-15255	p....	p.	pp.	C.	T.3.	.46
2272	2193	210	-138	-13747	19919	-6172	p....	p.	pp.	C.	T.3.	.46
-1540	-1737	36	160	-7279	-7976	15255	p....	p.	pp.	C.	T.3.	.46
-2256	-2183	-210	138	13747	-19919	6172	p....	p.	pp.	C.	T.3.	.46
1513	1703	-36	-160	7279	7976	-15255	p....	p.	pp.	C.	T.3.	.46
1754	1761	201	-135	-13956	19924	-5968	p....	p.	pp.	C.	T.3.	.46
-541	-552	125	42	-9219	-7884	17103	p....	p.	pp.	C.	T.3.	.46
-214	-231	-17	19	15487	-19843	4356	....	..	pp.	C.	T.3.	.46
17	19	-7	-2	13481	7781	-21262	....	..	pp.	C.	T.3.	.46
9	10	1	-1	-16719	20136	-3417	....	..	pp.	C.	T.3.	.46
-2	-2	0	0	-13596	-7700	21296	....	..	pp.	C.	T.3.	.46
-1	-1	0	0	16786	-20165	3379	....	..	pp.	C.	T.3.	.46
0	0	0	0	13593	7741	-21334	....	..	pp.	C.	T.3.	.46
0	0	0	0	-16786	20165	-3379	....	..	pp.	C.	T.3.	.46
0	0	0	0	-13593	-7741	21334	....	..	pp.	C.	T.3.	.46
0	0	0	0	16786	-20165	3379	....	..	pp.	C.	T.3.	.46
0	0	0	0	13593	7741	-21334	....	..	pp.	C.	T.3.	.46
0	0	0	0	-16786	20165	-3379	....	..	pp.	C.	T.3.	.46
0	0	0	0	-13593	-7741	21334	....	..	pp.	C.	T.3.	.46

One cycle of data

Input 4 is energized (4)  
IN4=52A; breaker closed

Reclosing relay is in the reset state (R; 79RS = 1)

50NL picks up and other time-overcurrent elements start timing at fault inception (p)

Trip condition V comes true when input 6 is energized (6)  
A=50NL H=IN6  
J=79SH (=1 for shot 0)  
V=A\*H\*J  
TR=...+V+...  
TRIP output contact asserts (T) and this event report is generated

52A input drops out (IN4 = 52A) indicating that the circuit breaker is opening

All overcurrent elements drop out after the circuit breaker interrupts the fault current

TRIP output contact (T) is asserted for a minimum of 4 cycles (TDUR = 4)

Reclosing relay is in the reclose cycle state (C; 79CY = 1)

Event : AG T Location: 2.43 Shot: 0 Targets: INSTAG  
Currents (A pri), ABCG 2798 213 211 2742

Event Summary

## Example Event Report 2, Continued

### Settings for Group 1

#### Example 21.6 kV distribution feeder

CTR =120.00	PTR =180.00			
R1 =0.58	X1 =1.50	R0 =1.44	X0 =4.56	
ROS =0.05	XOS =0.53	LL =2.42		
DATC =15	PDEM =12.00	NDEM =12.00		
790I1=30	790I2=0	790I3=0	790I4=0	
79RST=1800	M79SH=10000			
50C =99.99	27L =0.00	27H =0.00	27C =2	TCI =0
50G =99.99	50GT =0			
51GP =12.00	51GTD=15.00	51GC =4	51GRS=N	
50NL =2.01	50NLT=0	50NH =39.99		
51NP =1.50	51NTD=3	51NC =4	51NRS=N	
50L =99.99	50LT =0	50H =39.99		
51P =6	51TD =5	51C =4	51RS =N	
52APU=0	52ADO=0	TSPU =0	TSDO =0	
TKPU =1	TKDO =0	TZPU =0	TZDO =0	

One-cycle pickup time for timer TK

#### SELogic Equations

S(123) =  
A(12) =50NL  
B(12) =50NH+51NT  
C(12) =  
D(12) =  
E(34) =  
F(34) =  
G(34) =  
H(34) =IN6 \_\_\_\_\_ Input IN6 functions as a permissive trip input  
J(1234) =79SH  
K(1234) =IN5 \_\_\_\_\_ Input IN5 is qualified by timer TK; timer TK output is KT  
L(1234) =  
A1(1234)=  
A2(1234)=  
V(56) =A\*H\*J \_\_\_\_\_ effectively, V=50NL\*IN6\*79SH  
W(56) =B\*H \_\_\_\_\_ effectively, W=(50H+51NT)\*IN6  
X(56) =J\*KT \_\_\_\_\_ effectively, X=79SH\*IN5(IN5 time qualified by timer TK)  
Y(56) =  
Z(56) =  
A3(1346)=  
A4(2346)=  
TR(1246)=50H+51T+V+W+X \_\_\_\_\_ Programmable tripping conditions  
RC(1246)=  
ER(1246)=  
SEQ(1) =  
ETC(1) =51P \_\_\_\_\_ 51P (and consequently 51T) are externally torque controlled by input IN2=TCP  
ITC(1) =

#### Global settings

DEMUR =Y	CFT =0	TDUR =4	TFT =0	TGR =180
ITT =5	TIME1=15	TIME2=0	AUTO =2	RINGS=3
IN1 =	IN2 =TCP	IN3 =!RE	IN4 =52A	
IN5 =	IN6 =			

Energize input IN3 to disable reclosing; !RE=NOT(RE)

## FIRMWARE IDENTIFICATION

The SEL-251D-1 Relay provides a means of interpreting Firmware Identification Data (FID). The FID string is included near the top of each long event report. The string format is as follows:

FID = [PN] - R[RN] - V[VS] - D[RD] - E[ER],

Where:

[PN] = Product Name (e.g., SEL-251D-1)

[RN] = Revision Number (e.g., 400)

[VS] = Version Specifications (e.g., 656rp1ggdb)

[RD] = Release Date (e.g., YYMMDD = 930719)

[ER] = Version Specification: EEPROM

For the SEL-251 relay family, version specifications are interpreted as follows:

V[VS] = V[ABCDEFGHIJ]

<u>Option</u>	<u>Specifier</u>	<u>Specifier Meaning</u>	<u>Option Description</u>
A	6	60 Hz	Power System Frequency
B	5	5 amps	Nominal Amps per Phase
C	6	120 volts	Nominal Volts Phase-Phase
D	r	radial	Fault Locator type
E	p	positive	Phase-Sequence of Power System
F	1	standard	Recloser
G	g	ground	Target LEDs
H	g	standard	Ground OC Elements
I	d	delta	Voltage Connection
J	b	extended w/fast operate	Fast Meter Command

EEPROM version specifications are interpreted as follows:

E[ER] = E[Z]

<u>Option</u>	<u>Specifier</u>	<u>Specifier Meaning</u>	<u>Option Description</u>
Z	1, 2	1 stop bit, 2 stop bits	Communications Protocol Stop Bits

Please contact Schweitzer Engineering Laboratories, Inc. for information concerning available versions of the SEL-251D-1 Relay. Version specifications provided above are not intended for ordering purposes but to aid in identification of the software installed in a relay.

## APPLICATIONS TABLE OF CONTENTS

---

Fuse-Saving Schemes . . . . .	5-1
Trip-Saving Scheme . . . . .	5-4
Blocking Schemes for Cold Load Inrush . . . . .	5-6
Disable Ground/Residual Overcurrent Elements . . . . .	5-9
Minimum Response Time for Time-Overcurrent Elements . . . . .	5-12
Underfrequency Load Shedding Input . . . . .	5-13
Undervoltage Load Shedding . . . . .	5-14
Breaker Failure . . . . .	5-15
Residual Current Unbalance Alarm . . . . .	5-17
Block Voltage Regulating Load-Tap-Changer Operation . . . . .	5-17
Extra Alarm Output Contact . . . . .	5-17
Back Up Feeder Relays with a Bus Relay . . . . .	5-18
Feeder Relay Setting Changes . . . . .	5-19
Bus-Tie Relay Setting Changes . . . . .	5-20
Clock-Driven Setting Group Selection . . . . .	5-20
Demand-Driven Setting Group Selection . . . . .	5-20
System Restoration After Underfrequency Load Shedding . . . . .	5-21

## FIGURES

Figure 5.1: Fuse-Saving Using Ground/Residual Elements . . . . .	5-1
Figure 5.2: Reclosing Cycle for Permanent Fault Beyond Tap Fuse . . . . .	5-2
Figure 5.3: Effect of 52APU and 52ADO Settings on Relay Word Bits 52AT and 52BT . . . . .	5-3
Figure 5.4: Trip Saving Using Ground/Residual Elements . . . . .	5-5
Figure 5.5: 50C Delayed by TSPU Time . . . . .	5-7
Figure 5.6: Effect of 52APU and 52ADO Settings on Relay Word Bits 52AT and 52BT . . . . .	5-8
Figure 5.7: Minimum Response Time Using Ground/Residual Elements . . . . .	5-13
Figure 5.8: Input IN5 Qualified by Time TKPU . . . . .	5-14
Figure 5.9: Element 27 Qualified by Time TKPU . . . . .	5-14
Figure 5.10: Underfrequency or Undervoltage Trip Condition Time Duration Limit . . . . .	5-16
Figure 5.11: Distribution Feeder Relay Backup Scheme . . . . .	5-19
Figure 5.12: Main/Auxiliary Bus with Bus-Tie Circuit Breaker . . . . .	5-20
Figure 5.13: Underfrequency Load Shedding and Reclose Initiate Supervision . . . . .	5-22
Figure 5.14: Timing for Reclose Initiation . . . . .	5-23



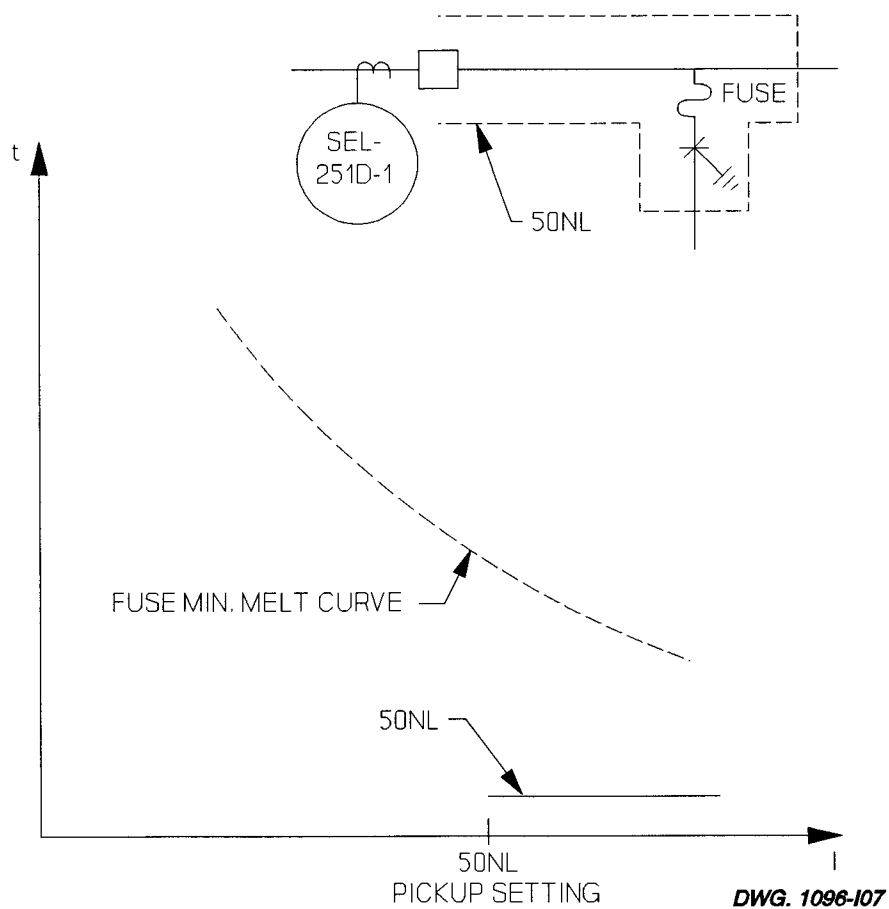


# APPLICATIONS

This section is included as a tool for applying the SEL-251D-1 Relay. The information does not represent suggested settings or standards. Please refer to Section 2: SPECIFICATIONS and Section 3: COMMUNICATIONS to be sure the settings you choose result in relay performance appropriate to your application.

## FUSE-SAVING SCHEMES

In a fuse-saving scheme, the SEL-251D-1 Relay should trip instantaneously for faults on the load side of tap fuses near the substation, attempting to save the fuse if the fault is transient. If the fault is permanent, the fuse will eventually operate on a subsequent shot where relay tripping is delayed. The 50NL ground/residual instantaneous overcurrent element in Figure 5.1 is incorporated in fuse-saving schemes in the following examples.



**Figure 5.1: Fuse Saving Using Ground/Residual Elements**

At least two fuse-saving scheme implementations are possible. One scheme uses the **79SH** Relay Word bit while the other scheme uses the **52AT** Relay Word bit. In the following examples, the goal is to enable element **50NL** for the first one or two shots and disable it for the remaining shots. With **50NL** disabled, the tap fuses operate if the fault is permanent. More information about these two schemes appears below.

**Fuse-Saving Scheme Using the 79SH Bit**

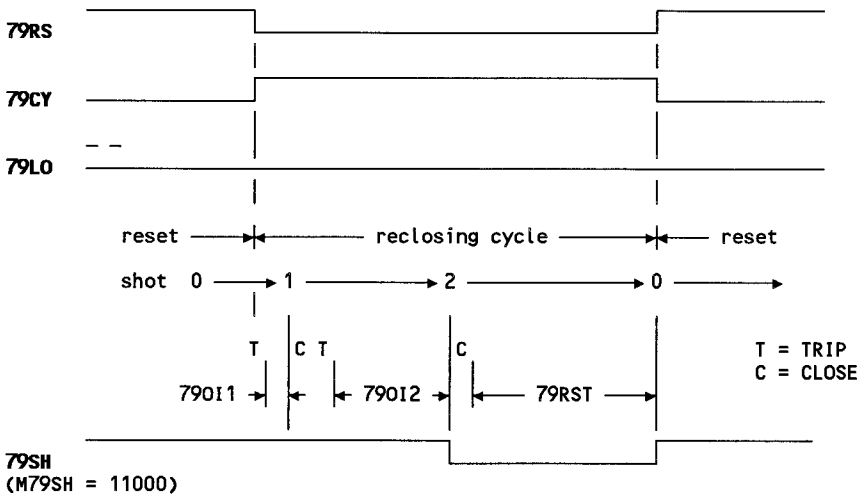
The **79SH** bit asserts (**79SH** = 1) for selected reclosing relay shot counter states (shot = 0, 1, 2, 3, or 4). **79SH** is controlled by the M79SH setting. To assert **79SH** for shot = 0 and shot = 1, M79SH is set as:

$$M79SH = 11000$$

The digits of the M79SH setting (from left to right) are for shots 0 through 4. For a reclosing scheme with only three shots (three automatic reclosures) only the first four digits of the M79SH setting are pertinent (shots 0 through 3). The shot counter increments when the reclosing relay issues an automatic reclosure (CLOSE output contact assertion). Shot = 0 when the circuit breaker is closed and the reclosing relay is reset.

With the M79SH setting shown above, **79SH** remains set from the end of the preceding reset interval (79RST), until the relay issues the second close (shot=2).

**Relay Word Bits**



**Figure 5.2: Reclosing Cycle for Permanent Fault Beyond Tap Fuse**

If element **50NL** is supervised by **79SH**, then **50NL** is enabled for shot = 0 and shot = 1 only.

Using SELOGIC™ Control Equations:

$$B(12) = 50NL$$

$$\begin{aligned}
 E(34) &= 79SH \\
 V(56) &= B * E \\
 TR(1246) &= V + \dots \quad (\text{TR is the programmable trip condition})
 \end{aligned}$$

effectively,  $TR(1246) = 50NL * 79SH + \dots$

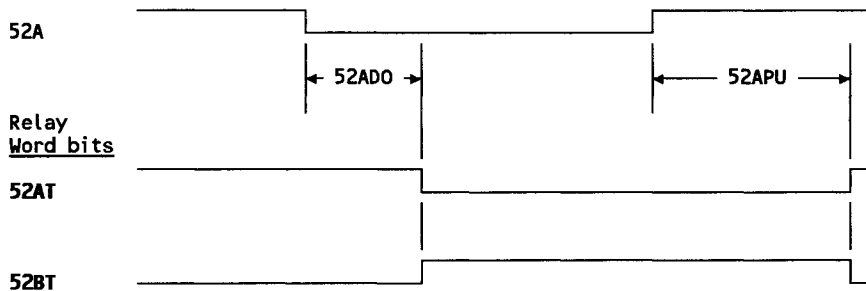
close TRIP output contacts =  $TR + \dots$

i.e., **50NL** is enabled for tripping for shot = 0 and shot = 1 only. If the reclosing relay is reset (shot = 0) and a permanent ground fault occurs beyond the tap fuse in Figure 5.1 (ground fault  $3I_0$  current > **50NL**), the **50NL** element trips the feeder circuit breaker twice. Thus, the tap fuse is "saved" during initial trip (shot = 0) and the subsequent trip after the first reclosure (shot = 1). For the second reclosure (shot = 2), **50NL** is not enabled for tripping (shot = 2) and the tap fuse clears the permanent fault. Figure 5.2 details this reclosing cycle.

If the ground fault was transient, the **50NL** element would have tripped the circuit breaker the first time (shot = 0), extinguishing the fault, and the tap fuse would have been saved.

### Fuse-Saving Scheme using the 52AT Bit

The **52APU** and **52ADO** settings affect Relay Word bits **52AT** and **52BT** as follows:



**Figure 5.3: Effect of 52APU and 52ADO Settings on Relay Word Bits 52AT and 52BT**

Note that the **52BT** bit is the inverse of the **52AT** bit. The discussion involves only the **52AT** bit.

If **50NL** is supervised by **52AT**, **50NL** continues to be disabled for **52APU** time after circuit breaker closure. **52A** asserts when the circuit breaker closes.

Using SELOGIC Control Equations:

$$\begin{aligned}
 B(12) &= 50NL \\
 E(34) &= 52AT \\
 V(56) &= B * E \\
 TR(1246) &= V + \dots \quad (\text{TR is the programmable trip condition})
 \end{aligned}$$

effectively,  $TR(1246) = 50NL * 52AT + \dots$

close TRIP output contacts = TR + ...

If the circuit breaker has been closed longer than 52APU time before a fault occurs, **52AT** = 1 and **50NL** is enabled for tripping. If a permanent ground fault occurs beyond the tap fuse in Figure 5.1 (ground fault  $3I_0$  current > 50NL), the **50NL** element trips the feeder circuit breaker. The circuit breaker opens. The reclosing relay closes the circuit breaker after the first open interval time expires.

**50NL** is disabled for time period 52APU after the circuit breaker closes (**52AT** = 0). The 52APU setting should be long enough to allow the tap fuse to clear the fault. Time period 52ADO is set to zero, or at least shorter than any reclosing relay open interval time.

A fuse-saving scheme using the **52AT** bit makes only one attempt to save the fuse at the first reclosing cycle trip.

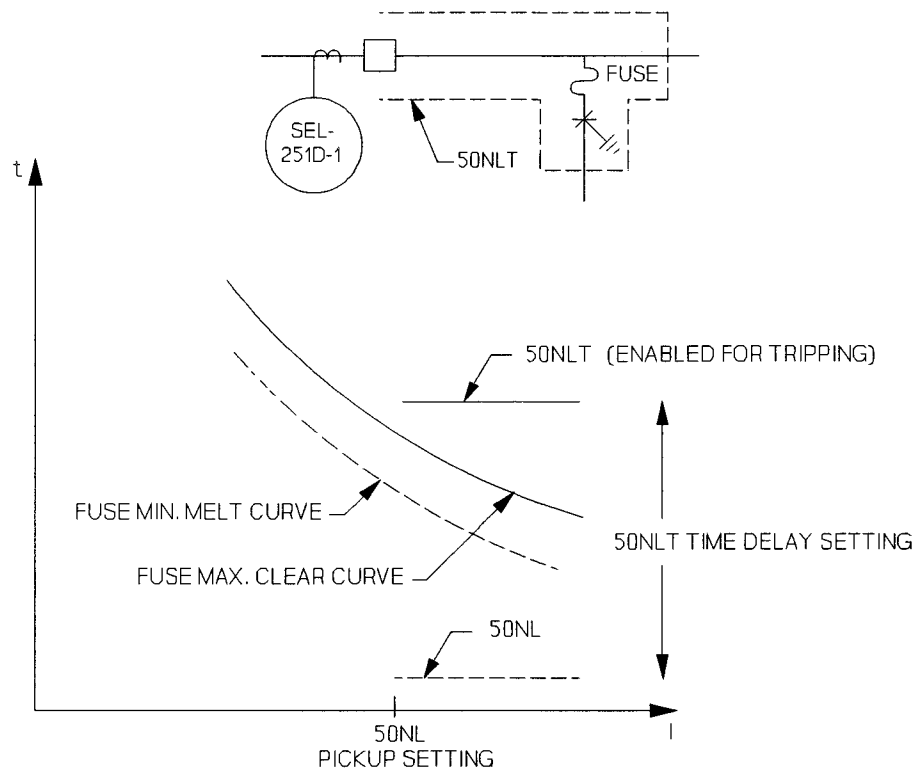
## TRIP-SAVING SCHEME

Trip saving is the opposite of fuse saving. In a trip-saving scheme, the SEL-251D-1 Relay definite-time overcurrent elements have total coordination with tap fuses near the substation. No attempt is made to save the fuse in a fault situation. For a fault to the load side of a tap fuse, the fuse will clear the fault and the SEL-251D-1 Relay will not operate at all. A ground coordination example follows.

Using SELOGIC Control Equations:

$TR(1246) = 50NLT + \dots$  (TR is the programmable trip condition)

close TRIP output contacts = TR + ...



DWG. 1096-108

**Figure 5.4: Trip Saving Using Ground/Residual Elements**

The benefits of trip-saving schemes are:

- The substation circuit breaker does not trip for faults beyond other protective devices (assuming proper coordination); faults are isolated locally, minimizing the number of customers affected by the outage.
- Damage to underground cable and other line equipment is minimized by not reclosing into faults beyond other protective devices (the substation circuit breaker doesn't trip in the first place).
- Other distribution circuits fed from the same substation transformer bank see fewer voltage distortions due to magnetizing inrush or fault current upon reclosure. Fewer trips means fewer consequent reclosures, resulting in fewer voltage distortions to other distribution circuits.

Utilities have written papers about converting from fuse to trip saving on many distribution feeder protection schemes:

"Distribution Overcurrent Protection Philosophy Used at Duke Power Company," R.D. Melchior, B.W. Jackson, Georgia Tech Relay Conference, Atlanta, Georgia, April 29 - May 1, 1987.

"Relaying Changes That Will Reduce Blinks," Neil G. Engelman, P.E., Lincoln Electric System, Lincoln, Nebraska, 33rd Annual American Public Power Association Engineering and Operations Workshop, Washington, D.C., March 15, 1989.

"Relaying Changes Improve Distribution Power Quality," Neil G. Engelman, P.E., Lincoln Electric System, Lincoln, Nebraska, *Transmission & Distribution*, May 1990, pp. 72-76.

In these papers, trip-saving implementations required extra timers for the instantaneous relays to realize definite-time overcurrent elements. Definite-time overcurrent elements are already available in the SEL-251D-1 Relay, eliminating the need for external timers.

## BLOCKING SCHEMES FOR COLD LOAD INRUSH

Overcurrent elements with low pickup and low time delay settings can operate unintentionally on cold load inrush. These overcurrent elements need to be blocked from initiating tripping for a time period after circuit breaker closure if the potential for cold load inrush current exists.

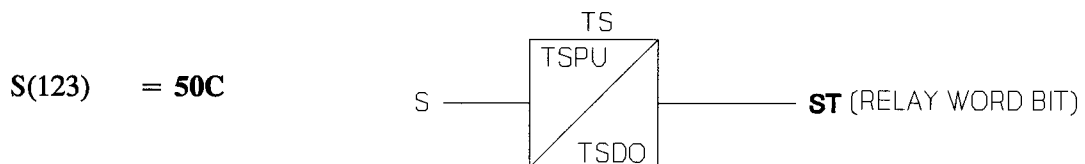
Two overcurrent element blocking scheme implementations are possible. One scheme uses the **50C** Relay Word bit; the other uses the **52AT** Relay Word bit.

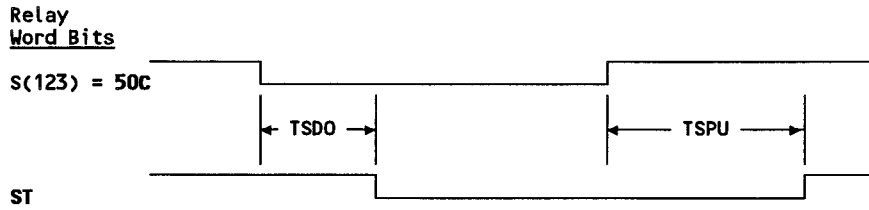
### Blocking Scheme for Cold Load Inrush Using the 50C Bit

**50C** is a phase instantaneous overcurrent element that is not used in the reclosing relay reset inhibit function. Thus it can be set below load levels for a blocking scheme for cold load inrush. **50C** can assert with the presence of load current or deassert in its absence. With this setting, **50C** indicates whether the circuit breaker is closed or open. This scheme is not **52A** dependent. To block an overcurrent element for cold load inrush for a time period after circuit breaker closure, supervise the element with a time delayed pickup **50C** condition.

If **50C** is used in this blocking scheme, it cannot be used in the internal torque control settings. The **50C** pickup setting would be too low.

Using SELOGIC Control Equations:





**Figure 5.5: 50C Delayed by TSPU Time**

If **50L** is supervised by **ST**, **50L** continues to be disabled for time period **TSPU** after the circuit breaker closes and load is picked up. Set **TSPU** slightly greater than the potential cold load inrush time.

Continuing with SELOGIC Control Equations:

$$\begin{aligned}
 \mathbf{B(12)} &= \mathbf{50L} \\
 \mathbf{E(34)} &= \mathbf{ST} && \text{(time delayed 50C)} \\
 \mathbf{V(56)} &= \mathbf{B * E} \\
 \mathbf{TR(1246)} &= \mathbf{V + \dots} && \text{(TR is the programmable trip condition)}
 \end{aligned}$$

$$\text{effectively, } \mathbf{TR(1246)} = \mathbf{50L * ST + \dots}$$

$$\text{close TRIP output contacts} = \mathbf{TR + \dots}$$

If the **TSDO** setting exceeds the longest reclosing relay open interval time setting (**79OI1**, **79OI2**, etc.), **ST** will not drop out during the reclose cycle. Thus, **50L** remains enabled throughout the cycle. **ST** drops out when **TSDO** expires after the recloser goes to lockout (the circuit breaker is open and **50C** = 0). This may be desirable since typical open interval times are not long enough to warrant concern about cold load inrush. Thus, **50L** is disabled for **TSPU** time only after the circuit breaker closes from the lockout state.

To disable **50L** only after the circuit breaker closes from the lockout state, make the following settings.

Using SELOGIC Control Equations:

$$\begin{aligned}
 \mathbf{S(123)} &= \mathbf{50C} \\
 \mathbf{B(12)} &= \mathbf{50L} \\
 \mathbf{E(34)} &= \mathbf{79RS + 79CY + ST} \\
 \mathbf{V(56)} &= \mathbf{B * E} \\
 \mathbf{TR(1246)} &= \mathbf{V + \dots} && \text{(TR is the programmable trip condition)}
 \end{aligned}$$

$$\text{effectively, } \mathbf{TR(1246)} = \mathbf{50L * (79RS + 79CY + ST) + \dots}$$

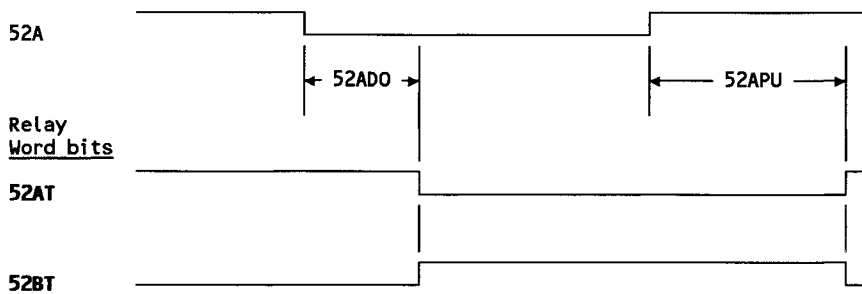
$$\text{close TRIP output contacts} = \mathbf{TR + \dots}$$

**79RS = 79CY = 0** when the relay is in the lockout state. **79RS + 79CY = 1** when the relay is not in the lockout state. Thus, **ST** effectively supervises **50L** only when the relay is in the lockout state. **TSDO** can be set to any value. **50L** is enabled while the reclosing relay is cycling. The **79RST** setting should be greater than the **TSPU** setting.

If setting **50C** is greater than minimum load levels, **50L** is disabled from initiating tripping during minimum load times. If a fault occurred during minimum load times, **50L** would be delayed from operating for the fault for **TSPU** time.

### **Blocking Scheme for Cold Load Inrush Using the 52AT Bit**

The **52APU** and **52ADO** settings affect Relay Word bits **52AT** and **52BT** as follows:



**Figure 5.6: Effect of 52APU and 52ADO Settings on Relay Word Bits 52AT and 52BT**

Note that **52BT** is the inverse of **52AT**. This discussion involves only **52AT**.

If **52AT** supervises **50L**, **50L** continues to be disabled for **52APU** time after circuit breaker closure. Set **52APU** slightly greater than the potential cold load inrush time.

Using SELOGIC Control Equations:

$$\begin{aligned}
 \mathbf{B(12)} &= \mathbf{50L} \\
 \mathbf{E(34)} &= \mathbf{52AT} \\
 \mathbf{V(56)} &= \mathbf{B * E} \\
 \mathbf{TR(1246)} &= \mathbf{V + \dots} \quad (\text{TR is the programmable trip condition})
 \end{aligned}$$

$$\text{effectively, } \mathbf{TR(1246)} = \mathbf{50L * 52AT + \dots}$$

$$\text{close TRIP output contacts} = \mathbf{TR} + \dots$$

If setting **52ADO** exceeds all reclosing relay open interval time settings (**79OI1**, **79OI2**, etc.), **52AT** will not drop out during the reclose cycle, leaving **50L** enabled throughout the reclose cycle. **52AT** drops out when **52ADO** time expires after the recloser goes to lockout (the circuit breaker is open and **52A = 0**). This may be desirable since open interval times are



not long enough to warrant concern about cold load inrush. Thus, **50L** continues to be disabled for **52APU** time only after the circuit breaker closes from the lockout state.

To disable **50L** only after the circuit breaker closes from the lockout state, make the following settings.

Using SELOGIC Control Equations:

$$\begin{aligned} \mathbf{B(12)} &= \mathbf{50L} \\ \mathbf{E(34)} &= \mathbf{79RS+79CY+52AT} \\ \mathbf{V(56)} &= \mathbf{B*E} \\ \mathbf{TR(1246)} &= \mathbf{V+...} \quad (\text{TR is the programmable trip condition}) \end{aligned}$$

$$\text{effectively, } \mathbf{TR(1246)} = \mathbf{50L*(79RS+79CY+52AT)+...}$$

$$\text{close TRIP output contacts} = \mathbf{TR} + \dots$$

**79RS** = **79CY** = 0 when the relay is in the lockout state. **79RS** + **79CY** = 1 when the relay is not in the lockout state. Thus, **52AT** effectively supervises **50L** only when the relay is in the lockout state. **52ADO** can be set to any value. **50L** is enabled while the reclosing relay is cycling. The **79RST** setting should be greater than the **52APU** setting.

## DISABLE GROUND/RESIDUAL OVERCURRENT ELEMENTS

Ground relays are often temporarily disabled during distribution circuit paralleling operations. This is done to avoid ground relay trips resulting from residual current unbalance. This unbalance results from line switches not closing or opening all phases in unison when making or breaking parallel, respectively. Ground/residual overcurrent elements in the SEL-251D-1 Relay can be disabled by inputs functioning as permissive trip, block trip, or torque control inputs. You can apply the principles in the following examples to other elements.

### Disable Ground/Residual Overcurrent Elements with Permissive Trip Input

When a permissive trip input is energized, selected overcurrent elements are enabled for tripping. When a permissive trip input is de-energized, selected overcurrent elements are disabled for tripping.

Inputs **IN5** and **IN6** are available in the Relay Word and can be effectively used as permissive trip inputs.

Using SELOGIC Control Equations:

$A(12) = 51NT$  (ground/residual time-overcurrent element)  
 $F(34) = IN5$  (input IN5 to function as a permissive trip input)  
 $V(56) = A * F$   
 $TR(1246) = V + \dots$  (TR is the programmable trip condition)

effectively,  $TR(1246) = 51NT * IN5 + \dots$

close TRIP output contacts = TR + ...

Some applications may require that the permissive trip input supervise a low-set ground residual instantaneous overcurrent element. In the following example, 79SH also supervises the low-set ground/residual instantaneous overcurrent element 50NL in a fuse-saving scheme.

Using SELOGIC Control Equations:

$A(12) = 51NT$  (ground/residual time-overcurrent element)  
 $B(12) = 50NL$  (low-set ground residual instantaneous overcurrent element)  
 $E(34) = 79SH$   
 $F(34) = IN5$  (input IN5 will function as a permissive trip input)  
 $V(56) = A * F$   
 $W(56) = B * E * F$   
 $TR(1246) = V + W + \dots$  (TR is the programmable trip condition)

effectively,  $TR(1246) = (51NT * IN5) + (50NL * 79SH * IN5) + \dots$   
which reduces to:  $TR(1246) = [51NT + (50NL * 79SH)] * IN5 + \dots$

close TRIP output contacts = TR + ...

### Disable Ground/Residual Overcurrent Elements with Block Trip Input

When a block trip input is energized, selected overcurrent elements are disabled for tripping. When a block trip input is de-energized, selected overcurrent elements are enabled for tripping. This function is the opposite of a permissive trip input.

Inputs IN5 and IN6 are available in the Relay Word and can be effectively used as block trip inputs.

Using SELOGIC Control Equations:

$A(12) = 51NT$  (ground/residual time-overcurrent element)  
 $L(1234) = IN5$  (input IN5 to function as a block trip input)  
 $V(56) = A * !L$  ( $!L = NOT(L) = NOT(IN5)$ )  
 $TR(1246) = V + \dots$  (TR is the programmable trip condition)

effectively,  $TR(1246) = 51NT * NOT(IN5) + \dots$

close TRIP output contacts = TR + ...

Some applications may require that the block trip input supervise a low-set ground residual instantaneous overcurrent element. In the following example, **52AT** also supervises the low-set ground/residual instantaneous overcurrent element **50NL** in a fuse-saving scheme.

Using SELOGIC Control Equations:

**A(12)** = **51NT** (ground/residual time-overcurrent element)  
**B(12)** = **50NL** (low-set ground residual instantaneous overcurrent element)  
**E(34)** = **52AT**  
**L(1234)** = **IN5** (input IN5 will function as a block trip input)  
**V(56)** = **A\*!L** (!L=NOT(L) = NOT(IN5))  
**W(56)** = **B\*E\*!L**  
**TR(1246)** = **V+W+...** (TR is the programmable trip condition)

effectively, **TR(1246)** = **[51NT\*NOT(IN5)]+[50NL\*52AT\*NOT(IN5)]+...**  
which reduces to: **TR(1246)** = **[51NT+(50NL\*52AT)]\*NOT(IN5)+...**

close TRIP output contacts = TR + ...

If the control wiring into input IN5 is accidentally open circuited (IN5 is de-energized; IN5=0), elements supervised by IN5 are still enabled, enhancing dependability.

### Disable Ground/Residual Overcurrent Elements with Torque Control Input

When a torque control input is energized, selected overcurrent elements are enabled for operation.

When a torque control input is de-energized, selected overcurrent elements are disabled from operation. In such a state, selected instantaneous overcurrent elements do not pick up if current exceeds their pickup settings. Selected definite-time overcurrent and time-overcurrent elements do not start timing when current exceeds pickup settings.

For example, assign input IN4 to function as the ground/residual overcurrent element torque control input. Using the SET G command (global settings):

**IN4** = **TCG** (external torque control input  
for ground/residual elements)

Then externally torque control the ground/residual time-overcurrent element **51NT**.

Using SELOGIC Control Equations:

**TR(1246)** = **51NT+...** (TR is the programmable trip condition)  
**ETC(1)** = **51NP** (choose elements to be externally torque controlled)

close TRIP output contacts = TR + ...

Setting ETC(1) lists overcurrent pickups to be externally torque controlled. Element **51NP** is the pickup for **51NT**. If **51NP** is torque controlled, **51NT** is also torque controlled. This is how the relay achieves torque controlling for time-overcurrent and definite-time overcurrent elements via pickups.

In this example, energizing input IN4 enables the **51NT** element; de-energizing input IN4 disables the **51NT** element.

If  $IN4 = !TCG$ , the opposite sense is on the input. De-energizing input IN4 enables the **51NT** element; energizing input IN4 disables the **51NT** element.

Implementation of this scheme using the external torque control function is much more efficient than the previous two examples. You can use the SELOGIC Control Equations variables saved to implement other schemes as needed.

## MINIMUM RESPONSE TIME FOR TIME-OVERCURRENT ELEMENTS

For time-overcurrent element coordination problems at higher fault current levels, you can incorporate a minimum response time into the time-overcurrent element. Such a time-overcurrent element cannot operate until a set minimum time passes. A ground/residual time-overcurrent element example appears below.

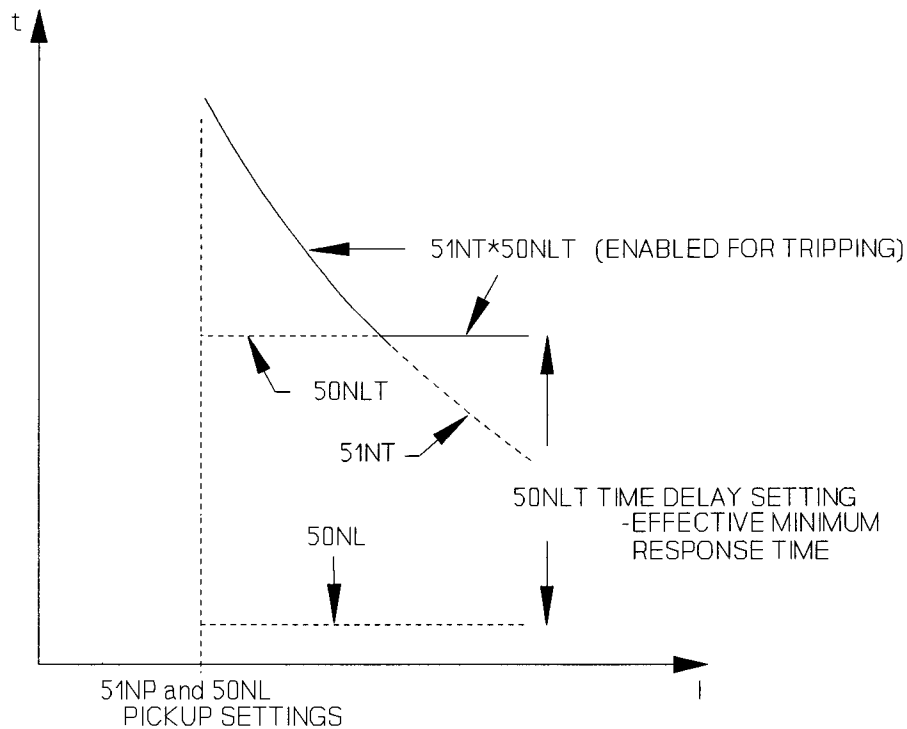
To implement this scheme, set **51NT** and **50NLT** with the same magnitude pickup setting ( $51NP = 50NL$ ). Set the **50NLT** setting with the desired minimum response time.

Using SELOGIC Control Equations:

<b>A(12)</b>	= <b>51NT</b>	(ground/residual time-overcurrent element)
<b>B(12)</b>	= <b>50NLT</b>	(ground residual definite-time overcurrent element)
<b>V(56)</b>	= <b>A*B</b>	
<b>TR(1246)</b>	= <b>V+...</b>	(TR is the programmable trip condition)

effectively,  $TR(1246) = 51NT*50NLT + \dots$

close TRIP output contacts = TR + ...



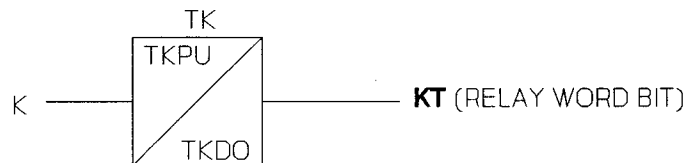
**Figure 5.7: Minimum Response Time Using Ground/Residual Elements**

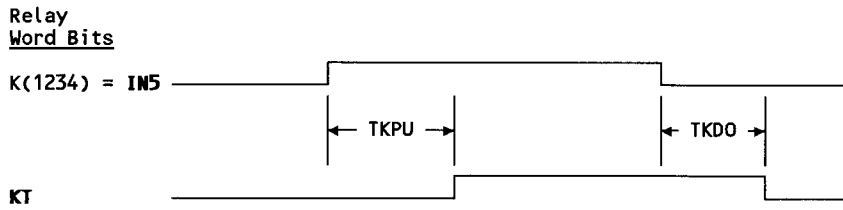
## UNDERFREQUENCY LOAD SHEDDING INPUT

Relay Word inputs IN5 and IN6 can be used as time-qualified underfrequency load shedding inputs. The output of an underfrequency relay is wired into IN5 or IN6.

Using SELoGIC Control Equations:

$$K(1234) = IN5$$





**Figure 5.8: Input IN5 Qualified by Time TKPU**

Time TKPU qualifies the underfrequency input condition.

Continuing with SELOGIC Control Equations:

$$TR(1246) = KT + \dots \quad (\text{TR is the programmable trip condition})$$

$$\text{close TRIP output contacts} = TR + \dots$$

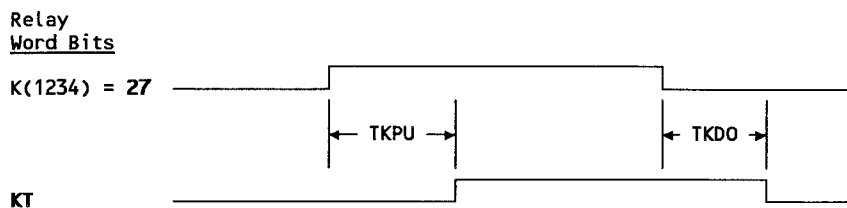
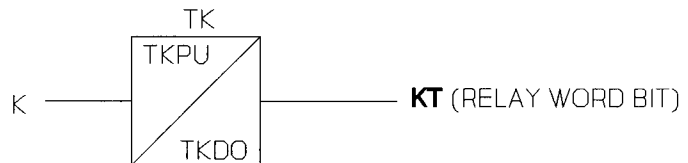
Relays on different feeders can have different TKPU time delay pickup settings so certain feeders are tripped before others during a system underfrequency condition.

## UNDERVOLTAGE LOAD SHEDDING

An undervoltage load shedding condition is possible by time qualifying the **27** Relay Word bit.

Using SELOGIC Control Equations:

$$K(1234) = 27$$



**Figure 5.9: Element 27 Qualified by Time TKPU**

The TKPU time qualifies the undervoltage condition.

Continuing with SELOGIC Control Equations:

$$TR(1246) = \mathbf{KT} + \dots \quad (\text{TR is the programmable trip condition})$$

$$\text{close TRIP output contacts} = \text{TR} + \dots$$

A system undervoltage condition is a three-phase phenomenon, so the **27** element should be set three-phase sensitive (setting **27C** = 3). Set high- and low-set limits for **27** (**27H** and **27L**), according to system conditions.

## BREAKER FAILURE

Use the **TF** bit in the Relay Word to create a breaker failure scheme.

Using SELOGIC Control Equations:

$$A1(1234) = \mathbf{TF}$$

Output contact A1 operates as a breaker failure output. Breaker failure applications need the following setting relationship.

$$\text{TFT (Trip Failure Time)} > \text{TDUR (Trip Duration Time)}$$

### Breaker Failure Implementation Notes

The "close TRIP output contacts" condition drives the trip failure timer. This condition ends if all trip conditions vanish and all overcurrent element pickups in Relay Word row R1 drop out. For more information, see Figure 2.22.

Even if a circuit breaker trips successfully and all overcurrent element pickups in Relay Word row R1 drop out, a trip condition can still be present.

For example,  $TR(1246) = \mathbf{KT} + \dots$ , from the previous underfrequency or undervoltage load shedding applications.

$$\text{close TRIP output contacts} = TR(1246) + \dots$$

In this example, a false breaker failure operation can occur if **KT** remains asserted long enough for the trip failure timer to expire. This problem can be overcome if trip condition **KT** is qualified by the presence of load current or limited in duration.

### **Qualify Trip Condition with Presence of Load Current**

Phase instantaneous overcurrent element **50C** is not used in the reclosing relay reset inhibit function and can be set below load levels. **50C** can assert with the presence of load current or deassert in its absence. With this low setting **50C** can indicate whether the circuit breaker is closed or open. There is no **52A** dependence.

Using SELOGIC Control Equations to qualify **KT**:

$A(12) = 50C$   
 $K(1234) = IN5 \text{ or } 27$  (underfrequency or undervoltage application)  
 $V(56) = A*KT$   
 $TR(1246) = V + \dots$  (TR is the programmable trip condition)

close TRIP output contacts = TR + ...

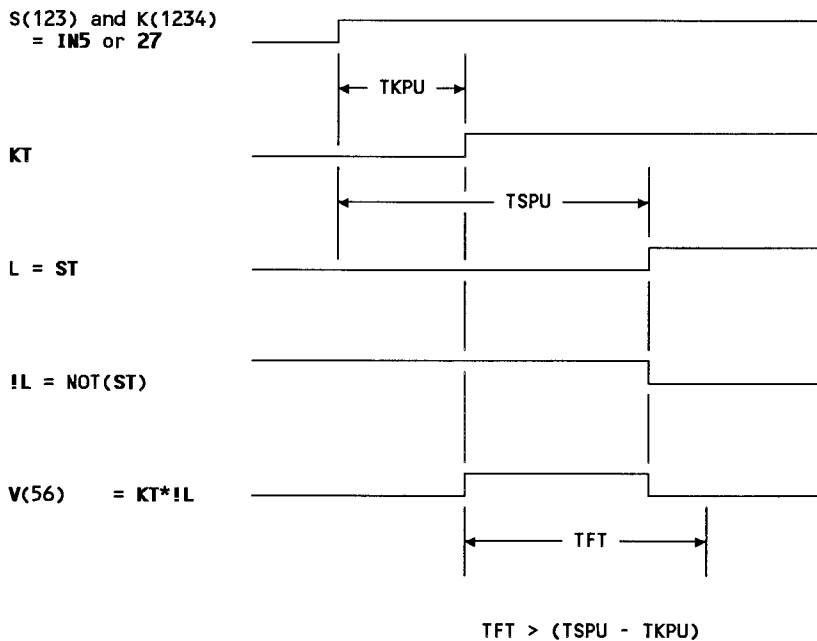
### Limit Trip Condition Time Duration

Limiting the **KT** trip condition duration to a time shorter than TFT prevents false breaker failure operation.

Using SELOGIC Control Equations to effectively limit the duration of **KT**:

$S(123) = IN5 \text{ or } 27$  (underfrequency or undervoltage application)  
 $L(1234) = ST$   
 $K(1234) = IN5 \text{ or } 27$  (underfrequency or undervoltage application)  
 $V(56) = KT*!L$  (!L limits the duration of **KT**)  
 $TR(1246) = V + \dots$  (TR is the programmable trip condition)

close TRIP output contacts = TR + ...



**Figure 5.10: Underfrequency or Undervoltage Trip Condition Time Duration Limit**



## RESIDUAL CURRENT UNBALANCE ALARM

The **NDEM** bit asserts when current exceeds ground/residual demand threshold setting **NDEM**.

Using SELOGIC Control Equations:

$$A2(1234) = \mathbf{NDEM}$$

Output contact **A2** asserts for residual current unbalance. It can also warn of impending ground/residual overcurrent relay pickup due to residual current unbalance.

All demand ammeters use the same time constant (**DATC** = settable from 5 to 60 minutes).

## BLOCK VOLTAGE REGULATING LOAD-TAP-CHANGER OPERATION

Load-tap-changers should not operate when a reclosing cycle is in progress because fault current should not pass through a tap-changer in motion. Also, if the voltage input to the load-tap-changer is on the load side of the feeder circuit breaker, the load-tap-changer will see zero voltage during the reclosing relay open intervals and will erroneously start to move toward the highest tap possible in an attempt to raise the voltage.

The **79CY** bit asserts when the reclosing relay is in the reclose cycle state.

Using SELOGIC Control Equations:

$$A3(1346) = \mathbf{79CY} \quad (\text{Output contact A3 should be configured as a "b" contact})$$

Another implementation:

The **79RS** bit or **79LO** bit are asserted when the reclosing relay is in the reset state or lockout state (the reclosing relay is not in the reclose cycle state).

Using SELOGIC Control Equations:

$$A3(1346) = \mathbf{79RS+79LO} \quad (\text{Output contact A3 should be configured as an "a" contact})$$

For either implementation the **A3** output contact is wired to the load-tap-changer control. The **A3** output contact opens when the reclosing relay is in the reclosing cycle. This prevents load-tap-changer operation.

Depending on the nature of the load-tap-changer control circuit, this application may be best implemented by having an the **SEL-251D-1** Relay output contact connect to an interposing relay. The interposing relay can then connect to the load-tap-changer control circuit.

## EXTRA ALARM OUTPUT CONTACT

The A4 output contact can function as an extra ALARM output contact, depending on the placement of jumper JMP3. With jumper JMP3 in the A4 position, the A4 output contact operates per setting A4(2346). With jumper JMP3 in the ALARM position, the A4 output contact operates with the ALARM output contact.

All the output contacts can be configured as "a" or "b" contacts with soldered wire jumpers JMP4 through JMP11 (each jumper has positions A and B). ALARM output contacts are usually "b" contacts, so soldered wire jumper JMP5 (for A4 output contact) should be in the B position for the A4 output contact to operate as an extra ALARM output contact.

This extra alarm contact can be used to notify backup protective relays of the primary relay failure condition so that protection adjustments can be made. It can also be used for local annunciation, SCADA input, trip supervision, etc.

## BACKUP FEEDER RELAYS WITH A BUS RELAY

Use one SEL-251CD Relay to backup the SEL-251D-1 Relays installed on individual feeders. The feeder relay ALARM contact can supervise a trip from the bus relay because backup is required only when the feeder relay fails. Because of this supervision, the bus relay TRIP output contacts can be set to operate simultaneously with feeder relay TRIP output contacts, both attempting to trip the feeder circuit breaker.

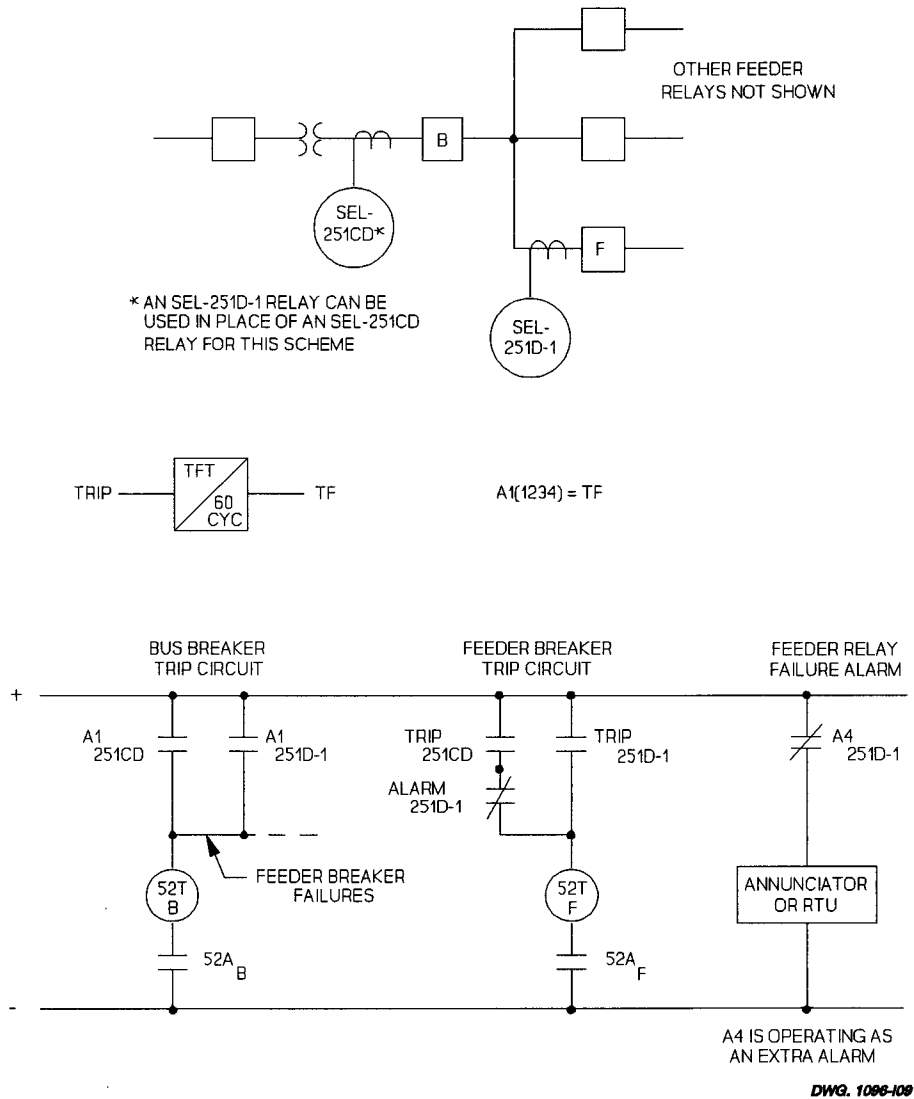
Time delayed trips from the feeder relays (for feeder circuit breaker failures) and the bus relay can trip the bus breaker. These time delayed trips are possible using the trip failure logic available in the SEL-251D-1 and SEL-251CD Relays.

Using SELOGIC Control Equations (for SEL-251D-1 and SEL-251CD Relays):

$$A1(1234) = TF$$

The TFT (trip failure time) settings provide the time delay for the A1 output contacts.

With the SEL-251D-1 Relay ALARM output contact supervising the SEL-251CD Relay TRIP, the SEL-251D-1 Relay A4 output contact can function as an extra ALARM output contact by the placement of jumper JMP3 in the ALARM position. The A4 output contact is made a "b" contact by soldering wire jumper JMP5 in the B position. This output contact can alarm a local annunciator or SCADA RTU for feeder relay failure.



**Figure 5.11: Distribution Feeder Relay Backup Scheme**

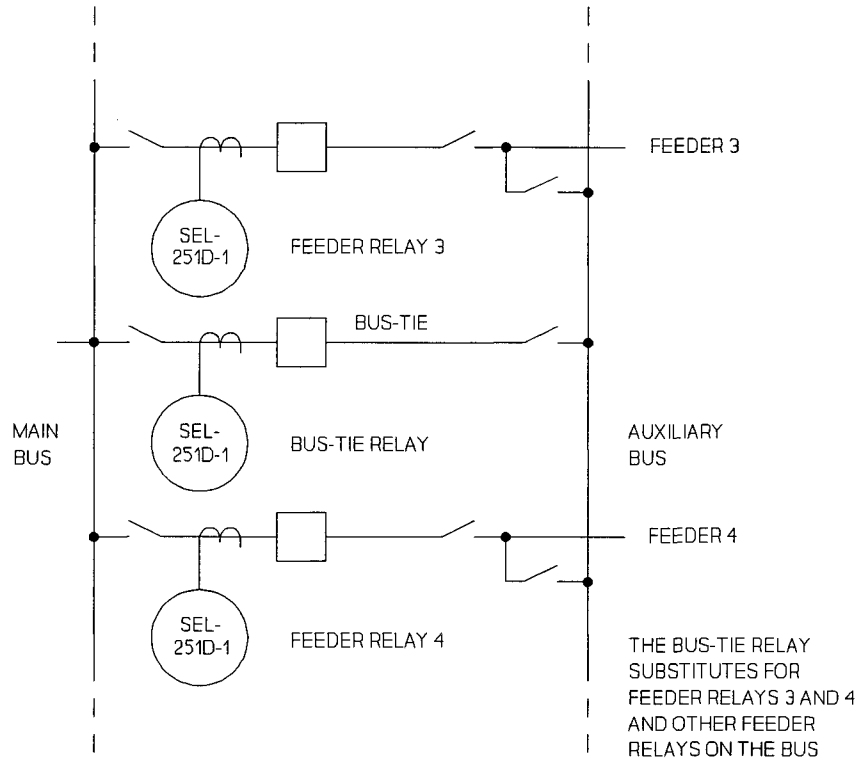
## FEEDER RELAY SETTING CHANGES

When a faulted feeder section is isolated and customers beyond the fault are backfed, the feeder configurations are different. One is shorter with less load, while the other is longer with more load. Save setting groups for different feeder configurations to optimize protection.

You can parallel one feeder with another for breaker maintenance. Program setting groups for normal or parallel operation.

## BUS-TIE RELAY SETTING CHANGES

In stations where bus-tie breakers substitute for feeder breakers during maintenance, the bus-tie breaker relay can have a setting group for each feeder it protects.



DWG. 1096-110

**Figure 5.12: Main/Auxiliary Bus with Bus-Tie Circuit Breaker**

## CLOCK-DRIVEN SETTING GROUP SELECTION

Consider seasonal, weekend/weekday, and daily system changes. Develop optimum settings for various times, and use clock contacts to select appropriate settings.

## DEMAND-DRIVEN SETTING GROUP SELECTION

Trigger a change to less sensitive settings when demand (phase, negative-sequence or ground/residual) encroaches on relay settings, thus avoiding nuisance trips. Set an alarm so problems can be investigated.

## SYSTEM RESTORATION AFTER UNDERFREQUENCY LOAD SHEDDING

After a feeder circuit breaker has been tripped by an underfrequency relay, the reclosing relay in the SEL-251D-1 Relay can reclose the breaker, after system frequency returns to normal. Manual or SCADA closing of the breaker is not necessary. This can be of benefit in remote substations that are not readily accessible by utility personnel or do not have SCADA-type control. This reclosing function is realized in the following example (see Figures 5.13 and 5.14):

IN6 = !52AR                      Circuit Breaker Status (52B contact input)/Reclose Initiate

If input IN6 is de-energized and then energized, circuit breaker status is interpreted to be a breaker in the process of opening (52B<sub>F</sub> contacts assert for opening breakers) and this initiates reclosing.

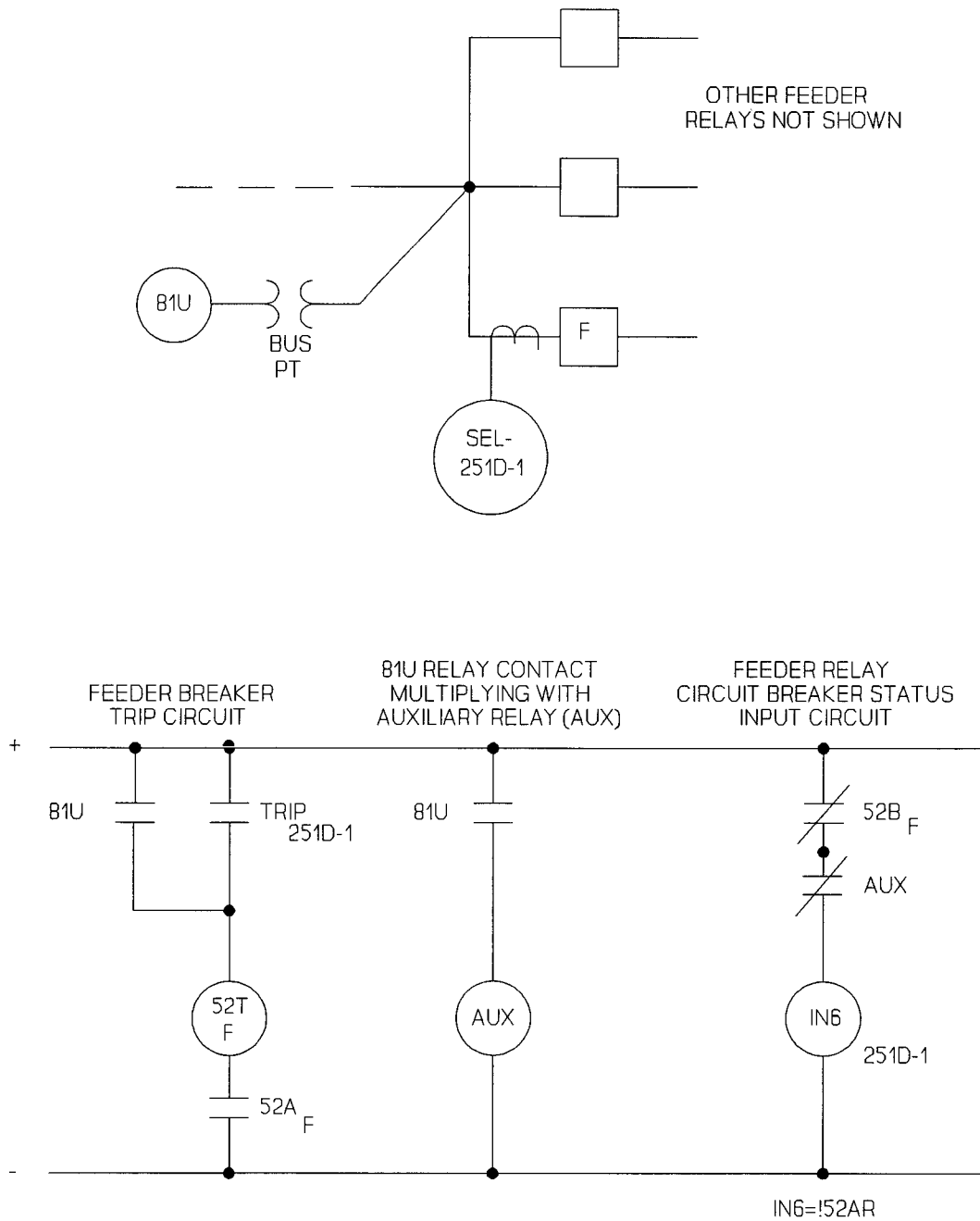
When an underfrequency condition is present, the underfrequency relay contacts (81U) close, tripping the feeder circuit breaker and energizing the auxiliary relay (AUX). In the feeder relay circuit breaker status input circuit, the AUX contact ("b" seal) opens to prevent reclose initiation by the assertion of the 52B<sub>F</sub> contact (continue to keep input IN6 de-energized during the underfrequency condition).

There can be a possible contact race between the 52B<sub>F</sub> and AUX contacts in the feeder relay circuit breaker status input circuit. If the 52B<sub>F</sub> contact closes before the AUX contact opens, input IN6 will be energized and reclosing will be initiated for an underfrequency trip.

To avoid this problem, the circuit breaker status function internal to the relay has a 10-cycle delay to qualify circuit breaker opening, when 52AR or !52AR is assigned to an input. For this application, if the AUX contact opens in less than 10 cycles after the 52B<sub>F</sub> contact closes, the circuit breaker status function deems the circuit breaker still closed and reclosing is not initiated.

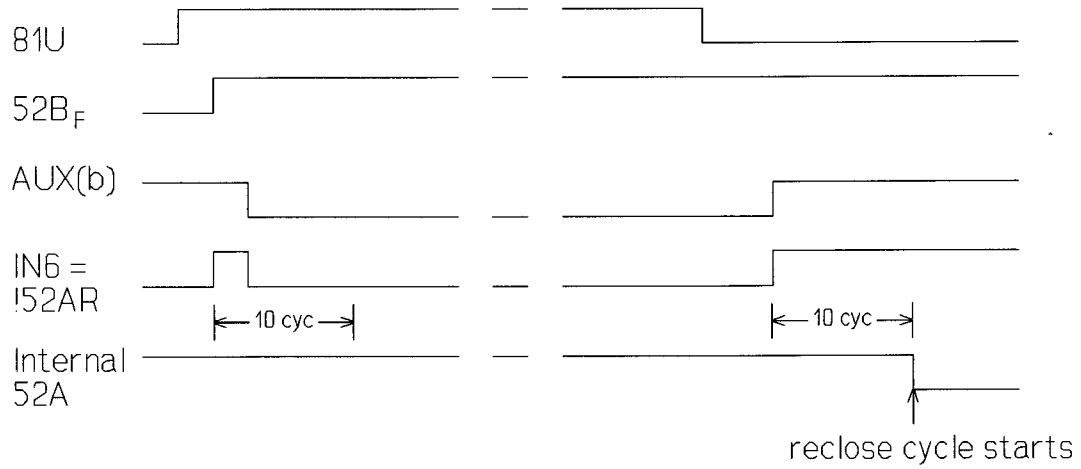
When system frequency returns to normal, the 81U contacts open, de-energizing the AUX relay. The 52B<sub>F</sub> contact is already closed, so the closing of the AUX contact energizes input IN6. After the 10-cycle delay to qualify circuit breaker opening, the circuit breaker is deemed to have opened and reclosing is initiated (the reclosing cycle starts).

In most applications, circuit breaker trips external to the relay (e.g., by control switch or SCADA) must not cause reclose initiation. If input option RE (Reclose Enable) is assigned to an input, the RE input is de-energized to prevent automatic reclosing. Certain control switch contacts can be wired to the RE input to defeat reclosing for control switch trips.



DWG. 1096-111

**Figure 5.13: Underfrequency Load Shedding and Reclose Initiate Supervision**



**Figure 5.14: Timing for Reclose Initiation**





# INSTALLATION TABLE OF CONTENTS

---

Installation . . . . .	6-1
Installation Checkout . . . . .	6-6
SEL Direction and Polarity Check Form . . . . .	6-13

## TABLES

Table 6.1: IRIG-B Pin Definition . . . . .	6-5
--	-----

## FIGURES

Figure 6.1: 9-Pin Connector Pin Number Convention . . . . .	6-4
Figure 6.2: SEL-251D-1 Relay Horizontal Front and Rear Panel Drawings . . . . .	6-8
Figure 6.3: Relay Dimensions, Panel Cutout, and Drill Diagrams . . . . .	6-9
Figure 6.4: Communications and Clock Connections - One Unit at One Location . . . . .	6-10
Figure 6.5: Remote Communications, Local Display, and Clock Connections - Multiple Relay Units at One Location . . . . .	6-10
Figure 6.6: SEL Relay Communications Diagram for Connection to the SEL-DTA . . . . .	6-11
Figure 6.7: SEL-251D-1 Relay Typical AC External Current and Voltage Connections . . . . .	6-11
Figure 6.8: SEL-251D-1 Relay Typical DC External Connections . . . . .	6-12
SEL Direction and Polarity Check Form . . . . .	6-13



# INSTALLATION

---

## INSTALLATION

### Mounting

The relay is designed for mounting by its front vertical flanges in a 19" vertical relay rack. It may also be mounted semi-flush in a switchboard panel. Use four #10 screws for mounting. This section includes front and rear panel drawings.

### Frame Ground Connection

Terminal 46 on the rear panel must be connected to frame ground for safety and performance. These terminals connect directly to the chassis ground of the instrument.

### Power Connections

Terminals 44 and 45 on the rear panel must be connected to a source of control voltage. Control power passes through these terminals to the fuse(s) and a toggle switch, if installed. The power continues through a surge filter and connects to the switching power supply. The control power circuitry is isolated from the frame ground.

### Secondary Circuits

The relay presents a very low burden to the secondary potential and current circuits. It requires three currents from the power system current transformer secondaries.

The four-wire wye potential from potential transformer secondaries is optional. It is used for fault locating, voltage and MW/MVAR metering, and undervoltage torque control.

### Control Circuits

The control inputs are dry. For example, to assert the IN5 input, you must apply control voltage to the IN5 input terminals. Each input is individually isolated, and a terminal pair is brought out for each input. There are no internal connections between control inputs.

Control outputs are dry relay contacts rated for tripping duty. A metal-oxide varistor protects each contact.

## **Communications Circuits**

Connections to the two EIA RS-232-C serial communications ports are made via the two 9-pin connectors labeled Port 1 and Port 2R on the rear panel and Port 2F on the front panel. Pins 5 and 9 connect directly to frame (chassis) ground. See Table 3.1 for pin assignment.

**Warning:** Do not rely upon pins 5 and 9 for safety grounding, since their current-carrying capacity is less than control-power short circuit current and protection levels.

The communications circuits are protected by low-energy, low-voltage MOVs and passive RC filters. You can minimize communications-circuit difficulties by keeping the length of the EIA RS-232-C cables as short as possible. Lengths of twelve feet or less are recommended, and the cable length should never exceed 100 feet. Use shielded communications cable for lengths greater than ten feet. Modems are required for communications over long distances.

Route the communications cables well away from the secondary and control circuits. Do not bundle the communications wiring with secondary or control circuit wiring. If these wires are bundled, switching spikes and surges can cause noise in the communications wiring. This noise may exceed the communications logic thresholds and introduce errors. The IRIG-B clock cable should also be routed away from the control wiring and secondary circuits.

## **Jumper Selection**

Jumpers JMP103, JMP104, and J6 are on the front edge of the main board. They are easily accessed by removing the top cover or front panel. Jumpers JMP3 and soldered wire jumpers JMP4 through JMP11 are toward the back of the main board and are accessed by removing the top cover.

### **EIA RS-232-C Jumpers**

J6 provides EIA RS-232-C baud rate selection. Available baud rates are 300, 600, 1200, 2400, 4800, and 9600. To select a baud rate for a particular port, place the jumper so it connects a pin labeled with the desired port to a pin labeled with the desired baud rate.

**Caution:** Do not select two baud rates for the same port. This can damage the baud rate generator.

### **Password Protection Jumper**

Put JMP103 in place to disable password protection. This feature is useful if passwords are not required or when passwords are forgotten.

## **OPEN/CLOSE Command Enable Jumper**

With jumper JMP104 in place, the OPEN and CLOSE commands are enabled. If you remove jumper JMP104, OPEN and CLOSE command execution results in the message: "Aborted."

## **A4 Output Contact Jumper**

With jumper JMP3 in the A4 position, the A4 output contact operates per setting A4(2346). With jumper JMP3 in the ALARM position, the A4 output contact operates with the ALARM output contact.

## **Output Contact Soldered Wire Jumpers**

All the output contacts can be configured as "a" or "b" contacts with soldered wire jumpers JMP4 through JMP11 (each jumper has positions A and B). The output contact/soldered wire jumper correspondence is as follows:

<u>Output Contact</u>	<u>Jumper</u>
TRIP (terminals 1,2)	JMP11
TRIP (terminals 3,4)	JMP10
CLOSE	JMP9
A1	JMP8
A2	JMP7
A3	JMP6
A4	JMP5
ALARM	JMP4

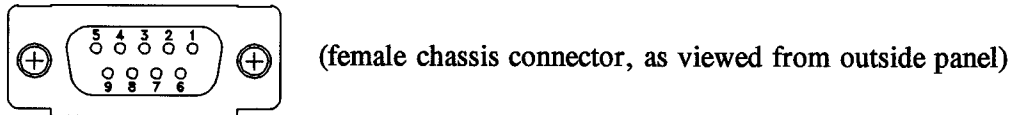
## **Communication Port External Power Jumpers**

DC power is available from Port 1 and Port 2R to power external devices. Jumpers must be selected to route dc power to the rear panel connectors. The internal jumpers are near Port 1 and are labeled as follows: JMP12 = +5 V; JMP13 = +12 V; JMP14 = -12 V. Use caution to ensure the dc current requirement of the external equipment does not exceed the relay power supply specifications. Only route dc power to the rear ports if required for your application.

## **EIA RS-232-C and IRIG-B Installation**

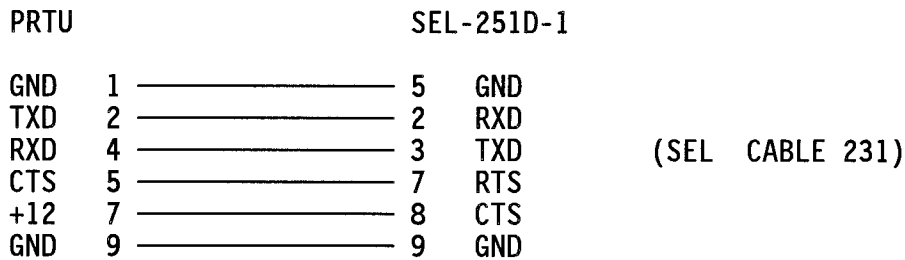
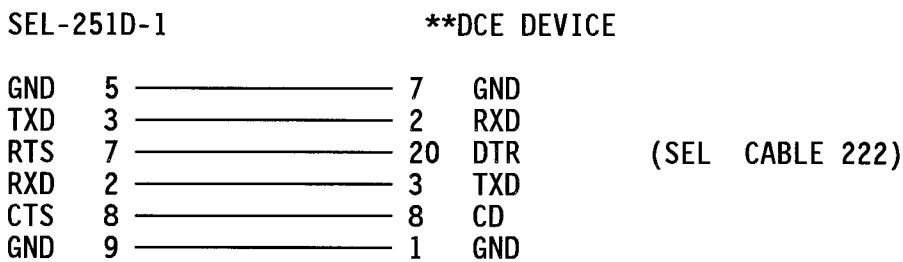
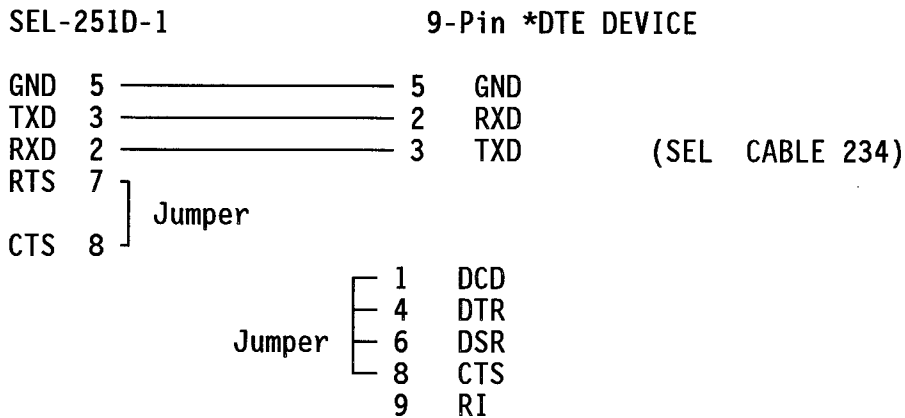
The following information contains specific details regarding communications port pinouts.

A pin definition of the nine-pin port connectors and cabling information for the EIA RS-232-C ports appears in Figure 6.1. The following cable listings show several types of EIA RS-232-C cables. These and other cables are available from SEL. Cable configuration sheets are also available at no charge for a large number of devices. Contact the factory for more information.



**Figure 6.1: 9-Pin Connector Pin Number Convention**

**EIA RS-232-C Cables**



\* DTE = Data Terminal Equipment (Computer, Terminal, Printer, etc.)

\*\* DCE = Data Communication Equipment (Modem, etc.)

## IRIG-B Input Description

The port labeled J201/AUX INPUT receives demodulated IRIG-B input. Pin definitions appear in Table 6.1.

<u>Pin</u>	<u>Name</u>	<u>Description</u>
1	+5	*
2	IRIGIN HI	Positive IRIG-B input.
3	IRIGIN LOW	Negative IRIG-B input.
4	+12	*
6	-12	*
5, 9	GND	Ground for ground wires and shields.

\* Consult the factory before using these power supply outputs

The actual IRIG-B input circuit is a 56 ohm resistor in series with an optocoupler input diode. The input diode has a forward drop of about 1.5 volts. Driver circuits should put approximately 10 mA through the diode when "on."

The IRIG-B serial data format consists of a one second frame containing 100 pulses and divided into fields. The relay decodes the second, minute, hour, and day fields and sets the internal relay clock accordingly.

When IRIG-B data acquisition is activated either manually (with the IRIG command) or automatically, two consecutive frames are taken. The older frame is updated by one second and the two frames are compared. If they do not agree, the relay considers the data erroneous and discards it.

The relay reads the time code automatically about once every five minutes. The relay stops IRIG-B data acquisition ten minutes before midnight on New Year's Eve so the relay clock may implement the year change without interference from the IRIG-B clock. Ten minutes later, the relay restarts IRIG-B data acquisition.

## INSTALLATION CHECKOUT

You may follow the suggestions below or combine them with your normal practice. Never implement recommendations prohibited by the rules of your normal practice. The checkout procedure recommends various settings for ease of testing. These settings may not be applicable to an in service installation.

The following equipment is required for initial checkout:

- Portable terminal or computer with interconnecting cable (connect to Port 2F)
  - Control power to the relay power connections
  - Source of three-phase voltages and at least one current source
  - Ohmmeter or contact opening/closing device
1. Apply control power and make sure the terminal displays the startup message. If not, set `AUTO = 2` with the `SET G` command in Access Level 2. Check the settings with the `ACCESS` and `SHOWSET` commands. Use the `TIME` command to set the clock.
  2. Apply three-phase voltages. Execute the `METER` command and make sure the readings are accurate. If they are not, be sure the correct PT ratio was entered. Remember that displayed values are in primary line-to-line volts.
  3. Use the `TRIGGER` command to generate an event record. Type `EVENT 1 <ENTER>` and examine the event record. Refer to the top row of data as the "Y" components and the next row as the "X" components. Using the SEL Direction and Polarity Check Form at the end of this section, plot the three voltage phasors to ensure that they are  $120^\circ$  apart, of reasonable magnitudes, and rotating in the positive-sequence direction. The zero-sequence voltage Y and X components (times a factor of three) are the totals of the three Y components and the three X components. These sums should be near zero if balanced three-phase potentials are present.
  4. Use the `TARGET` command to check all inputs (IN1-IN6). Type `TAR 7 <ENTER>` and the front panel target LEDs display input states. Corresponding targets and inputs appear below:

INST	A	B	C	G	RS	CY	LO	Front Panel Targets
		IN6	IN5	IN4	IN3	IN2	IN1	Inputs

An LED illuminates when a corresponding input is energized with nominal control voltage. Apply nominal control voltage to each input and make sure the corresponding LED illuminates. When the test is complete, type `TAR R <ENTER>` to reset and clear the front panel target LEDs.

5. Proceed to Access Level 2 with the `2ACCESS` command and second password. Be sure the `ALARM` relay contacts close and open when the relay executes the `2ACCESS` command. The `ALARM` pulse will not be detectable if the `ALARM` contacts are closed due to an alarm condition.



6. Test the TRIP output contacts by executing the OPEN command (The OPEN/CLOSE command enable jumper JMP104 must be in place). The TRIP output contacts remain asserted for at least the length of the TDUR (trip duration) setting and will not deassert until all overcurrent elements in Relay Word row R1 drop out or you press the front panel TARGET RESET button.
7. Test the CLOSE output contact by executing the CLOSE command (the OPEN/CLOSE command enable jumper JMP104 must be in place). CLOSE output contact operation requires that a 52A, !52A, 52AR, or !52AR function be assigned to an input (for example, IN6=52A). With IN6 de-energized (circuit breaker open), execute the CLOSE command.

The CLOSE contacts remain asserted for as long as the CFT (close failure time) setting unless the TRIP output contact is asserted or IN6 is energized (circuit breaker apparently closed). If CFT = 0, CLOSE remains asserted indefinitely unless TRIP is asserted or IN6 is energized (circuit breaker closed).

8. Test the programmable output contacts A1, A2, A3, and A4. Using the SET command, set these contacts to assert when input IN5 is energized. IN5 is in Relay Word row R3 and accessible by A1, A2, A3, and A4 output contact settings:

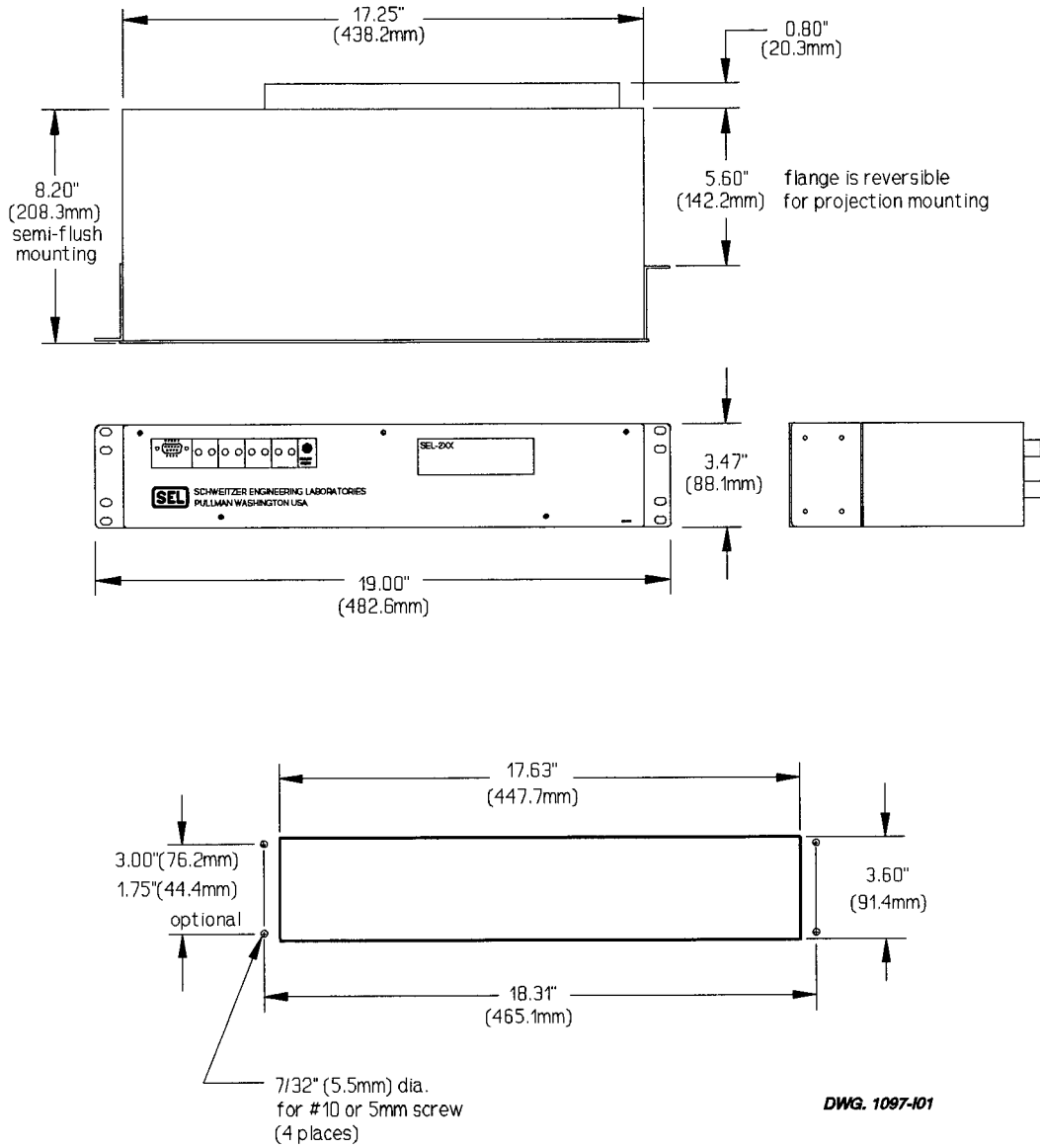
A1(1234) = IN5  
A2(1234) = IN5  
A3(1346) = IN5  
A4(2346) = IN5

After entering the previous settings, apply nominal control voltage to input IN5 and observe A1, A2, A3, and A4 output contact assertion.

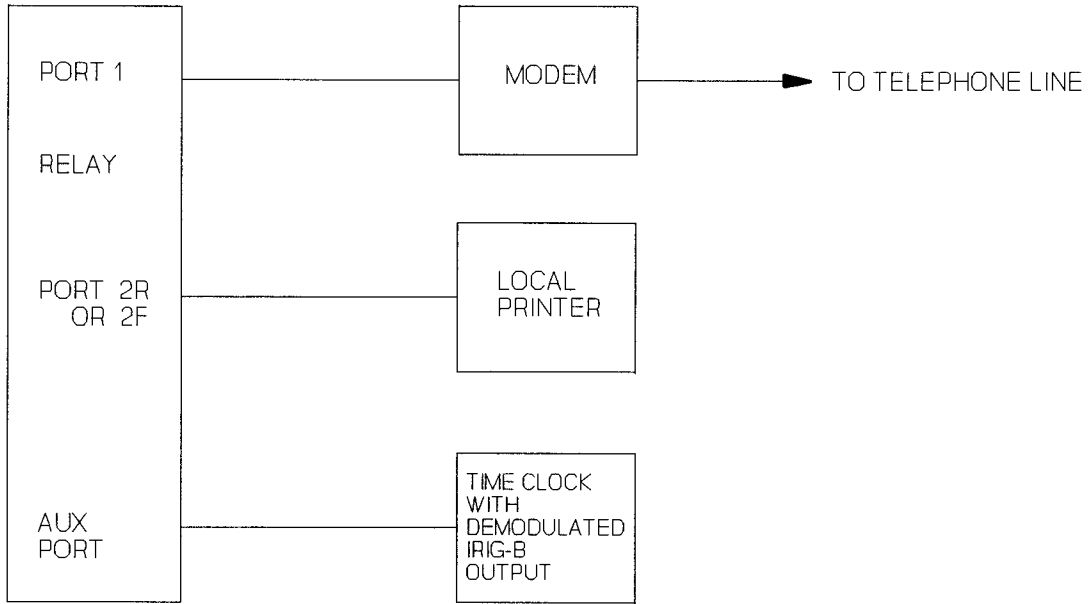
9. Use the STATUS command to inspect the self-test status. You may wish to save the reading as part of an as-left record.

When local checkout is complete, check communications with the instrument via a remote interface (if used). Make sure the automatic port is properly assigned and that desired timeout intervals are selected for each port. Also, be sure to record password settings.

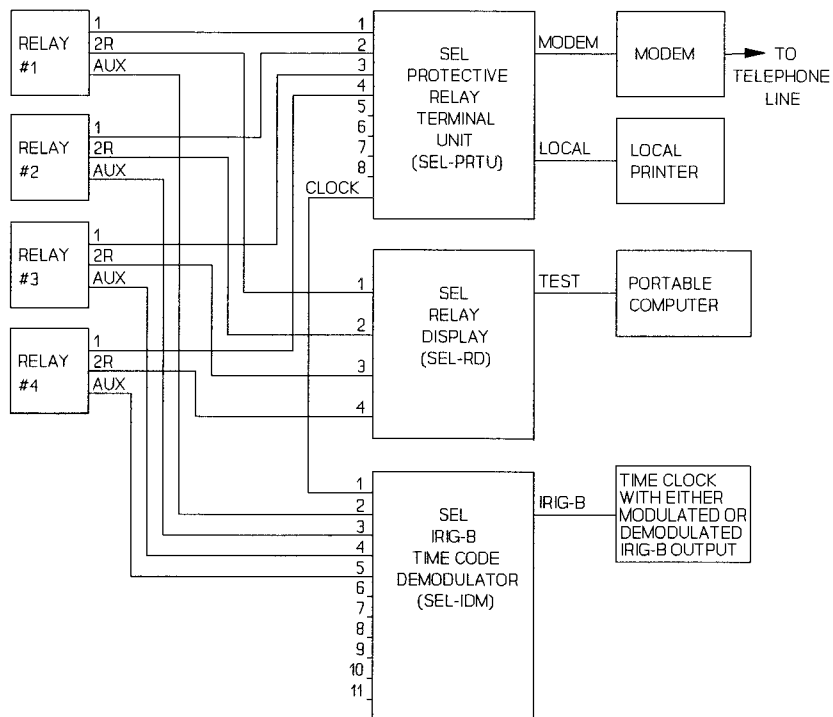




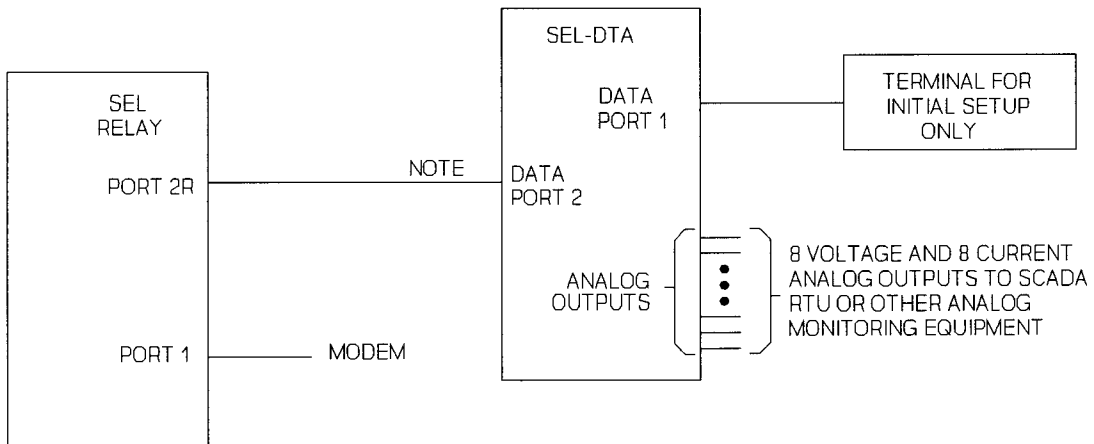
**Figure 6.3: SEL-200 Series (Shallow) Relay Dimensions, Panel Cutout, and Drill Diagrams**



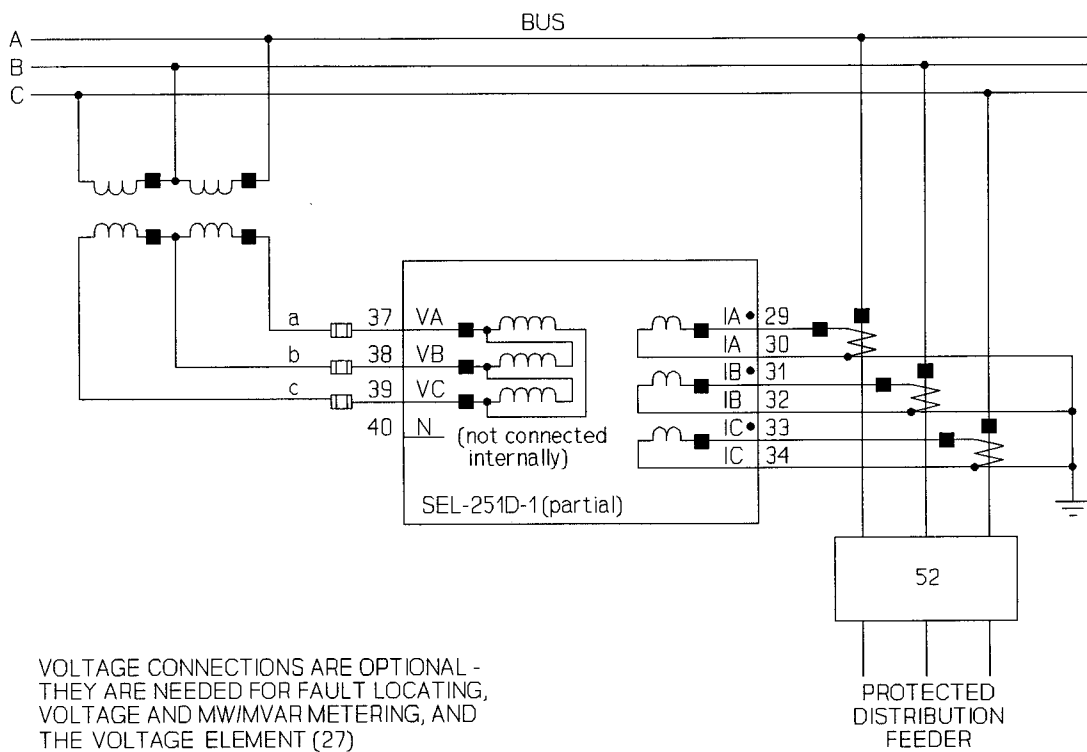
**Figure 6.4: Communications and Clock Connections - One Unit at One Location**



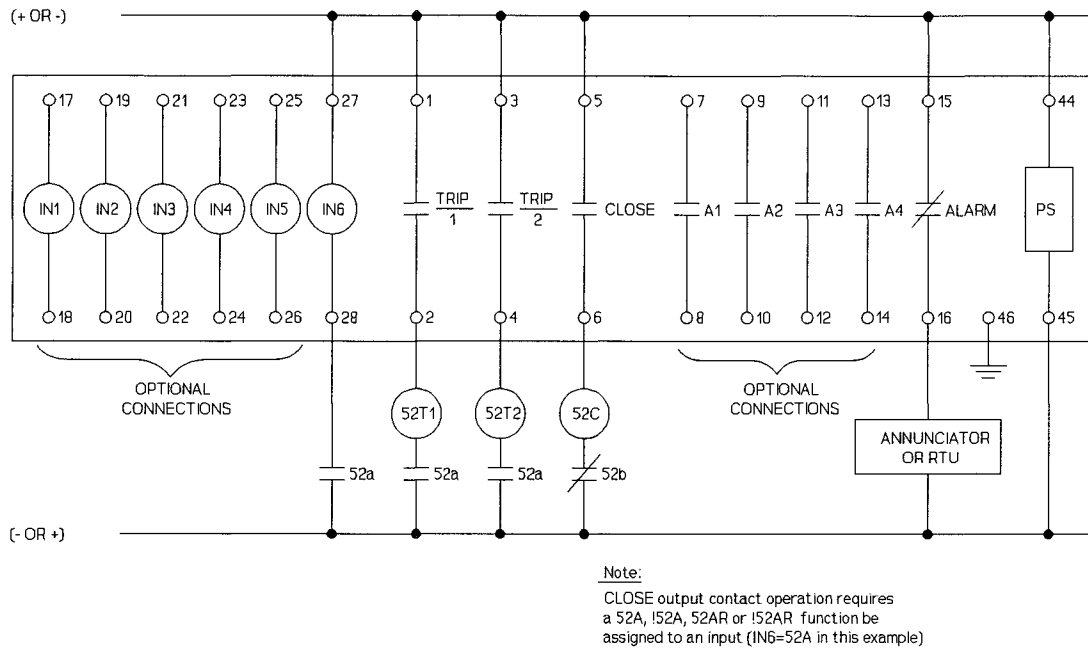
**Figure 6.5: Remote Communications, Local Display, and Clock Connections - Multiple Relay Units at One Location**



**Figure 6.6: SEL Relay Communications Diagram for Connection to the SEL-DTA**



**Figure 6.7: SEL-251D-1 Relay Typical AC External Current and Voltage Connections**



**Figure 6.8: SEL-251D-1 Relay Typical DC External Connections**

SEL DIRECTION AND POLARITY CHECK FORM

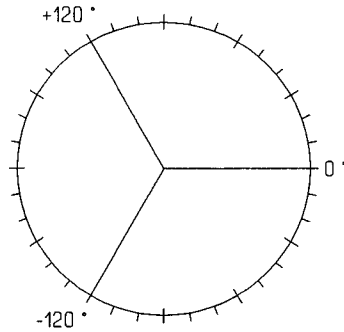
STATION \_\_\_\_\_ DATE: \_\_\_/\_\_\_/\_\_\_ TESTED BY \_\_\_\_\_  
 SWITCH NO. \_\_\_\_\_ EQUIPMENT \_\_\_\_\_  
 INSTALLATION \_\_\_\_\_ ROUTINE \_\_\_\_\_ OTHER \_\_\_\_\_

LOAD CONDITIONS:

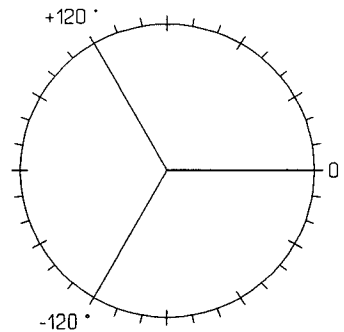
STATION READINGS: \_\_\_\_\_ MW (OUT)(IN) \_\_\_\_\_ MVAR (OUT)(IN) \_\_\_\_\_ VOLTS \_\_\_\_\_ AMPS  
 SEL READINGS: \_\_\_\_\_ MW (+)(-) \_\_\_\_\_ MVAR (+)(-)

AS SEEN ON SCREEN	Ia	Ib	Ic	Va	Vb	Vc	
COMPANY NOTATION	I( )	I( )	I( )	V( )	V( )	V( )	
1st LINE CHOSEN (Y COMPONENT)							
2nd LINE CHOSEN (X COMPONENT)							
CALCULATED MAGNITUDE $\sqrt{X^2 + Y^2}$							ROW 1
ANGLE IN DEGREES ARCTAN Y/X							
VALUE OF Va DEGREES TO SUBTRACT TO OBTAIN Va DEGREES = 0							
@ Va DEGREES = 0, ANGLE USED TO DRAW PHASOR DIAGRAM							ROW 2

USE THE VALUES IN ROWS 1 AND 2 ABOVE TO DRAW PHASOR DIAGRAMS BELOW



CURRENTS



VOLTAGES





SEL DIRECTION AND POLARITY CHECK FORM

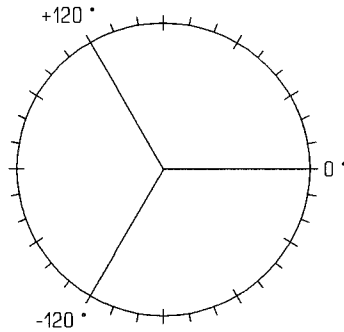
STATION \_\_\_\_\_ DATE: \_\_\_/\_\_\_/\_\_\_ TESTED BY \_\_\_\_\_  
 SWITCH NO. \_\_\_\_\_ EQUIPMENT \_\_\_\_\_  
 INSTALLATION \_\_\_\_\_ ROUTINE \_\_\_\_\_ OTHER \_\_\_\_\_

LOAD CONDITIONS:

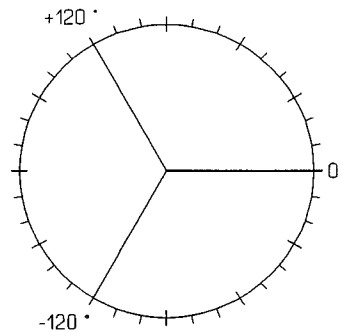
STATION READINGS: \_\_\_\_\_ MW (OUT)(IN) \_\_\_\_\_ MVAR (OUT)(IN) \_\_\_\_\_ VOLTS \_\_\_\_\_ AMPS  
 SEL READINGS: \_\_\_\_\_ MW (+)(-) \_\_\_\_\_ MVAR (+)(-)

AS SEEN ON SCREEN	Ia	Ib	Ic	Va	Vb	Vc	
COMPANY NOTATION	I( )	I( )	I( )	V( )	V( )	V( )	
1st LINE CHOSEN (Y COMPONENT)							
2nd LINE CHOSEN (X COMPONENT)							
CALCULATED MAGNITUDE $\sqrt{X^2 + Y^2}$							ROW 1
ANGLE IN DEGREES ARCTAN Y/X							
VALUE OF Va DEGREES TO SUBTRACT TO OBTAIN Va DEGREES = 0							
@ Va DEGREES = 0, ANGLE USED TO DRAW PHASOR DIAGRAM							ROW 2

USE THE VALUES IN ROWS 1 AND 2 ABOVE TO DRAW PHASOR DIAGRAMS BELOW



CURRENTS



VOLTAGES



# MAINTENANCE & TESTING

## TABLE OF CONTENTS

Test Procedures . . . . .	7-1
Initial Checkout . . . . .	7-4
Full Functional Test . . . . .	7-12
Setting Test . . . . .	7-13
Overcurrent Element Pickup Tests . . . . .	7-13
Definite-Time Overcurrent Element Timing Tests . . . . .	7-14
Time-Overcurrent Element Timing Tests . . . . .	7-15
Demand Ammeter Timing Tests . . . . .	7-17
Reclosing Relay Tests Setup . . . . .	7-18
Reclosing Relay Reset Interval Timer Test . . . . .	7-19
Reclosing Relay Open Interval Timer Test . . . . .	7-20
Reclosing Relay States Test . . . . .	7-21
Reclosing Relay Shot Bit Test . . . . .	7-22
Reclosing Relay Sequence Coordination Test . . . . .	7-24
Close Failure Timer Test . . . . .	7-26
Trip Failure Timer Test . . . . .	7-27
Input Circuits Test . . . . .	7-29
Serial Ports Test . . . . .	7-30
IRIG-B Time Code Input Test . . . . .	7-30
Power Supply Voltages Test . . . . .	7-30
Relay Calibration . . . . .	7-31
Troubleshooting . . . . .	7-31
Firmware Upgrade Instructions . . . . .	7-34
Factory Assistance . . . . .	7-36

### TABLES

Table 7.1: Fault Locator Test Values . . . . .	7-11
Table 7.2: Current Quantities for 51NT Timing Test Example . . . . .	7-16
Table 7.3: Contact Inputs and Terminal Numbers . . . . .	7-29

### FIGURES

Figure 7.1 Low-Level Test Interface . . . . .	7-2
Figure 7.2: Relay Part Number and Hardware Identification Sticker . . . . .	7-5
Figure 7.3: Communication Interface Setup . . . . .	7-6
Figure 7.4: Three-Phase Voltage and Current Source Test Connections . . . . .	7-10
Figure 7.5: 9-Pin Connector Pin Number Convention . . . . .	7-30



# MAINTENANCE & TESTING

---

## TEST PROCEDURES

### Test Aids Provided by the Relay

The following features assist you during relay testing and calibration.

**METER Command**            The METER command shows the voltages and currents presented to the relay in primary values. The relay calculates megawatts (MW) and megavars (MVAR) from these voltages and currents. These quantities are useful for comparing relay calibration against other meters of known accuracy.

When testing the relay, first verify relay calibration. Consider all tests invalid if you determine that the relay is out of calibration. Each relay is calibrated at the factory prior to shipment and should not require further adjustment. If calibration is necessary, refer to Calibration in this section.

**TARGET Command**            The relay allows you to reassign front panel targets to indicate elements and intermediate logic results in the Relay Word as well as input and output contact status. Use the TARGET command to reassign the front panel LEDs. Once target LEDs are reassigned from the default targets, the front panel targets are no longer latching. This means the targets follow the pickup and dropout condition in much the same manner as an output contact. See Section 3: COMMUNICATIONS for more information about the TARGET command.

By employing the target LEDs for testing, you need not change the relay settings for testing purposes.

**Event Reporting**            The relay generates an eleven-cycle event report in response to a trip condition or other user-selected conditions. Each event report contains voltage and current information, relay element states, and input/output contact information in quarter-cycle resolution. If you question the relay response or your test method, use the event report for assistance.

Each event report is date and time tagged relative to the sixteenth quarter-cycle of the event report. Each report is triggered upon assertion of designated relay elements and/or contact inputs and outputs. If the time-out of a protective element results in TRIP output contact closure, the trip generates a second event report. Thus, the relay generates two event reports: the first when the designated instantaneous element asserts, the second when the TRIP output contact closes. Where time delayed pickup (TDPU) timers are concerned, use the event report time tag to determine

the validity of a TDPU timer setting. Simply subtract the latest event report time tag from the previous event report time tag. Section 2: SPECIFICATIONS has further details concerning event report generation.

SELOGIC™ Control Equations SELOGIC Control Equations allow you to isolate individual relay elements. See the SET n p command description in Section 3: COMMUNICATIONS for more information.

**Low-Level Test Interface (patents pending)**

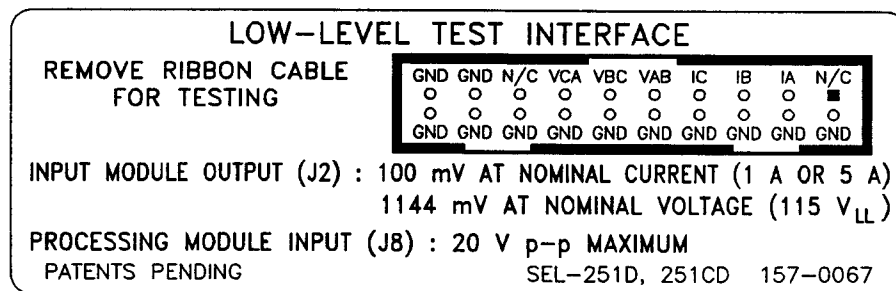
The SEL-251D-1 Relay has low-level test interface between the calibrated input module and the separately-calibrated processing module. You may test the relay in either of two ways: conventionally, by applying ac current signals to the relay inputs; or by applying low magnitude ac voltage signals to the low-level test interface. Access the test interface by removing the relay front panel.

Figure 7.1 shows the interface connections. This drawing also appears on the inside of the relay front panel. Remove the ribbon cable between the two modules to access the outputs of the input module and the inputs to the processing module (relay main board).

You can test the relay processing module using signals from the SEL-RTS Low-Level Relay Test System. Never apply voltage signals greater than 20 volts peak-peak to the low-level test interface. Figure 7.1 shows the signal scaling factors.

You can test the input module two different ways:

- Measure the outputs from the input module with an accurate voltmeter, and compare the readings to accurate instruments in the relay input circuits, or
- replace the ribbon cable, execute the METER command, and compare the relay readings to accurate instruments in the relay input circuits.



**Figure 7.1: Low-Level Test Interface**

## **Test Methods**

There are two means of determining the pickup and dropout of relay elements: target lamp illumination and output contact closure.

### **Testing Via Target LED Illumination**

During testing you can use target lamp illumination to determine relay element status. Using the TARGET command, set the front panel targets to display the element under test. For example, the overcurrent element pickups appear in Relay Word row 1. When you type the command **TARGET 1 <ENTER>**, the LEDs display the status of the elements in Relay Word row 1. Thus, with Target 1 displayed, if the phase time-overcurrent element pickup (**51P**) asserts, the left most LED illuminates. Using LED illumination as an indicator, you can measure the element operating characteristics.

When the TARGET command sets target LED output to a level other than 0 (Relay Targets), the front panel target markings no longer correspond to illuminated LEDs and the LEDs do not latch.

If you place the relay in service with a target level other than Level 0, it automatically returns to Level 0 when an automatic message transmits to a timed out port. While this feature prevents confusion among station operators and readers, it can be inconvenient if the relay tester does not want targets to revert to Level 0.

To simplify testing using targets, set the relay AUTO setting equal to the port which you intend to use. Also, set that port TIME setting equal to zero. This prevents automatic message transmission to a port which may be timed out. Remember to reset these settings and the target level before returning the relay to service following tests.

### **Testing Via Output Contact Assertion**

To test using this method, set one programmable output contact to assert when the element under test picks up. With the SET n p command, set an output contact equal to the element under test.

For an "a" contact, when the condition asserts, the output contact closes; when the condition deasserts, the output contact opens.

For a "b" contact, when the condition asserts, the output contact opens. When the condition deasserts, the output contact closes. Programmable contacts can be specified at the factory as "a" or "b." Using contact operation as an indicator, you can measure element operating characteristics, stop timers, etc.

Tests in this section use the output contact method and assume an "a" output contact.

## Using a Breaker Simulator

Because much of the relay logic depends on whether the breaker is open or closed, it is important to use a breaker simulator. The following logic depends on the state of the circuit breaker status input:

- Reclosing Relay Logic
- Close Function Logic
- Trip Circuit Monitor Logic
- 52AT and 52BT Functions
- Circuit Breaker Monitor Logic

We recommend testing the SEL-251D-1 Relay with a latching relay to simulate line breaker auxiliary contact action. This ensures proper assertion and deassertion of the circuit breaker status function assigned to an input on the back panel.

## INITIAL CHECKOUT

The initial checkout procedure should familiarize you with the relay and ensure that all functions are operational. Study Functional Specification and Description in Section 2: SPECIFICATIONS, Command Descriptions in Section 3: COMMUNICATIONS, and Section 4: EVENT REPORTING for a complete understanding of the relay capabilities.

### Equipment Required

The following equipment is necessary for initial checkout.

1. Terminal with EIA RS-232-C serial interface
2. Interconnecting cable between terminal and relay
3. Source of control power
4. Source of three-phase voltages and currents
5. Ohmmeter or contact opening/closing sensing device

### Checkout Procedure

In the procedure below, you will use several relay commands. Section 3: COMMUNICATIONS provides a full explanation of all commands. The following information should allow you to complete the checkout without referring to the detailed descriptions.

**Note:** In this manual, commands to type appear in bold/upper case: **OTTER**. Keys to press appear in bold/upper case/brackets: **<ENTER>**.



Relay output appears in the following format:

Example 21.6 kV distribution feeder	Date: 4/1/93	Time: 01:01:01
-------------------------------------	--------------	----------------

■ **Step 1**

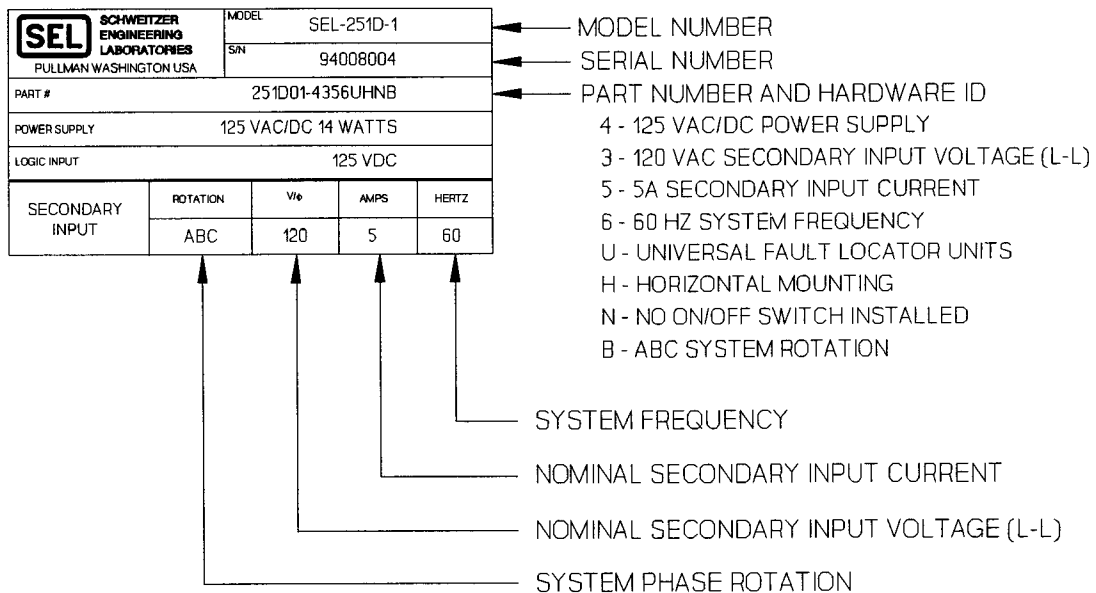
**Purpose:** Be sure you received the relay in satisfactory condition.

**Method:** Inspect the instrument for physical damage such as dents or rattles.

■ **Step 2**

**Purpose:** Verify the requirements for the relay logic inputs, control power voltage level, and voltage and current inputs.

**Method:** Refer to the information sticker on the rear panel of the relay. Figure 7.2 provides an example. Please read the information on this sticker before applying power to the relay or starting tests. Be sure your dc supply is correctly adjusted for the control and logic input requirements.

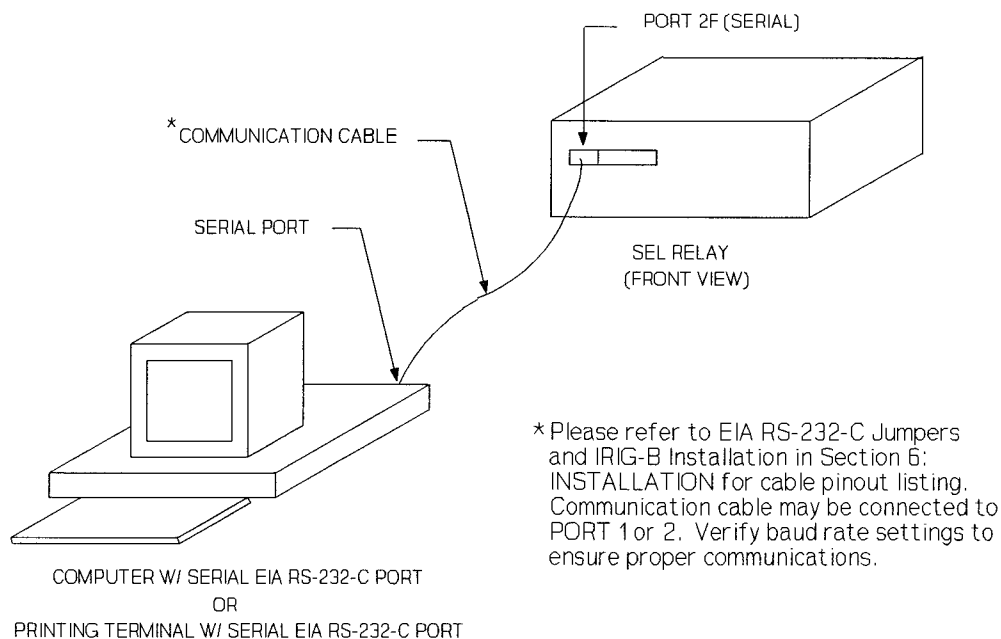


**Figure 7.2: Relay Part Number and Hardware Identification Sticker**

### ■ Step 3

**Purpose:** Verify the communications interface setup.

**Method:** Connect a computer terminal to Port 2F on the relay front panel. The terminal should be configured to 2400 baud, eight data bits, two stop bits, and no parity. The relay is shipped from the factory with Port 2 set to 2400 baud and Port 1 set to 300 baud. Section 3: COMMUNICATIONS provides additional details on port configuration. Baud rate selection is described under Jumper Selection in Section 6: INSTALLATION. Figure 7.3 shows the typical communication interface setup for testing purposes.



**Figure 7.3: Communication Interface Setup**

### ■ Step 4

**Purpose:** Establish control power connections.

**Method:** Connect a frame ground to terminal 46 on the rear panel and connect rated control power to terminals 44 and 45. Polarity is unimportant. Relays supplied with 125 or 250 V power supplies may be powered from a 115 Vac wall receptacle for testing. In the final installation, we recommend that the relay receive control power from the station dc battery to avoid losing events stored in volatile memory if station service is lost.

## ■ Step 5

**Purpose:** Apply control voltage to the relay and start Access Level 0 communications.

**Method:** Turn on the relay power. All front panel targets should illuminate when you press the TARGET RESET button. If not, be sure that power is present and check the fuse or fuses. The following message should appear on the terminal:

```
Example 21.6 kV distribution feeder      Date: 4/1/93      Time: 01:01:01
SEL-151
=
```

The ALARM relay should pull in, holding its "b" contacts (terminals 15,16) open. If the relay pulls in but no message is received, check the terminal configuration. If neither occurs, turn off the power and refer to Troubleshooting later in this section.

The = prompt indicates that communications with the relay are at Access Level 0, the first of three levels. The only command accepted at this level is ACCESS, which opens communications on Access Level 1.

**Note:** If you are using a battery simulator, be sure the simulator voltage level is stabilized before turning the relay on.

## ■ Step 6

**Purpose:** Establish Access Level 1 communications.

**Method:** Type ACCESS and press <ENTER>. At the prompt, enter the Access Level 1 password OTTER and press <ENTER>. The => prompt should appear, indicating that you have established communications at Access Level 1.

■ **Step 7**

**Purpose:** Verify relay self-test status.

**Method:** Type **STATUS** and press **<ENTER>**. The following display should appear on the terminal:

```
Example 21.6 kV distribution feeder           Date: 4/1/93   Time: 01:04:56
SELF-TESTS
W=Warn  F=Fail
      IR  IA  IB  IC  VAB  VBC  VCA
OS    0   0   0   0   0    0   0
PS    5.08 14.92 -14.99
RAM   ROM  A/D  MOF  SET
OK    OK  OK   OK   OK
=>
```

■ **Step 8**

Purpose: View the demonstration settings entered before shipment.

Method: The relay is shipped with demonstration settings; type **SHOWSET 1** <ENTER> to view them. The terminal should display the following:

```

=>SHOWSET 1 <ENTER>
Settings for group 1

Example 21.6 kV distribution feeder
CTR =120.00 PTR =180.00
R1 =0.58 X1 =1.50 RO =1.44 X0 =4.56
ROS =0.05 XOS =0.53 LL =2.42
DATC =15 PDEM =12.00 NDEM =12
79O11=30 79O12=0 79O13=0 79O14=0
79RST=1800 M79SH=10000
50C =99.99 27L =0.00 27H =0.00 27C =2 TCI =0
50G =99.99 50GT =0
51GP =12.00 51GTD=15.00 51GC =4 51GRS=N
50NL =2.01 50NLT=0 50NH =39.99
51NP =1.50 51NTD=3.00 51NC =4 51NRS=N
50L =99.99 50LT =0 50H =39.99
51P =6.00 51TD =5.00 51C =4 51RS =N
52APU=0 52ADO=0 TSPU =0 TSDO =0
TKPU =1 TKDO =0 TZPU =0 TZDO =0

PRESS RETURN ? <ENTER>

SELogic Equations

S(123) =
A(12) = 50NL
B(12) = 50NH+51NT
C(12) =
D(12) =
E(34) =
F(34) =
G(34) =
H(34) = IN6
J(1234) = 79SH
K(1234) = IN5
L(1234) =
A1(1234)=
A2(1234)=

PRESS RETURN ? <ENTER>

V(56) = A*H*J
W(56) = B*H
X(56) = J*KT
Y(56) =
Z(56) =
A3(1346)=
A4(2346)=
TR(1246)= 50H+51T+V+W+X
RC(1246)=
ER(1246)=
SEQ(1) =
ETC(1) = 51P
ITC(1) =

Global settings
DEMR =Y CFT =0 TDUR =4 TFT =0 TGR =180
ITT =5 TIME1=15 TIME2=0 AUTO =2 RINGS=3
IN1 = IN2 =TCP IN3 =!RE IN4 =52A
IN5 = IN6 =

=>

```

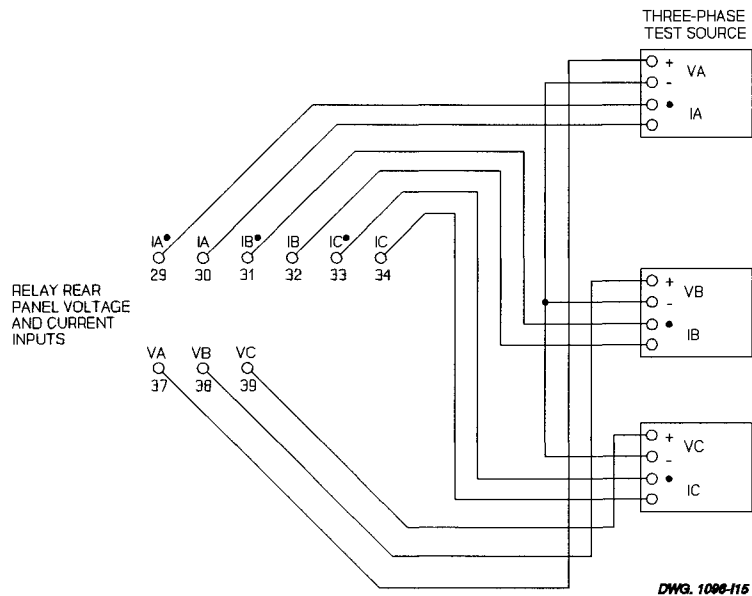
The SET command descriptions in Section 3: COMMUNICATIONS include a complete explanation of the settings.

■ **Step 9**

**Purpose:** Connect voltage and current sources to the relay.

**Method:** Turn power off and connect the sources of voltage and current to the rear panel terminals of the relay as shown in Figure 7.4. Apply 69 volts per phase (i.e.,  $V_A = 69$ ) in positive-sequence rotation.

Set the  $A\phi$  current source to 2 amperes, at the same angle as the  $A\phi$  voltage. Set the  $B\phi$  current source to 2 amperes, at the same angle as the  $B\phi$  voltage. Set the  $C\phi$  current source to 2 amperes, at the same angle as the  $C\phi$  voltage.



**Figure 7.4: Three-Phase Voltage and Current Source Test Connections**

■ **Step 10**

**Purpose:** Verify correct voltage and current connections and levels.

**Method:** Use the METER command to measure the voltages and currents applied in Step 9. With applied voltages of 69 volts per phase and a potential transformer ratio of 180:1 for delta-connected potential transformers, the displayed line-to-line voltages should be 21600 V. With applied currents of 2.0 amperes per phase and a current transformer ratio of 120:1, the displayed line-to-neutral currents should be 240 amperes. All line-to-line quantities should be

balanced, differing from the line-to-neutral measurements by a factor of 1.73. Real power P should be approximately 8.94 MW; reactive power Q should be approximately 0 MVAR.

```
=>METER <ENTER>
Example 21.6 kV distribution feeder           Date: 4/1/93   Time: 09:12:49

MET IA=240   B=239   C=242   R=6
  P=8.942   Q=0.054

VAB=21501  VBC=21512  VCA=21513

=>
```

If you inadvertently switched a pair of voltages or currents, the MW reading should be incorrect. It is important to remember this when commissioning the relay using system voltages and currents.

■ **Step 11**

Purpose: Establish Access Level 2 communications.

Method: Type **2ACCESS** and press **<ENTER>**. At the prompt, enter the Access Level 2 password **TAIL** and press **<ENTER>**. The **=>>** prompt should appear, indicating that you have established communications at Access Level 2.

■ **Step 12**

Purpose: Test the fault locator.

Method: Test the fault locator using the voltages and currents in Table 7.1. These voltages and currents were obtained for AG and BC fault types assuming a radial line with a positive-sequence source impedance of  $Z1 = 0.25 + j2.50 \Omega$  (21.6 kV).

Use the following settings:

```
CTR = 120
PTR = 180
R1 = 0.58
X1 = 1.50
R0 = 1.44
X0 = 4.56
R0S = 0.05
X0S = 0.53
LL = 2.42
```

Set one of the phase pickups (51P, 50L, or 50H) below 10.00 A secondary and enable this same pickup to generate an event report [ER(1246) setting]. Remember that the line length (LL) setting is unitless.

LOCATION	TYPE	VA	VB	VC	IA	IB	IC	UNITS
7.26	AG	56.49	66.33	67.88	10.60	0.00	0.00	V or A
		-2.5	-116.9	116.3	-73.5	0.00	0.00	Degrees
7.26	BC	69.28	55.09	50.29	0.00	12.38	12.38	V or A
		0.00	-134.0	128.1	0.00	-164.2	15.81	Degrees

To view the full event report for the last fault, type **EVENT 1** and press **<ENTER>**. Each event report provides an eleven cycle record of the currents, voltages, relay element states, and all contact input and output states. The relay saves the twelve newest reports.

This checkout procedure demonstrates only a few relay features. For a complete understanding of relay capabilities, study Functional Description in Section 2: SPECIFICATIONS, the command descriptions in Section 3: COMMUNICATIONS, and Section 4: EVENT REPORTING. For more test procedures, see the Full Functional Test portion of this section.

## FULL FUNCTIONAL TEST

This procedure allows you to test the protective and control functions of the relay more fully than the initial checkout procedure does.

### Equipment Required

The following equipment is necessary to complete a full functional test:

1. Communications terminal with EIA RS-232-C serial interface
2. Data cable to connect terminal and relay
3. Source of relay control power
4. Source of synchronized three-phase voltages and at least two currents
5. Ohmmeter or contact opening/closing sensing device
6. Timer with contact inputs for start and stop



## What Should Be Tested

A full functional test includes the initial checkout procedure and the additional steps described below. In general, these tests assure that the relay settings match your application rather than checking relay performance. For commissioning purposes, your company policy may require you to perform the full functional test. For maintenance purposes, a quick test of selected fault types and elements should suffice.

## SETTING TEST

Purpose: Ensure that the relay accepts settings.

- Method:
1. Gain Level 2 Access (see ACCESS and 2ACCESS commands in Section 3: COMMUNICATIONS).
  2. Change one setting in setting group 1. For example, change the ground/residual time-overcurrent element pickup from 1.5 amperes secondary to 2.0 amperes secondary.

Type **SET 1 51NP** and press **<ENTER>**.

Following the 51NP prompt, type **2.0** and press **<ENTER>**.

3. To complete the setting procedure, type **END** and press **<ENTER>**. Type **Y <ENTER>** at the prompt: "OK (Y or N) ?" The relay computes internal settings and compares them against fixed limits. If all settings are within acceptable ranges, the ALARM contact closes momentarily as the new settings are enabled unless an alarm condition already exists (e.g., self-test failure).
4. Use the SHOWSET command to inspect settings. Make sure your change was accepted.

Type **SHOWSET 1** and press **<ENTER>**.

5. Use SET and SHOWSET again to restore the initial values and check the settings.

## OVERCURRENT ELEMENT PICKUP TESTS

Purpose: Verify the pickup thresholds of the following overcurrent elements:

- |            |  |
|------------|--|
| <b>51P</b> | Phase time-overcurrent element pickup          |
| <b>50L</b> | Phase definite-time overcurrent element pickup |
| <b>50H</b> | Phase instantaneous overcurrent element        |

- 51GP** Ground/Residual time-overcurrent element pickup
- 50G** Ground/Residual definite-time overcurrent element pickup
- 51NP** Ground/Residual time-overcurrent element pickup
- 50NL** Ground/Residual definite-time overcurrent element pickup
- 50NH** Ground/Residual instantaneous overcurrent element

- Method:
1. Using the SET command, set the desired programmable output (A1-A4) to follow the appropriate overcurrent element. Select one of the overcurrent elements from the first row of the Relay Word listed above.
  2. Disable all external and internal torque control on the overcurrent elements. Using the SET command, enter NA for the ETC(1) and ITC(1) settings. These settings specify the overcurrent elements in Relay Word row R1 you want externally and internally torque controlled (none in this case).
  3. Apply current to one phase and observe the pickup and dropout of each element. Record the results.

**Note:** With current applied to only one phase (e.g.,  $I_A = 6 \text{ A}$ ,  $I_B = I_C = 0$ ), the following zero-sequence current results:

$$\begin{aligned}
 I_0 &= \frac{1}{3} [I_A + I_B + I_C] \\
 &= \frac{1}{3} [6 \text{ A } \angle 0^\circ + 0 \text{ A } \angle 0^\circ + 0 \text{ A } \angle 0^\circ] \\
 &= 2 \text{ A } \angle 0^\circ
 \end{aligned}$$

The ground/residual overcurrent elements respond to  $3 \times I_0$  current. Thus, for this test all overcurrent elements see 6 A.

## DEFINITE-TIME OVERCURRENT ELEMENT TIMING TESTS

Purpose: Verify operating times for the following definite-time overcurrent elements.

- 50LT** Phase definite-time overcurrent element
- 50GT** Ground/Residual definite-time overcurrent element
- 50NLT** Ground/Residual definite-time overcurrent element

- Method:
1. Disable all external and internal torque control on the definite-time overcurrent element pickups in Relay Word row R1. The above definite-time overcurrent elements are derived from their respective pickups in Relay Word row R1. If one of these pickups in Relay Word row R1 is torque controlled, the respective definite-time overcurrent element it drives in Relay Word row R2 is also torque controlled.

Using the SET command, enter **NA** for the ETC(1) and ITC(1) settings. These settings specify the overcurrent elements in Relay Word row R1 you want externally and internally torque controlled, respectively (none in this case).

2. Set a programmable output (A1-A4) to follow a definite-time overcurrent element pickup (e.g., **50NL**). Use the assertion of this output (open to close) to start an external timer.
3. Set another programmable output to follow definite-time overcurrent element timeout via Relay Word bit 50NLT (**50NL** drives **50NLT**). Use the assertion of this output to stop the external timer.
4. Apply current to one phase over the 50NL pickup setting. The time shown on the timer should match the 50NLT time delay setting.

**Note:** With current applied to only one phase (e.g.,  $I_A = 6 \text{ A}$ ,  $I_B = I_C = 0$ ), the following zero-sequence current results:

$$\begin{aligned}
 I_0 &= \frac{1}{3} [I_A + I_B + I_C] \\
 &= \frac{1}{3} [6 \text{ A } \angle 0^\circ + 0 \text{ A } \angle 0^\circ + 0 \text{ A } \angle 0^\circ] \\
 &= 2 \text{ A } \angle 0^\circ
 \end{aligned}$$

The ground/residual overcurrent elements respond to  $3 \times I_0$  current. Thus, for this test all overcurrent elements see 6 A.

5. Repeat these tests for elements **50LT** and **50GT**.

## TIME-OVERCURRENT ELEMENT TIMING TESTS

**Purpose:** Verify the operating times of the following time-overcurrent elements.

- 51T** Phase time-overcurrent element
- 51GT** Ground/Residual time-overcurrent element
- 51NT** Ground/Residual time-overcurrent element

**Method:**

1. Disable all external and internal torque control on the time-overcurrent element pickups in Relay Word row R1. The above time-overcurrent elements are derived from their respective pickups in Relay Word row R1. If a time-overcurrent element pickup in row R1 is torque controlled, the respective time-overcurrent element it drives in Relay Word row R2 is also torque controlled.

Using the SET command, enter **NA** for the ETC(1) and ITC(1) settings. These settings specify the overcurrent elements in Relay Word row R1 you want externally and internally torque controlled, respectively (none in this case).

2. Set a programmable output (A1-A4) to follow a time-overcurrent element pickup (e.g., **51NP**). Use the assertion of this output (open to close) to start an external timer.

3. Set another programmable output to follow time-overcurrent element timeout via the **51NT** bit in the Relay Word (**51NP** drives **51NT**). Use the assertion of this output to stop the external timer.
4. Calculate the expected operating time of **51NT** using the appropriate equation for the curve number (see Time-Overcurrent Curve-Timing and Time Delay Reset Equations in Section 2: SPECIFICATIONS). This is dictated by the **51NC** setting. TD is the **51NTD** time dial setting. M is the multiple of pickup current to be applied to the relay. Using example relay settings and a current multiple of pickup equal to three, the equation for the very inverse curve (**51NC** = 3) is:

$$t_M = TD \left( 0.0963 + \frac{3.88}{M^2 - 1} \right)$$

Where M = Multiples of Pickup = 3  
 TD = Time Dial = 4

$$t_M = 2.33 \text{ seconds}$$

For example, if the relay measures 3.45 amperes of residual current, the **51NT** bit in the Relay Word asserts 2.33 seconds after **51NP** assertion (**51NP** = 1.15 A;  $3 \times 1.15 = 3.45$ ). Table 7.2 shows current quantities for the previous example.

**Table 7.2: Current Quantities for 51NT Timing Test Example**

IA	IB	IC	
3.45	0.00	0.00	Amperes
0.0°	0.0°	0.0°	Degrees

5. Apply a multiple of pickup current to one phase. Record the **51NT** element operating time and compare it to the calculated time.

**Note:** With current applied to only one phase (e.g.,  $I_A = 3.45 \text{ A}$ ,  $I_B = I_C = 0$ ), the following zero-sequence current results:

$$\begin{aligned} I_0 &= \frac{1}{3} [I_A + I_B + I_C] \\ &= \frac{1}{3} [3.45 \text{ A } \angle 0^\circ + 0 \text{ A } \angle 0^\circ + 0 \text{ A } \angle 0^\circ] \\ &= 1.15 \text{ A } \angle 0^\circ \end{aligned}$$

The ground/residual overcurrent elements respond to  $3 \times I_0$  current. Thus, for this test all overcurrent elements see 3.45 A.

6. Optional: You may want to repeat this test with various multiples of pickup current (e.g., M = 3, 5, and 7) and various time dial settings (e.g., TD = 1, 5, and 10) for each of the four curve indexes.
7. Repeat these tests for elements **51T** and **51GT**.

## DEMAND AMMETER TIMING TESTS

**Purpose:** Verify the operating time of the following demand ammeter thresholds.

**PDEM** Phase demand current threshold exceeded

**NDEM** Residual demand current threshold exceeded

- Method:**
1. Using the SET command, set a programmable output contact (A1-A4) to follow one of the demand ammeter threshold alarms from Relay Word row R4 (e.g., **NDEM**). Also, set the respective demand threshold to some secondary current value level and DATC (Demand Ammeter Time Constant) to a value from 5 to 60 minutes (e.g., **NDEM** = 4.50 and **DATC** = 15).
  2. Using the METER RD command, reset demand ammeters to zero.
  3. Note the time and apply a constant current to one phase. The current should be a factor of  $10/9 = 1.11$  times greater than the **NDEM** setting (constant current =  $1.11 \times 4.50 \text{ A} = 5.00 \text{ A}$ ). See Demand Ammeter in Section 2: SPECIFICATIONS for background on the 1.11 factor.

**Note:** With current applied to only one phase (e.g.,  $I_A = 5 \text{ A}$ ,  $I_B = I_C = 0$ ), the following zero-sequence current results:

$$\begin{aligned}
 I_0 &= \frac{1}{3} [I_A + I_B + I_C] \\
 &= \frac{1}{3} [5 \text{ A } \angle 0^\circ + 0 \text{ A } \angle 0^\circ + 0 \text{ A } \angle 0^\circ] \\
 &= 1.67 \text{ A } \angle 0^\circ
 \end{aligned}$$

The residual demand threshold element responds to  $3xI_0$  current. Thus, for this test all demand threshold elements see 5 A.

4. If the current remains constant at 5.00 A, the programmable output contact assigned to the **NDEM** element asserts 15 minutes after you apply current when **DATC** = 15.
5. Repeat these tests for the phase demand threshold alarm **PDEM**.

## RECLOSING RELAY TESTS SETUP

**Purpose:** Make settings for subsequent reclosing relay tests.

**Note:** These tests should be performed using a circuit breaker simulator to simulate the action of the circuit breaker auxiliary contacts. A simple latching relay works well as a circuit breaker simulator.

Connect the SEL-251D-1 Relay TRIP and CLOSE output contacts to the circuit breaker simulator to trip and close the simulator. Connect the simulator output to a relay input assigned to the circuit breaker status function (IN5 = 52A in the following example).

**Method:** 1. Using the SET n command (n is the active setting group), enter the following settings:

```

.
.
.
79OI1    = 60          open interval times (cycles)
79OI2    = 600
79OI3    = 900
79OI4    = 0          no fourth open interval

79RST    = 1800       reset interval time (cycles)
M79SH    = 01010

.
.
.
50L      = 4.00       amps, secondary

.
.
.
A1(1234) = 79RS       reset state
A2(1234) = 79CY       reclose cycle state

.
.
.
A3(1346) = 79LO       lockout state
A4(2346) = 79SH       shot "bit"; asserts per M79SH setting
TR(1246) = 50L        programmable trip conditions
RC(1246) = NA         no reclose cancel conditions

.
.
.
SEQ(1)   = NA         no sequence coordination
ETC(1)   = NA         no externally torque controlled
                        overcurrent elements
ITC(1)   = NA         no internally torque controlled
                        phase overcurrent elements

```

The setting entry NA (not applicable) leaves the designated variable blank when the settings are shown.

- Using the SET G command (G signifies the global setting group: settings common to all groups), enter additional example settings:

```
.  
. .  
. .  
TDUR = 4          trip duration timer (cycles)  
. .  
. .  
IN3  = RE        reclose enable  
IN4  = DC        direct close  
IN5  = 52A       circuit breaker auxiliary
```

The choice of inputs IN3, IN4, and IN5 is for demonstration purposes only.

- After the settings are made, energize IN3 (IN3 = RE) to enable the reclosing relay.

Note that if IN3 is de-energized, the reclosing relay goes to lockout. The relay illuminates the front panel LO (lockout) LED and asserts the A3 output contact (A3 = **79LO**).

- Note that the front panel RS (reset), CY (reclose cycle), and LO (lockout) LEDs follow the **79RS**, **79CY**, and **79LO** Relay Word bits, respectively.

## RECLOSING RELAY RESET INTERVAL TIMER TEST

Purpose: Verify the reclosing relay reset interval timer accuracy.

- Method:
- Enter the settings in the preceding RECLOSING RELAY TESTS SETUP if you haven't already.
  - Open the circuit breaker simulator manually or via the OPEN command. With the circuit breaker simulator open, IN5 is de-energized (IN5 = 52A), the front panel LO (lockout) LED is illuminated, and the A3 output contact is asserted (A3 = **79LO**).
  - Connect the circuit breaker simulator output to an external timer. When the circuit breaker simulator output is asserted (indicating that the circuit breaker has closed), the external timer starts.
  - Connect the A1 output contact to stop the same external timer. The external timer should stop when the A1 output contact asserts (A1 = **79RS**), indicating

that the reclosing relay is in the reset state. When the circuit breaker remains closed for the duration of the reset interval time ( $79RST = 1800$  cycles), the reclosing relay goes into the reset state.

5. Execute the CLOSE Command or energize the IN4 input ( $IN4 = DC$ ; direct close) to cause CLOSE output contact assertion. When the circuit breaker simulator output asserts ( $IN5 = 52A$  energized), the external and reset interval timers start. The front panel LO (lockout) LED remains lit and the A3 output contact is still asserted ( $A3 = 79LO$ ).

When the reset interval timer expires, the reclosing relay is in the reset state, the A1 output contact asserts ( $A1 = 79RS$ ), and the A3 output contact deasserts ( $A3 = 79LO$ ). The front panel LO (lockout) LED turns off and the RS (reset) LED is illuminated.

A1 output contact assertion stops the external timer. Compare the external timer reading to the reset interval time setting (in this example  $79RST = 1800$  cycles).

## RECLOSING RELAY OPEN INTERVAL TIMER TEST

Purpose: Verify the reclosing relay open interval timer accuracy.

Method: 1. Enter the settings in RECLOSING RELAY TESTS SETUP if you haven't already.

In this example there are only three set open interval times:

$79OI1 = 60$	open interval times (cycles)
$79OI2 = 600$	
$79OI3 = 900$	
$79OI4 = 0$	no fourth open interval

2. Execute the CLOSE Command or energize the IN4 input ( $IN4 = DC$ ; direct close) to cause the relay to assert the CLOSE output contact. With the circuit breaker simulator closed, IN5 is energized ( $IN5 = 52A$ ) and the front panel RS (reset) LED illuminates after the reset interval timer expires ( $79RST = 1800$  cycles). The A1 output contact asserts ( $A1 = 79RS$ ).
3. If you just performed the preceding RECLOSING RELAY RESET INTERVAL TIMER TEST:

The circuit breaker simulator is already closed and the reclosing relay is in the reset state. The front panel RS (reset) LED is illuminated and the A1 output contact is asserted ( $A1 = 79RS$ ).



Detach the connections to the external timer and reset the timer.

4. Connect the circuit breaker simulator output and a relay TRIP output contact to an external timer so that when the simulator output **and** relay TRIP output contact deassert, the external timer starts. Deassertion of both outputs indicates that the circuit breaker is open and the TRIP condition is gone. If any open interval times remain in the reclosing cycle, the recloser open interval timer also starts.
5. Connect the CLOSE output contact to the same external timer so it stops when the CLOSE output contact asserts. CLOSE output contact assertion indicates that the open interval timer has expired on a particular open interval time period and the relay subsequently asserted the CLOSE output contact.
6. Apply 5 amps of current to only one phase of the relay. The TRIP output contacts immediately assert (5 A > 50L = 4.00 A; TR = 50L) and the circuit breaker simulator trips open (IN5 = 52A is de-energized).
7. Turn off the current and the TRIP output contact deasserts. Then the external and reclosing relay open interval timers start.

After the open interval timer expires, the CLOSE output contact asserts. This stops the external timer and closes the circuit breaker simulator (IN5 = 52A is energized).

8. Record the time on the external timer and reset it. With the circuit breaker simulator closed, the reclosing relay reset interval timer runs.

The reset interval timer is set for 1800 cycles, so to check the next open interval timer, reapply 5 amps of current to only one phase of the relay before the reset interval expires. Repeat the sequence starting at Number 6.

9. Compare the recorded times to the respective open interval times you monitored. You should expect consecutive open intervals of 60, 600, and 900 cycles. The relay should go to lockout after the fourth trip.

## RECLOSING RELAY STATES TEST

Purpose: Verify reclosing relay states (**79RS**, **79CY**, **79LO**).

Method: 1. Enter the settings in RECLOSING RELAY TESTS SETUP if you haven't already.

You can observe the reclosing relay states while performing the preceding RECLOSING RELAY OPEN INTERVAL TIMING TEST.

2. When you first trip the circuit breaker simulator while in the reset state, the front panel RS (reset) LED extinguishes and the A1 output contact deasserts

(A1 = **79RS**). The reclosing relay is no longer in the reset state. The front panel CY (reclose cycle) LED illuminates, the A2 output contact asserts (A2 = **79CY**), and the reclosing relay is in the reclose cycle state. The reclosing relay remains in the reclose cycle state until one of the following occurs:

The circuit breaker remains closed throughout the reset interval time (79RST = 1800 cycles) so the reclosing relay goes to the reset state. The front panel RS (reset) LED illuminates, the A1 output contact asserts (A1 = **79RS**), and the A2 output contact deasserts (A2 = **79CY**).

or

All open intervals are exhausted and the circuit breaker remains open, so the reclosing relay goes to the lockout state. The front panel LO (lockout) LED illuminates, the A3 output contact asserts (A3 = **79LO**), and the A2 output contact deasserts (A2 = **79CY**).

## RECLOSING RELAY SHOT BIT TEST

**Purpose:** Verify the operation of the reclosing relay shot bit (**79SH**) according to the **M79SH** setting.

**Method:** 1. Enter the settings in **RECLOSING RELAY TESTS SETUP** if you haven't already.

The **79SH** Relay Word bit monitors any desired state of the shot counter. In this example, it is assigned to the A4 output contact (A4 = **79SH**).

This test does not require an external timer.

2. Execute the **CLOSE** command or energize the IN4 input (IN4 = DC; direct close) to cause **CLOSE** output contact assertion. With the circuit breaker simulator closed, IN5 is energized (IN5 = 52A) and the front panel RS (reset) LED illuminates after the reset interval timer expires (79RST = 1800 cycles). The A1 output contact asserts (A1 = **79RS**).
3. You can test the reclosing relay shot bit **79SH** using **RECLOSING RELAY OPEN INTERVAL TIMER TEST** Steps 6 through 8 without monitoring open interval times.

The number of reclosing shots (automatic reclosures) depends on the number of set open interval times. In this example there are three open intervals, so there are three shots. Every time the open interval timer expires, the shot

counter is incremented and an automatic reclosure is initiated (CLOSE output contact is asserted).

When the reclosing relay is in the reset state, shot = 0. The front panel RS (reset) LED is illuminated and the A1 output contact is asserted (A1 = **79RS**).

**79SH** asserts according to the M79SH setting. M79SH can be set for any combination of shots 0, 1, 2, 3, and 4. As previously mentioned, the number of shots depends on the number of set open interval times; this example uses three set open interval times. M79SH is set for only shot = 1 and shot = 3:

$$M79SH = 01010$$

Thus, **79SH** will assert only when shot = 1 or shot = 3.

The shot = 4 position in the M79SH setting (right most position) is not applicable in this example because there are no more than three shots.

4. Use the procedure in RECLOSING RELAY OPEN INTERVAL TIMER TEST steps 6 through 8. After the first open interval expires, the shot counter increments (shot counter increments from shot = 0 to shot = 1) and the CLOSE output contact is then asserted. Because of the M79SH setting (M79SH = 01010), the A4 output contact also asserts (A4 = **79SH**). The shot counter remains at shot = 1 and the A4 output contact remains asserted until:

The circuit breaker remains closed throughout reset interval time (79RST = 1800 cycles), so the reclosing relay goes to the reset state. The front panel RS (reset) LED illuminates, the A1 output contact asserts (A1 = **79RS**), the A2 output contact deasserts (A2 = **79CY**), the shot counter reverts back to shot = 0, and the A4 output contact deasserts (A4 = **79SH**).

or

Current is reapplied to the relay and trips the circuit breaker simulator again before the reset interval timer expires. The shot counter is incremented to shot = 2 and the A4 output contact deasserts (A4 = **79SH**). The A2 output contact remains asserted (A2 = **79CY**)

If you follow RECLOSING RELAY OPEN INTERVAL TIMER TEST steps 6 through 8, the relay trips again before the reset interval expires. The shot counter is then incremented to the next shot.

5. If you repeat these steps, the reclosing relay shot counter will increment until shot = 3. Because of the M79SH setting (M79SH = 01010), the A4 output contact will assert again for shot = 3 (A4 = 79SH).

The reclosing relay will go to lockout on the next trip because shot = 3 is the last shot. The front panel LO (lockout) LED illuminates, the A3 output contact asserts (A3 = 79LO) and the A2 output contact deasserts (A2 = 79CY). The shot counter remains at shot = 3 (last shot) and the A4 output contact remains asserted (A4 = 79SH).

## RECLOSING RELAY SEQUENCE COORDINATION TEST

**Purpose:** Verify the operation of the reclosing relay sequence coordination feature.

**Method:** 1. Enter the settings in RECLOSING RELAY TESTS SETUP if you haven't already. Make the following changes to these settings:

.		
.		
.		
TR(1246)	= NA	no programmable trip conditions
.		
.		
SEQ(1)	= 50L	sequence coordination control condition

The 79SH Relay Word bit monitors any desired state of the shot counter. In this example, it is assigned to the A4 output contact (A4 = 79SH).

This test does not require an external timer.

2. Execute the CLOSE command or energize the IN4 input (IN4 = DC; direct close) to cause CLOSE output contact assertion. With the circuit breaker simulator closed, IN5 is energized (IN5 = 52A) and the front panel RS (reset) LED illuminates after the reset interval timer expires (79RST = 1800 cycles). The A1 output contact asserts (A1 = 79RS) and shot = 0.
3. You can test the reclosing relay sequence coordination feature using the same procedure in RECLOSING RELAY OPEN INTERVAL TIMER TEST steps 6 through 8 without monitoring open interval times. Since no overcurrent trip condition is given (TR = 0), the relay does not trip when you apply current. It remains in the reset state with the circuit breaker closed.

However, SEQ = 50L, so the shot counter is incremented every time the circuit breaker is closed (IN5 = 52A is asserted), you apply and turn off current above the 50L level (4.00 A), and no TRIP output contact asserts.

Every time the shot counter is incremented by SEQ pickup and dropout, the reset interval timer is reinitialized and starts timing. The reclosing relay remains in the reset state (A1 = **79RS** remains asserted).

In application, sequence coordination advances the shot counter, keeping the SEL-251D-1 Relay in step with line reclosers (see Multiple Shot Reclosing Relay in Section 2: SPECIFICATIONS). If the reset interval timer expires before current rises above and falls below the 50L level again, the shot counter resets to shot = 0.

The number of reclosing shots (automatic reclosures) depends on the number of set open interval times. In this example there are three open intervals, so there are three shots.

**79SH** asserts according to the M79SH setting. M79SH can be set for any combination of shots 0, 1, 2, 3, and 4. As previously mentioned, the number of shots depends on the number of set open interval times; this example uses three set open interval times. M79SH is set for shot = 1 and shot = 3:

$$M79SH = 01010$$

Thus, **79SH** will assert only when shot = 1 or shot = 3.

The shot = 4 position in the M79SH setting (right most position) is not applicable in this example because there are only three shots.

The A4 output contact is used to monitor shot counter increments (A4 = **79SH**).

4. Follow the procedure in RECLOSING RELAY OPEN INTERVAL TIMER TEST steps 6 through 8 (remember that the relay will not trip). When the applied current is removed, the shot counter increments from shot = 0 to shot = 1 and the reset interval timer is reinitialized. Because of the M79SH setting (M79SH = 01010), the A4 output contact also asserts (A4 = **79SH**). The shot counter remains at shot = 1 and the A4 output contact remains asserted until:

The circuit breaker remains closed throughout reset interval time (79RST = 1800 cycles), the shot counter reverts back to shot = 0, and the A4 output contact deasserts (A4 = **79SH**). The front panel RS (reset) LED remains illuminated and the A1 output contact remains asserted (A1 = **79RS**).

or

Current is reapplied to the relay and taken away before the reset interval timer expires. The shot counter is then incremented to shot = 2 and the A4 output contact deasserts (A4 = **79SH**). The front panel RS (reset) LED remains

illuminated and the A1 output contact remains asserted (A1 = 79RS).

If you complete RECLOSING RELAY OPEN INTERVAL TIMER TEST steps 6 through 8 you apply current to the relay and remove it before the reset interval expires. The shot counter is then incremented to the next shot.

5. If you repeat these steps, the reclosing relay shot counter will increment until shot = 3. Because of the M79SH setting (M79SH = 01010), the A4 output contact asserts again for shot = 3 (A4 = 79SH). The front panel RS (reset) LED remains illuminated and the A1 output contact remains asserted (A1 = 79RS).

The shot counter remains at shot = 3 if you reapply current to the relay and remove it before the reset interval expires, because shot = 3 is the last shot. The A4 output contact remains asserted (A4 = 79SH). The front panel RS (reset) LED remains illuminated and the A1 output contact remains asserted (A1 = 79RS).

During this entire sequence coordination test, the reclosing relay remained in the reset state. The front panel RS (reset) LED remained illuminated and the A1 output contact was asserted (A1 = 79RS), even though the shot counter was being incremented and the reset interval timer reinitialized. The reset interval timer was only used to bring the shot counter back to shot = 0 after a time equal to the reset interval.

## CLOSE FAILURE TIMER TEST

Purpose: Verify the operating time of the close failure timer.

- Method: 1. Using the SET n command (n is the active setting group), enter the following example setting:

```
.  
. .  
. .  
A4(2346) = CF           close failure condition  
. .  
. .  
. .
```

2. Using the SET G command (G signifies the global setting group: settings common to all groups), enter these settings:

```
.
```

CFT	= 120	close failure time (cycles)
IN4	= DC	direct close
IN5	= 52A	circuit breaker auxiliary

The choice of inputs IN4 and IN5 is for demonstration purposes only.

Connect the CLOSE output contact to an external timer so the timer starts upon CLOSE output contact assertion. The close failure timer in the relay also starts at CLOSE output contact assertion.

The CLOSE output contact remains asserted until the close failure timer expires or the circuit breaker auxiliary contact input to the relay (IN5 = 52A) is energized (circuit breaker successfully closed). In this test, no circuit breaker simulator is connected to either the IN5 input (IN5 = 52A) or the CLOSE output contact. IN5 remains de-energized and the relay considers that the circuit breaker is open.

Connect the A4 output contact to the same external timer to stop the timer when the A4 output contact asserts. A4 contact assertion indicates that the relay failed to close the circuit breaker within the time allotted by the CFT setting; CFT = 120 cycles; A4 = CF, close failure condition.

Assert the relay CLOSE output contact using the CLOSE Command or by energizing the IN4 input (IN4 = DC) function. The external and close failure timers start. Input IN5 must remain de-energized (IN5 = 52A).

When the close failure timer expires, close failure condition CF asserts for 60 cycles and the A4 output contact asserts (A4 = CF). A4 output contact assertion stops the external timer. The CLOSE output contact deasserts when the CF bit asserts and the A4 output contact deasserts 60 cycles after asserting. Compare the external timer reading to the close failure time setting (in this example CFT = 120 cycles).

## TRIP FAILURE TIMER TEST

Purpose: Verify the operating time of the trip failure timer.

Method: 1. Using the SET n command (n is the active setting group), program an element (e.g., 50L, phase overcurrent pickup) for tripping via the programmable tripping variable TR:

close TRIP output contacts = TR + ...

**50L** should not be internally or externally torque controlled (via ITC and ETC). Enter the following example settings:

```
.  
. .  
50L      = 4.00      amps secondary  
. .  
A4(2346) = TF      trip failure condition  
TR(1246) = 50L  
. .  
ETC(1)   = NA  
ITC(1)   = NA
```

The setting entry NA (not applicable) leaves the designated variable blank [e.g., ETC= ].

- Using the SET G command (G signifies the global setting group - settings common to all setting groups), enter the example settings:

```
.  
. .  
TDUR     = 5        trip duration time (cycles)  
TFT      = 30      trip failure time (cycles)  
. . .
```

Connect a TRIP output contact to an external timer so that TRIP output contact assertion starts the external timer. The trip failure timer in the relay also starts when the TRIP output contact asserts.

The TRIP output contact remains asserted until the trip duration timer (TDUR) expires and all programmable trip conditions (TR) go away. Additionally, all overcurrent element pickups have to drop out or TARGET RESET must be pushed to unlatch the TRIP output contact.

Connect the A4 output contact to the same external timer so that it stops timing when A4 asserts. This indicates that the relay has failed to trip the circuit breaker and interrupt the fault current within the time allotted by the TFT setting (TFT = 30 cycles; A4 = **TF**, trip failure condition).



Apply 5 amps of current to one phase of the relay. The TRIP output contacts will immediately assert ( $5\text{ A} > 50\text{L} = 4.00\text{ A}$ ). The external and trip failure timers start immediately.

When the trip failure timer expires, trip failure condition bit **TF** and the A4 output contact assert ( $A4 = \text{TF}$ ). A4 output contact assertion stops the external timer. Compare the external timer reading to the trip failure time setting ( $\text{TFT} = 30$  cycles in this example). The **TF** bit deasserts 60 cycles after you turn the current off.

## INPUT CIRCUITS TEST

**Purpose:** Verify that logic inputs assert when you apply control voltage across respective terminal pairs.

- Method :**
1. Set the target LEDs to display the contact inputs by typing **TAR 7 <ENTER>**. The front panel LEDs should now follow contact inputs.
  2. Apply control voltage to each input and make sure the corresponding target LED turns on. Energizing the DT and ET inputs should trigger an event report. Table 7.3 lists contact inputs and terminal numbers.

**Table 7.3: Contact Inputs and Terminal Numbers**

IN1	17, 18
IN2	19, 20
IN3	21, 22
IN4	23, 24
IN5	25, 26
IN6	27, 28

## SERIAL PORTS TEST

**Purpose:** Verify operation of serial Port 1.

**Method :** The initial checkout procedure assumes you connected a terminal to Port 2F on the relay front panel. Set the baud rate of Port 1 to match that of Port 2 and switch your terminal from Port 2F to Port 1. Be sure you can communicate through this port.

## IRIG-B TIME CODE INPUT TEST

**Purpose:** Verify operation of the IRIG-B clock input port.

- Method:**
1. Connect a source of demodulated IRIG-B time code to the relay Auxiliary Port in series with a resistor to monitor the current. Adjust the source to obtain an "ON" current of about 10 mA.
  2. Execute the IRIG command. Make sure the relay clock displays the correct date and time.

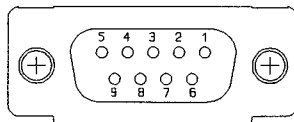
**Note:** A recording of the IRIG-B signal passed through a simple demodulator provides a convenient, inexpensive test of the IRIG-B port. Please contact the factory for further details.

## POWER SUPPLY VOLTAGES TEST

**Purpose:** Verify that correct output voltages are presented to Port 1, Port 2R, and the auxiliary port. These voltages are required by external devices including a dc powered modem or the SEL-DTA and SEL-RD units.

- Method:**
1. Execute the STATUS command and inspect the voltage readings for the +5 and  $\pm 15$  volt supplies.
  2. At the Auxiliary Port, use a voltmeter to read the +5 and  $\pm 12$  volt outputs. The 12 volt outputs are derived from the 15 volt supplies using three-terminal regulators. The following pins are the read points:

Pin 5:	Ground
Pin 9:	Ground
Pin 1:	+5 Vdc
Pin 4:	+12 Vdc
Pin 6:	-12 Vdc



(female chassis connector, as viewed from outside panel)

**Figure 7.5: 9-Pin Connector Pin Number Convention**

3. Compare the +5 volt readings from the status report and voltmeter. The voltage difference should be less than 50 mV, and both readings should be within 0.15 volts of five volts.

The 12-volt supplies should be within 0.5 volts of their nominal values.

## RELAY CALIBRATION

The SEL-251D-1 Relay is factory calibrated to a very high degree of accuracy. If you suspect that the relay is out of calibration, please contact the factory. We can provide instructions for returning the relay for factory recalibration.

## TROUBLESHOOTING

### Inspection Procedure

Complete the following procedure before disturbing the system. After you finish the inspection, proceed to the Troubleshooting Table.

1. Measure and record control power voltage at terminals 44 and 45.
2. Check to see that the power is on, but do not turn system off if it is on.
3. Measure and record the voltage at all control inputs.
4. Measure and record the state of all output relays.
5. Inspect the cabling to the serial communications ports and be sure a communications device is connected to at least one communications port.

### Troubleshooting Table

#### **All Front Panel LEDs Dark**

1. Power is off.
2. Blown power supply fuse.
3. Input power not present.

4. Self-test failure.
5. Target command improperly set.

**Note:** For 1, 2, 3, and 4 the ALARM relay contacts should be closed.

#### **System Does Not Respond to Commands**

1. Communications device not connected to system.
2. Relay or communications device at incorrect baud rate or other communication parameter incompatibility, including cabling error.
3. System is processing event record. Wait several seconds.
4. System is attempting to transmit information, but cannot due to handshake line conflict. Check communications cabling.
5. System is in the XOFF state, halting communications. Type **<CTRL>Q** to put system in XON state.

#### **Tripping Output Relay Remains Closed Following Fault**

1. Contact inputs improperly wired.
2. Output relay contacts burned closed.

#### **No Prompting Message Issued to Terminal upon Power-Up**

1. Terminal not connected to system.
2. Wrong baud rate.
3. Terminal improperly connected to system.
4. Other port designated AUTO in the relay settings.
5. Port timeout interval set to a value other than zero.
6. Board failure.

### **System Does Not Respond to Faults**

1. Relay improperly set. Review your settings with the SHOWSET command.
2. Improper test settings.
3. PT or CT input cable wiring error.
4. Analog input cable between transformer-termination and main board loose or defective.
5. Check self-test status with STATUS command.
6. Check input voltages and currents with METER command and TRIGGER and EVENT sequence.

### **Terminal Displays Meaningless Characters**

1. Baud rate set incorrectly. Check terminal configuration. See Section 3: COMMUNICATIONS.

### **Self-Test Failure: +5 Volts**

1. Power supply +5 volt output out of tolerance. See STATUS command.
2. A/D converter failure.

### **Self-Test Failure: +15 Volts**

1. Power supply +15 volt output out of tolerance. See STATUS command.
2. A/D converter failure.

### **Self-Test Failure: -15 Volts**

1. Power supply -15 volt output out of tolerance. See STATUS command.
2. A/D converter failure.

### **Self-Test Failure: Offset**

1. Offset drift. Adjust offsets.
2. A/D converter drift.

**Self-Test Failure: ROM Checksum**

1. EPROM failure. Replace EPROM(s).

**Self-Test Failure: RAM**

1. Static RAM IC failure. Replace RAM(s).

**Self-Test Failure: A/D Converter**

1. A/D converter failure.
2. RAM error not detected by RAM test.

**Alarm Contact Closed**

1. Power is off.
2. Blown power supply fuse.
3. Power supply failure.
4. Improper EPROMs or EPROM failure.
5. Board failure.

## FIRMWARE UPGRADE INSTRUCTIONS

SEL may occasionally offer firmware upgrades to improve the performance of your relay. These instructions explain how to remove the relay drawout assembly to install new firmware.

The modifications require that you power down the relay, remove the relay front panel, pull out the drawout unit, exchange several integrated circuit chips, and reassemble the relay. If you do not wish to perform the modifications yourself, we can assist you. Simply return the relay and integrated circuit chips to us. We will install the new chips and return the unit to you within a few days.

## Upgrade Instructions

1. If the relay is in service, disable its control functions. Turn off control power to the relay. Disconnect all communication cables from the rear panel of the relay.
2. Remove the relay front panel by unscrewing the five front panel screws. With the front panel removed, you can see the aluminum drawout chassis. The main board is attached to the top of the drawout chassis. The power supply and transformer assembly are attached to the bottom of the relay chassis.
3. Disconnect the power supply and transformer secondary cables from the underside of the drawout assembly.

**Caution:** This procedure requires that you handle electrostatic discharge sensitive components. If your facility is not equipped to work with these components, we recommend that you return the relay to SEL for firmware installation.

4. Remove the drawout assembly by pulling the spacers on the bottom of the drawout chassis. You should be able to remove the assembly with your fingers. If the drawout assembly does not come free, check to make sure all communications cables are disconnected from the relay rear panel. Because steps 5 and six involve handling electrostatic discharge (ESD) sensitive devices and assemblies, perform these steps at an ESD safe work station. This will help prevent possible damage by electrostatic discharge.
5. Note the orientation of the ICs to be replaced. Use a small screwdriver to pry the indicated ICs free from their sockets. Be careful not to bend the IC pins or damage adjacent components.
6. Carefully place the new ICs in the appropriate sockets. Check the orientation of the ICs. Be sure that each IC is in its corresponding socket. Look for IC pins that bent under or did not enter a socket hole.
7. Slide the drawout assembly into the relay chassis. Using your fingers, push the assembly in until the front of the assembly is flush with the front of the relay chassis. Reconnect the power supply and transformer secondary cables to the receivers on the underside of the drawout assembly. Replace the relay front panel.
8. With breaker control disabled, turn relay power on and enter your settings. Execute the STATUS, METER, and TRIGGER commands to ensure that all functions are operational. Set and record your Access Level 1 and 2 passwords and the date and time. The relay is now ready to resume protective functions.

## **FACTORY ASSISTANCE**

If you have any questions regarding the performance, application, or repair of this or any other SEL product, do not hesitate to contact the factory. Our staff is always happy to assist you.

Schweitzer Engineering Laboratories, Inc.

2350 NE Hopkins Court

Pullman, WA 99163-5603

Tel: (509) 332-1890

FAX: (509) 332-7990



**APPENDICES  
TABLE OF CONTENTS**

---

Appendix A - Firmware Versions .....	Appendix A-1
Appendix B - Internal Diagram .....	Appendix B-1
Appendix C - Onebus: Program to Compute Test Set Settings for Testing Distance Relays .....	Appendix C-1



## APPENDIX A: FIRMWARE VERSIONS

The firmware versions are listed in chronological order (most recent firmware at top).

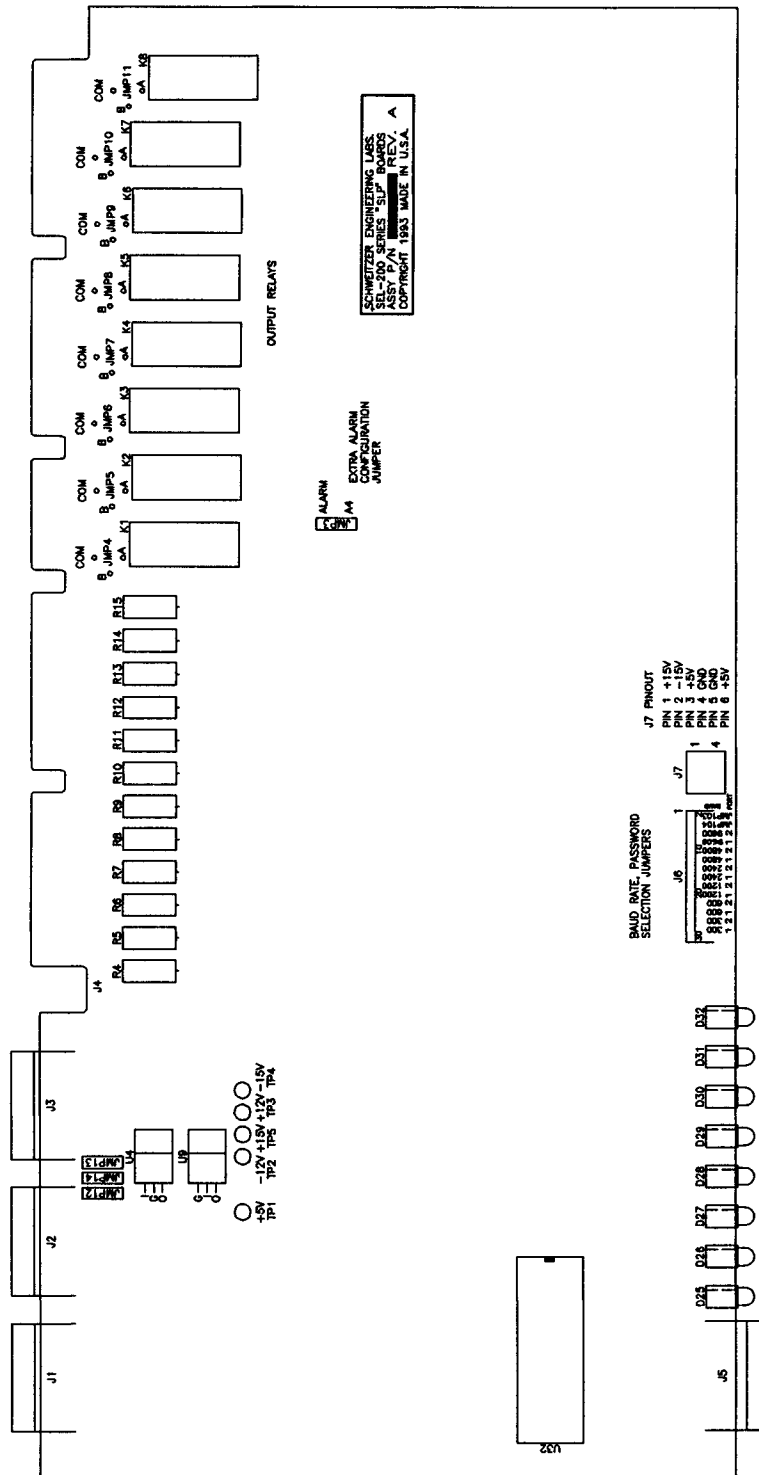
Firmware Part/Revision No.	Description of Firmware
SEL-251D-1-R410	This firmware differs from the previous versions as follows: – Initialized analog gain on unused channel.
SEL-251D-1-R409	This firmware differs from the previous versions as follows: – INST target is now independent of phase targets.
SEL-251D-1-R408	This firmware differs from the previous versions as follows: – Debounce all control inputs. – Extinguish RS, CY, and LO LEDs when relay is disabled. – Enhance SEL-2020 compatibility.
SEL-251D-1-R407	This firmware differs from the previous versions as follows: – Changed the RINGS setting prompt to “RINGS 1 - 30.” – Added FOP Fast Operate enable input assignment.
SEL-251D-1-R406	This firmware differs from the previous versions as follows: – Added high-side blown-fuse logic with new 27C setting option. – Improved operation of Fast Meter and Fast Operate.
SEL-251D-1-R404	This firmware differs from the previous versions as follows: – Added Fast Operate.
SEL-251D-1-R403	
SEL-251D-1-R402	This firmware differs from the previous versions as follows: – Added short-time inverse curve.
SEL-251D-1-R401	
SEL-251D-1-R400	– 60 Hz, 5 A includes extended Fast Meter.

To find the firmware revision number in your relay, obtain an event report (which identifies the firmware) using the **EVENT** command. This is an FID number with the Part/Revision number in bold:

**FID=SEL-251D-1-R403-656rp1ggd-D940405**

For a detailed explanation of the Firmware Identification Number (FID) refer to Section 4: **EVENT REPORTING**.

# APPENDIX B - INTERNAL DIAGRAM



SEL-200 Series (Shallow) Main Board Troubleshooting Test Points and Jumper Locations



## APPENDIX C - ONEBUS: PROGRAM TO COMPUTE TEST SET SETTINGS FOR TESTING DISTANCE RELAYS

---

The BASIC program in this note determines voltages and currents which would appear on distance relay terminals for ground and phase faults on a radial system with source impedance at the same angle as line impedance. It is useful in determining test voltage and current settings for SEL distance relays and fault locating equipment.

The program was initially designed to run on a TRS-80 Model 100 briefcase computer but may be installed on virtually any personal computer or laptop.

The program first prompts you for the positive- and zero-sequence impedances of the transmission line. Enter the data in secondary ohms for the entire length of the protected line.

Next, you may enter fault resistance, which is used in the ground-fault computations.

Enter source impedance as a per-unit value with a base of the previously-entered transmission line data. For example, if the radial system has a source impedance of about ten percent of the entered line impedance, enter 0.1 for the per-unit distance from the source to the bus.

Specify the distance from the bus to the fault as a fraction of the total line length. To obtain the voltages and currents for a fault one-half the way down the line from the bus, enter 0.5 for the distance from the bus to the fault.

After you enter this data, the program begins computations. The display then shows voltages and currents for both an AG and BC fault. These data can be entered into any active test source.

The bottom line of the display offers you a choice of entering new impedance data (I), changing the distance from the source to the bus (B), specifying a new fault location (F), or quitting (Q).

```

1  REM SCHWEITZER ENGINEERING LABORATORIES, INC.
2  REM 2350 NE Hopkins Court
3  REM Pullman, WA 99163-5603
4  REM
10 REM COMPUTE DOBLE SETTINGS FOR A ONE-BUS SYSTEM
20 REM HOMOGENEOUS SYSTEM
30 REM SOURCE VOLTS= 67.L-N
40 REM
50 REM ENTER IMPEDANCES FOR 100% OF LINE
60 INPUT "ENTER Z1: R,X";R1,S1
70 INPUT "ENTER Z0: R,X";R0,S0
75 INPUT "ENTER RF FOR GND FLT";RF
80 REM
90 REM ENTER BUS LOC. FROM SOURCE
100 INPUT "DIST SOURCE TO BUS (PU OF LINE)";S
120 INPUT "DIST BUS TO FAULT (PU OF LINE)";F
130 REM
140 REM PHASE A TO GROUND
150 REM COMPUTE POS SEQ CURRENT
160 X = R0+2*R1: Y = S0+2*S1
170 R3 = R1-R0: S3 = S1-S0
180 AR=1/(S+F): AI=0
190 BR=X : BI=Y
195 BR=BR+3*RF/(S+F)
200 GOSUB 2000
210 I = RR : J = RI
220 IA = 3*67*I: JA=3*67*J
225 IB=0:JB=0:IC=0:JC=0
230 AR=X:AI=Y:BR=I:BI=J
232 GOSUB 1000
234 UA=67*(1-S*RR):VA=67*(-S*RI)
240 AR=R3 :AI=S3
250 BR=I :BI=J
260 GOSUB 1000
270 TR=S*RR :TS=S*RI
280 UB=67*(-0.5+TR)
290 VB=67*(-SQR(3)/2+TS)
300 UC=67*(-0.5+TR)
310 VC=67*(SQR(3)/2+TS)
315 FF$="A-G"
320 GOSUB 4041
500 REM B-C FAULT
510 AR=1: AI=0
520 BR=2*R1*(S+F):BI=2*S1*(S+F)
530 GOSUB 2000
540 I=RR:J=RI
550 IA=0:JA=0
560 AR=I:AI=J:BR=0:BI=-67*SQR(3)
570 GOSUB 1000
580 IB=RR:JB=RI:IC=-IB:JC=-JB
590 UA=67:VA=0
600 AR=I:AI=J:BR=S*R1:BI=S*S1
610 GOSUB 1000
620 AR=RR:AI=RI:BR=0:BI=SQR(3)
630 GOSUB 1000

```

```

635 TR=RR:TS=RI
640 UB=67*(-0.5+TR)
650 VB=67*(-SQR(3)/2+TS)
660 UC=67*(-0.5+TR)
670 VC=67*(0.5*SQR(3)-TS)
675 FF$="B-C"
680 GOSUB 4041
900 INPUT "IMP BUS FAULT OR QUIT (I,B,F,Q)";A$
910 IF A$ = "I" THEN GOTO 50
920 IF A$ = "B" THEN GOTO 75
930 IF A$ = "F" THEN GOTO 120 ELSE GOTO 999
999 END
1000 REM MULT SUBROUTINE
1010 REM AR,AI * BR,BI = RR,RI
1020 RR=AR*BR-AI*BI
1030 RI=AI*BR+AR*BI
1040 RETURN
2000 REM DIVISION SUBROUTINE
2010 REM AR,AI / BR,BI = RR,RI
2020 D = BR*BR + BI*BI
2030 RR = AR*BR + AI*BI
2040 RR = RR/D
2050 RI = BR*AI - AR*BI
2060 RI = RI/D
2070 RETURN
3000 REM RECT TO POLAR CONV
3010 REM AR,AI, TO RH, TH
3020 PI = 3.14159265358
3030 IF (AR=0 AND AI=0) THEN RH=0: TH=0: RETURN
3040 IF (AR=0 AND AI>0) THEN RH=AI: TH=90: RETURN
3050 IF (AR=0 AND AI<0) THEN RH=-AI: TH=-90: RETURN
3060 IF (AR>0) THEN TH=(180/PI)*ATN(AI/AR)
3070 IF (AR<0) THEN TH=(180/PI)*ATN(AI/AR)+180
3080 IF TH>180 THEN TH = TH-360
3090 RH=SQR(AR*AR+AI*AI)
3100 RETURN
4041 AR=UA:AI=VA:GOSUB 3000
4042 UA=RH:VA=TH
4043 AR=UB:AI=VB:GOSUB 3000
4044 UB=RH:VB=TH-VA
4045 AR=UC:AI=VC:GOSUB 3000
4046 UC=RH:VC=TH-VA
4047 AR=IA:AI=JA:GOSUB 3000
4048 IA=RH:JA=TH-VA
4049 AR=IB:AI=JB:GOSUB 3000
4050 IB=RH:JB=TH-VA
4055 AR=IC:AI=JC:GOSUB 3000
4060 IC=RH:JC=TH-VA
4061 VA=0
4100 PRINT " VA VB VC IA IB IC"
4130 PRINT USING"###.# ";UA;UB;UC;IA;IB;IC,
4132 PRINT FF$
4140 PRINT USING"#### ";VA;VB;VC;JA;JB;JC
4150 RETURN

```



# SEL-251D-1 RELAY COMMAND SUMMARY

## Access Level 0

ACCESS Answer password prompt (if password protection is enabled) to enter Access Level 1. Third unsuccessful attempt pulses ALARM contacts closed for one second.

## Access Level 1

2ACCESS Answer password prompt (if password protection is enabled) to enter Access Level 2. This command always pulses the ALARM contacts closed for one second.

BREAKER Displays running sum of circuit breaker trips for relay and external trips (circuit breaker trip counters). Also displays running sum of interrupted current in each circuit breaker pole for relay and external trips. Current values are displayed in kA (kiloamperes).

BREAKER R Resets circuit breaker trip counters and interrupted current sums to zero for both relay and external trips. Relay stores reset date and time.

DATE m/d/y Sets or displays date. DAT 4/1/93 sets date to April 1, 1993. IRIG-B time code input overrides existing month and day settings. DATE pulses ALARM contacts when year entered differs from year stored. To display the date only, enter DATE.

EVENT n Shows event record. EVE or EVE 1 shows newest event; EVE 12 shows oldest (n=1, 2, 3,...,11, or 12).

HISTORY Shows DATE, TIME, EVENT, LOCAT (location), SHOT, TARGETS, and CURR (maximum fault current) for the last twelve events.

IRIG Forces immediate attempt to synchronize internal relay clock to time code input.

METER n Displays present phase and residual current values; present real and reactive power values; present line-to-line voltage values. Optional n displays METER data n times.

METER D Displays demand and peak demand values of phase and residual current values and real and reactive power values.

METER RD Resets demand values.

METER RP Resets peak demand values.

QUIT Returns control to Access Level 0; returns target display to Relay Targets.

SHOWSET n Displays settings of setting group n without affecting them (n = 1, 2, 3, 4, 5, or 6).

STATUS Shows self-test status.

TARGET n k Shows data and sets target LEDs as follows (n = 0, 1, 2, . . . 7, or 8):

TAR 0: Front Panel Targets	TAR 1: Relay Word row R1
TAR 2: Relay Word row R2	TAR 3: Relay Word row R3
TAR 4: Relay Word row R4	TAR 5: Relay Word row R5
TAR 6: Relay Word row R6	TAR 7: Input States
TAR 8: Output Contact States	Optional k displays target data k times.

TARGET R Clears targets and returns to TAR 0

TIME h/m/s Sets or displays time. TIM 13/32/00 sets clock to 1:32:00 PM. IRIG-B synchronization overrides this setting. To display the time only, enter TIME.

TRIGGER Triggers and saves an event record (event type is EXT).

## **Access Level 2**

CLOSE Closes circuit breaker, if allowed by jumper setting.

COPY m n Copies setting group m to setting group n (m and n equal any combination of 1, 2, 3, 4, 5, or 6). Clears buffers. If n is the active setting group, the ALARM output contacts pulse closed.

GROUP n Designates the active setting group when no Setting Group Selection Inputs are assigned to inputs or all Setting Group Selection Inputs assigned to inputs are deasserted (n = 1, 2, 3, 4, 5, or 6). The ALARM output contacts pulse closed when the active group changes. GROUP n command execution does not clear the event buffer.

OPEN Opens circuit breaker, if allowed by jumper setting.

PASSWORD Shows or sets passwords. ALARM contacts pulse closed after password entry. PAS 1 OTTER sets Level 1 password to OTTER. PAS 2 TAIL sets Level 2 password to TAIL.

SET n p Initiates setting procedure for setting group n (n = 1, 2, 3, 4, 5, or 6). Option p directs the relay to begin the setting procedure for setting group n at setting p (e.g., if p = 51P, the setting procedure starts at setting 51P, bypassing all settings before 51P). If no optional p is entered, the setting procedure starts at the beginning.

The relay clears event buffers when new settings are stored. If n is the active setting group, the ALARM output contact pulses closed.

SET G p Initiates setting procedure for the global setting group. Option p directs the relay to begin the setting procedure for the global setting group at setting p (e.g., if p = TDUR, the setting procedure starts at setting TDUR, bypassing all settings before TDUR). If optional p is not used, the setting procedure starts at the beginning.

The SET G command pulses ALARM contacts closed and clears event buffers when new settings are stored.

---

**SCHWEITZER ENGINEERING LABORATORIES, INC.**  
 2350 NE Hopkins Court  
 Pullman, WA 99163-5603  
 Tel: (509) 332-1890 Fax: (509) 332-7990

Copyright © SEL 1992, 1993, 1994  
 (All rights reserved)  
 Printed in USA

This product is covered by U.S. Patent No. 5,041,737 and U.S. Patent(s) Pending.

# SEL-251D-1 RELAY COMMAND SUMMARY

## Access Level 0

ACCESS Answer password prompt (if password protection is enabled) to enter Access Level 1. Third unsuccessful attempt pulses ALARM contacts closed for one second.

## Access Level 1

2ACCESS Answer password prompt (if password protection is enabled) to enter Access Level 2. This command always pulses the ALARM contacts closed for one second.

BREAKER Displays running sum of circuit breaker trips for relay and external trips (circuit breaker trip counters). Also displays running sum of interrupted current in each circuit breaker pole for relay and external trips. Current values are displayed in kA (kiloamperes).

BREAKER R Resets circuit breaker trip counters and interrupted current sums to zero for both relay and external trips. Relay stores reset date and time.

DATE m/d/y Sets or displays date. DAT 4/1/93 sets date to April 1, 1993. IRIG-B time code input overrides existing month and day settings. DATE pulses ALARM contacts when year entered differs from year stored. To display the date only, enter DATE.

EVENT n Shows event record. EVE or EVE 1 shows newest event; EVE 12 shows oldest (n=1, 2, 3,...,11, or 12).

HISTORY Shows DATE, TIME, EVENT, LOCAT (location), SHOT, TARGETS, and CURR (maximum fault current) for the last twelve events.

IRIG Forces immediate attempt to synchronize internal relay clock to time code input.

METER n Displays present phase and residual current values; present real and reactive power values; present line-to-line voltage values. Optional n displays METER data n times.

METER D Displays demand and peak demand values of phase and residual current values and real and reactive power values.

METER RD Resets demand values.

METER RP Resets peak demand values.

QUIT Returns control to Access Level 0; returns target display to Relay Targets.

SHOWSET n Displays settings of setting group n without affecting them (n = 1, 2, 3, 4, 5, or 6).

STATUS Shows self-test status.

TARGET n k Shows data and sets target LEDs as follows (n = 0, 1, 2, . . . 7, or 8):

TAR 0: Front Panel Targets	TAR 1: Relay Word row R1
TAR 2: Relay Word row R2	TAR 3: Relay Word row R3
TAR 4: Relay Word row R4	TAR 5: Relay Word row R5
TAR 6: Relay Word row R6	TAR 7: Input States
TAR 8: Output Contact States	Optional k displays target data k times.

TARGET R Clears targets and returns to TAR 0

TIME h/m/s Sets or displays time. TIM 13/32/00 sets clock to 1:32:00 PM. IRIG-B synchronization overrides this setting. To display the time only, enter TIME.

TRIGGER Triggers and saves an event record (event type is EXT).

## **Access Level 2**

CLOSE Closes circuit breaker, if allowed by jumper setting.

COPY m n Copies setting group m to setting group n (m and n equal any combination of 1, 2, 3, 4, 5, or 6). Clears buffers. If n is the active setting group, the ALARM output contacts pulse closed.

GROUP n Designates the active setting group when no Setting Group Selection Inputs are assigned to inputs or all Setting Group Selection Inputs assigned to inputs are deasserted (n = 1, 2, 3, 4, 5, or 6). The ALARM output contacts pulse closed when the active group changes. GROUP n command execution does not clear the event buffer.

OPEN Opens circuit breaker, if allowed by jumper setting.

PASSWORD Shows or sets passwords. ALARM contacts pulse closed after password entry. PAS 1 OTTER sets Level 1 password to OTTER. PAS 2 TAIL sets Level 2 password to TAIL.

SET n p Initiates setting procedure for setting group n (n = 1, 2, 3, 4, 5, or 6). Option p directs the relay to begin the setting procedure for setting group n at setting p (e.g., if p = 51P, the setting procedure starts at setting 51P, bypassing all settings before 51P). If no optional p is entered, the setting procedure starts at the beginning.

The relay clears event buffers when new settings are stored. If n is the active setting group, the ALARM output contact pulses closed.

SET G p Initiates setting procedure for the global setting group. Option p directs the relay to begin the setting procedure for the global setting group at setting p (e.g., if p = TDUR, the setting procedure starts at setting TDUR, bypassing all settings before TDUR). If optional p is not used, the setting procedure starts at the beginning.

The SET G command pulses ALARM contacts closed and clears event buffers when new settings are stored.

---

**SCHWEITZER ENGINEERING LABORATORIES, INC.**  
 2350 NE Hopkins Court  
 Pullman, WA 99163-5603  
 Tel: (509) 332-1890 Fax: (509) 332-7990

Copyright © SEL 1992, 1993, 1994  
 (All rights reserved)  
 Printed in USA

This product is covered by U.S. Patent No. 5,041,737 and U.S. Patent(s) Pending.