

# CONTENTS

SECTION 1 • GENERAL INFORMATION .....	1-1
Description .....	1-1
Specifications .....	1-1
SECTION 2 • FUNCTIONAL DESCRIPTION .....	2-1
Introduction .....	2-1
Theory Of Operation .....	2-2
Input Amplifier .....	2-2
Automatic Gain Controlled Amplifier .....	2-2
Variable Bandpass Ripple Amplifier .....	2-2
Precision Rectifier .....	2-2
Inverse Timer .....	2-2
Relay Driver .....	2-2
Bargraph Display .....	2-3
AVR Ripple Amplifier .....	2-3
Power Supply .....	2-3
SECTION 3 • CONTROLS AND INDICATOR .....	3-1
GENERAL .....	3-1
SECTION 4 • INSTALLATION AND CALIBRATION .....	4-1
Mounting .....	4-1
Interconnection .....	4-1
Calibration - Standard .....	4-1
Initial Adjustments .....	4-1
Start-Up Procedure .....	4-1
Trip Test .....	4-3
Final Checkout .....	4-3
Calibration - With DECS Unit .....	4-3
Initial Adjustments .....	4-3
Start-Up Procedure .....	4-3
Trip Test .....	4-4
Final Checkout .....	4-4
SECTION 5 • MAINTENANCE INFORMATION .....	5-1
Preventative Maintenance .....	5-1
Corrective Maintenance .....	5-1
SECTION 6 • MANUAL CHANGE INFORMATION .....	6-1
Changes .....	6-1

# INSTRUCTION MANUAL

## FOR DIRECTIONAL POWER RELAYS BE1-32R AND BE1-32 O/U

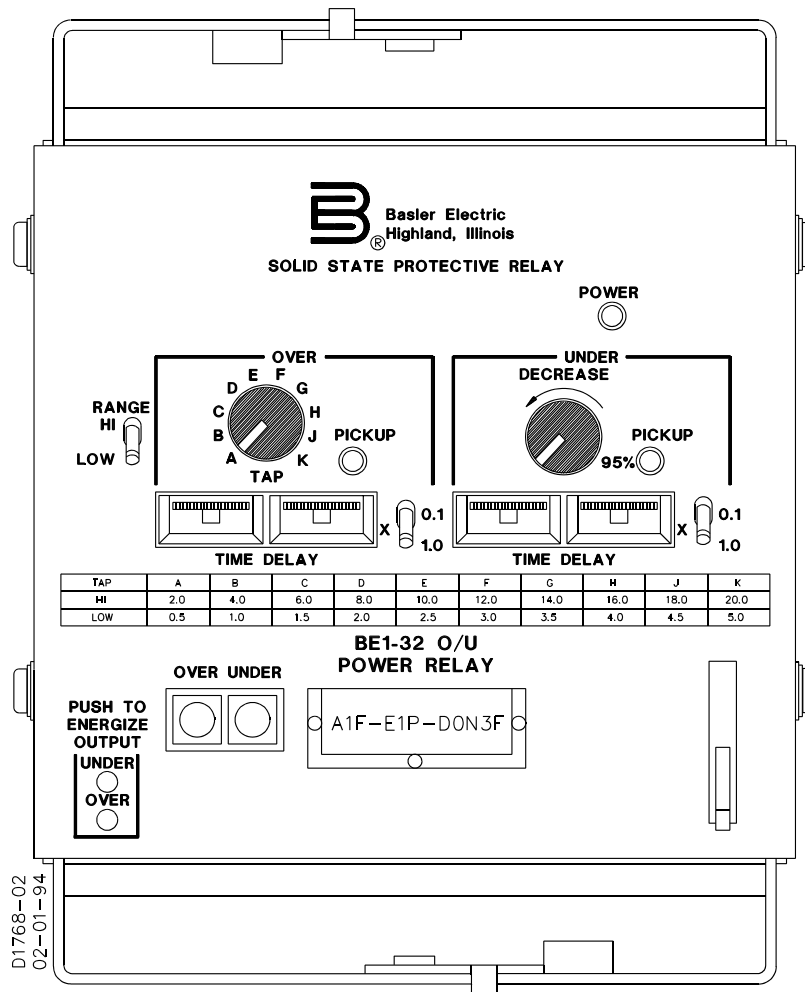

# **B** Basler Electric

Publication Number: 9 1711 00 990  
Revision: J 09/2000

## INTRODUCTION

---

This manual provides information concerning the operation and installation of EDM 200 Exciter Diode Monitor. To accomplish this, the following is provided.

- Specifications
- Functional Description
- Installation and Calibration Information
- Maintenance

**WARNING**  
**TO AVOID PERSONAL INJURY OR EQUIPMENT DAMAGE, ONLY QUALIFIED PERSONNEL SHOULD PERFORM THE PROCEDURES PRESENTED IN THIS MANUAL.**

First Printing: August 1984

Printed in USA

© 1997 – 2000, Basler Electric Co., Highland, IL 62249

June 2000

**CONFIDENTIAL INFORMATION**

OF BASLER ELECTRIC COMPANY, HIGHLAND, IL. IT IS LOANED FOR CONFIDENTIAL USE, SUBJECT TO RETURN ON REQUEST, AND WITH THE MUTUAL UNDERSTANDING THAT IT WILL NOT BE USED IN ANY MANNER DETRIMENTAL TO THE INTEREST OF BASLER ELECTRIC COMPANY.

It is not the intention of this manual to cover all details and variations in equipment, nor does this manual provide data for every possible contingency regarding installation or operation. The availability and design of all features and options are subject to modification without notice. Should further information be required, contact Basler Electric Company, Highland, Illinois.

**BASLER ELECTRIC  
ROUTE 143, BOX 269  
HIGHLAND, IL 62249 USA**

**<http://www.basler.com>, [info@basler.com](mailto:info@basler.com)**

**PHONE 618-654-2341**

**FAX 618-654-2351**

# SECTION 1 • GENERAL INFORMATION

---

## DESCRIPTION

The Basler Model EDM 200 Exciter Diode Monitor is a device added to the exciter field circuit to monitor the output of the brushless exciter power semiconductors. The EDM 200 can detect the failure of a power rectifier in the brushless exciter which fails in either the open or shorted mode. A set of Form C contacts is utilized to provide an alarm indication.

---

## SPECIFICATIONS

Refer to Table 1-1 for the Electrical Specifications and to Table 1-2 for the Physical Specifications of the EDM 200.

*Table 1-1. Electrical Specifications*

<b>Input Power</b>	100-120 Vac, 200-240 Vac, 380-480 Vac, or 528-600 Vac Nominal.
<b>Input Power Burden</b>	10 VA
<b>Field Sensing</b>	0.5 to 7.0 A or 20 to 100 mV signal shunt.
<b>Outputs</b>	Bargraph display for monitoring and calibration.  Form C relay output contacts rated at 10 A @ 120/240 Vac, 10 A @ 24 Vdc, or 0.5 A @ 125 Vac for alarm indication.
<b>Time Delay</b>	Open Diode: Approximately 15 Seconds. Shorted Diode: Approximately 5 Seconds.
<b>Exciter Rectifier Frequency</b>	50 to 400 Hz
<b>Ripple Frequency</b>	150 to 2000 Hz

*Table 1-2. Physical Specifications*

<b>Operating Temperature</b>	-40°C (-40°F) to +70°C (+158°F).
<b>Storage Temperature</b>	-65°C (-85°F) to +85°C (+185°F).
<b>Vibration</b>	Withstands: 5 to 26 Hz at 1.2 G's 27 to 52 Hz at 0.036 inch double amplitude 53 to 1000 Hz at 5.0 G's.
<b>Shock</b>	Withstands up to 15 G's in each of three mutually perpendicular axes.
<b>Weight</b>	3 lbs. 10 oz. (1.65 kg)

# SECTION 2 • FUNCTIONAL DESCRIPTION

## INTRODUCTION

Diode rectifiers mounted on the rotor of a brushless generator or motor fail by either opening or shorting.

If a rectifier shorts, very high current will flow through the associated exciter armature winding thus causing excessive heating and probable failure of the exciter. If a diode opens, the voltage regulator will substantially increase the excitation to maintain the operating level. This constant, high level of excitation could cause a regulator failure.

The Exciter Diode Monitor is able to determine the status of the rotating rectifiers sensing the ripple content of the exciter field current. Refer to Figure 2-1. The waveform shown in Figure 2-1A is the normal ripple with all diodes functional. Figure 2-1B is the waveform with one diode open and Figure 2-1C shows a waveform with one diode shorted.

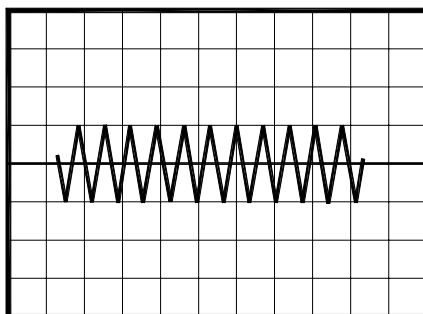

FIGURE A – ALL DIODES NORMAL

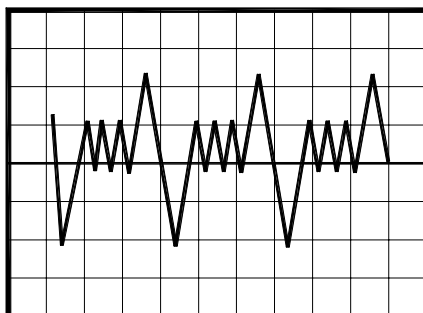

FIGURE B – ONE DIODE OPEN

02717-13  
12-02-97

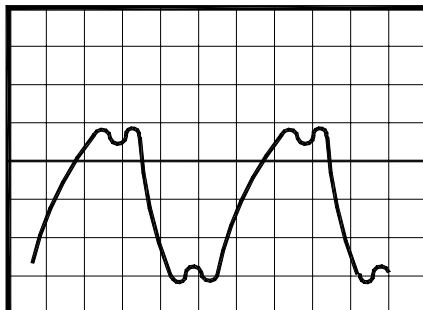

FIGURE C – ONE DIODE SHORTED

*Figure 2-1. Typical Rectifier Diode Waveforms*

## THEORY OF OPERATION (Refer to Figure 2-2)

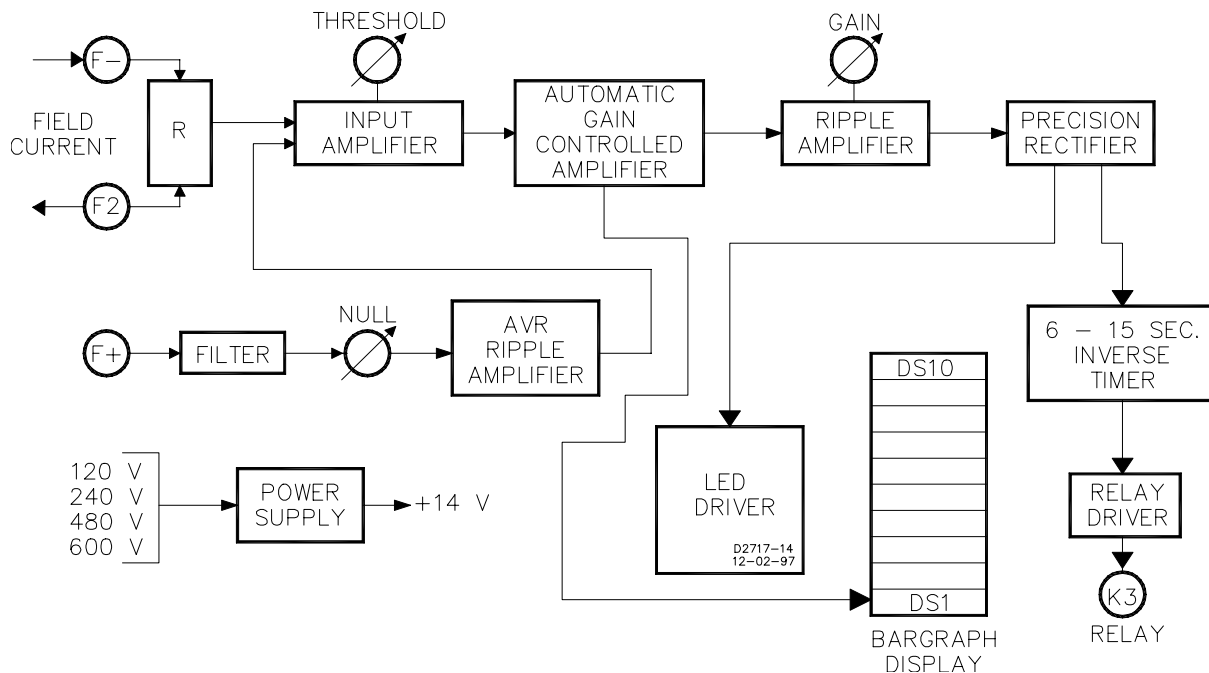

Figure 2-2. Exciter Diode Monitor Block Diagram

### Input Amplifier

Resistor R is connected in series with the negative lead to the exciter field. The small voltage drop across R is amplified by the input amplifier to approximately 1 volt when the generator is unloaded. During various loaded conditions, the amplifier output will increase from 1 volt to about 4 volts.

### Automatic Gain Controlled Amplifier

As the output of the Input Amplifiers varies from one to four volts, the associated ripple content also varies. To prevent the Monitoring Circuits from interpreting the one to four volt change as a diode failure, the Automatic Gain Controlled Amplifier offsets the signal variations so that the Monitoring Circuit monitors the ripple in a constant amplitude signal.

### Variable Bandpass Ripple Amplifier

When all of the rotating diodes are operating normally, the field current ripple is of small amplitude and high frequency. When a diode is faulty, the ripple is large amplitude and low frequency (one-third or one-sixth of normal). Thus, the Ripple Amplifier has a high gain at low frequencies and a low gain at high frequencies. The Amplifier provides adjustment of the high frequency gain to provide compatibility with a wide variety of brushless generators.

### Precision Rectifier

This Rectifier converts the ac output of the Ripple Amplifier to a dc signal.

### Inverse Timer

The dc output of the Precision Rectifier passes through an Inverse Timing Network to provide a prompt tripping for a shorted diode but allows longer delays for an open diode.

### Relay Driver

The Relay Driver is a transistor that controls the Relay (K1) coil voltage.

### Bargraph Display

This ten segment Bargraph style display is used to calibrate and monitor the operation of the Exciter Diode Monitor.

### AVR Ripple Amplifier

Since the AVR output consists of pulses, a strong ripple component consisting of these pulses is present in the field current and make the detection of an open diode difficult. To eliminate the AVR ripple, the AVR voltage at terminal **F+** is passed through a filter, a **NULL** adjustment, and the AVR Ripple Amplifier. The Amplifier output is then used by the Input Amplifier to cancel out the AVR ripple component in the field current.

### Power Supply

The entire Exciter Diode Monitor circuitry operates from a regulated +14 Vdc that is provided by the Transformer-Rectifier type Power Supply. The Relay output will be inhibited and the Bargraph Display may display incorrect information until the input voltage is at least 50% of nominal.



# SECTION 3 • CONTROLS AND INDICATOR

## GENERAL

For the location and description of the Exciter Diode Monitor controls and indicator, refer to Figure 3-1 and Table 3-1.

Table 3-1. Controls and Indicator

Control/Indicator	Function
<b>GAIN Control</b>	This potentiometer controls the setting for the tripping of the alarm and activation of the output relay.
<b>NULL Control</b>	This potentiometer is used to null out the voltage regulator ripple component of the field current.
<b>THRESHOLD Control</b>	This potentiometer sets the threshold to the automatic gain control amplifier output level that just lights the <b>THRESHOLD</b> segment of the bargraph display at no-load.
<b>Bargraph Display</b>	This LED type display will display the condition of the exciter diode current.

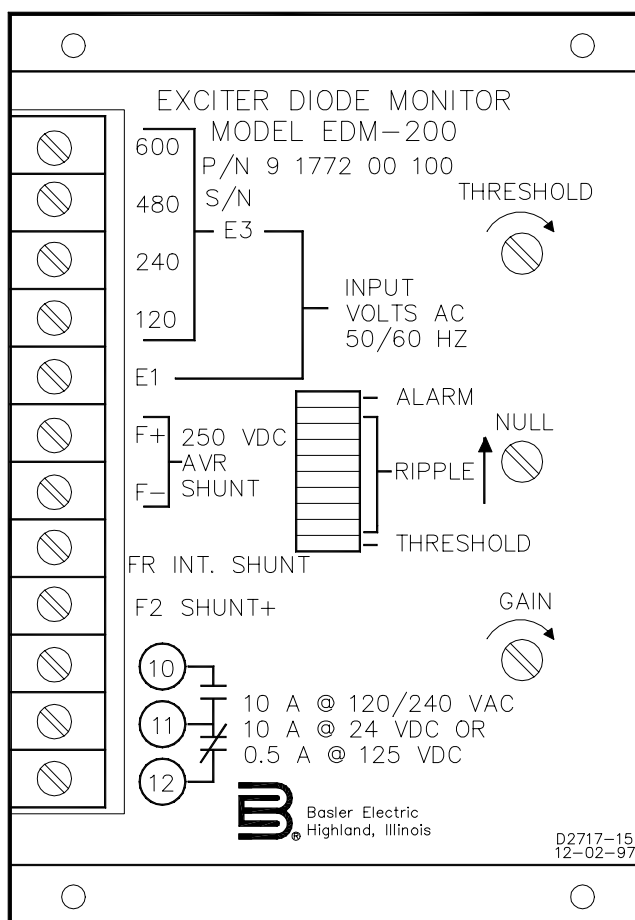

Figure 3-1. Controls and Indicator Location

# SECTION 4 • INSTALLATION AND CALIBRATION

## MOUNTING

The Exciter Diode Monitor should be mounted in a vertical position for easy viewing of the Bargraph Display. Refer to Figure 4-1 for mounting holes and dimensions.

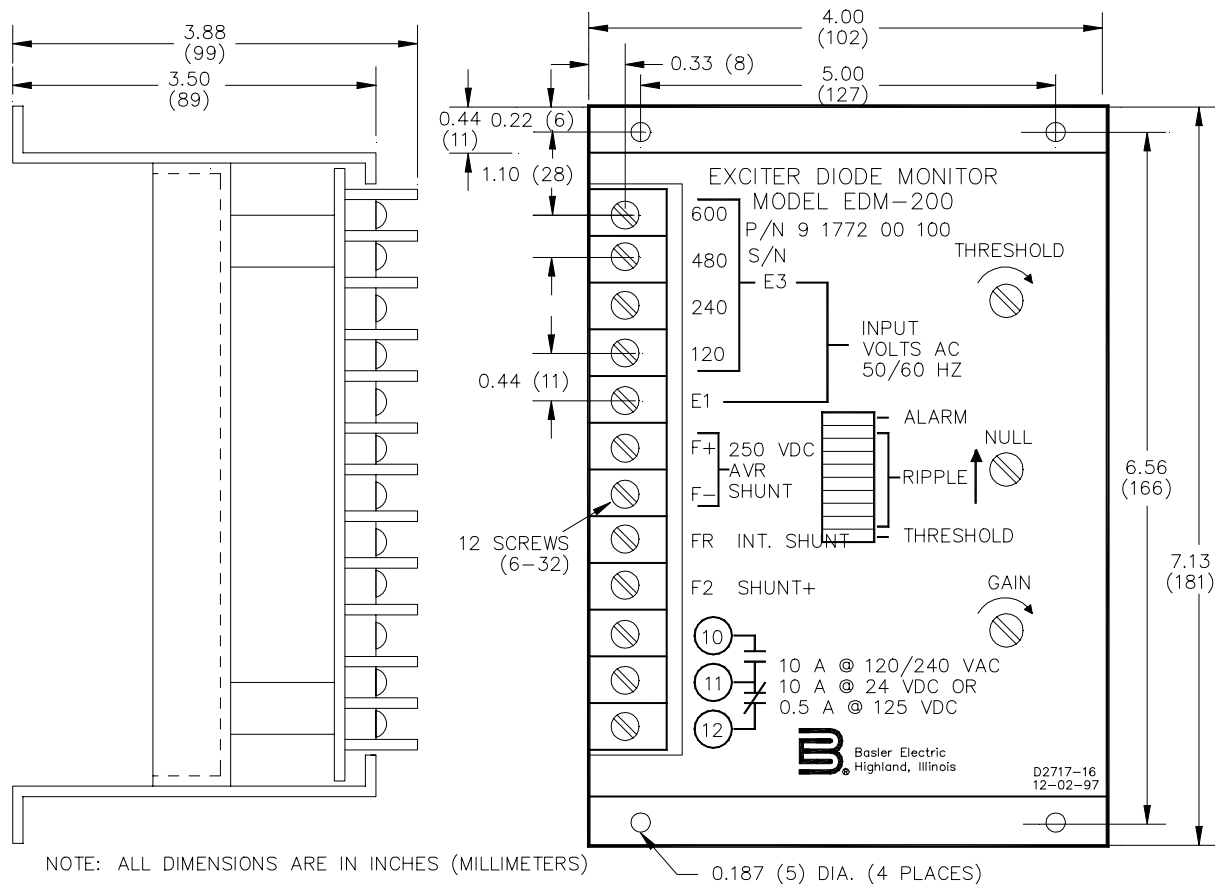

Figure 4-1. Outline Drawing

## INTERCONNECTION

Connect the Exciter Diode Monitor and other system devices in accordance with Figure 4-2 or 4-3.

## CALIBRATION - STANDARD

### Initial Adjustments

Before beginning to calibrate the Exciter Diode Monitor, set the front panel **GAIN**, **NULL**, and **THRESHOLD** controls fully counter-clockwise (CCW).

### Start-Up Procedure.

- (1) Start the generator system and check that it operates properly.
- (2) Ensure that all loads are removed.

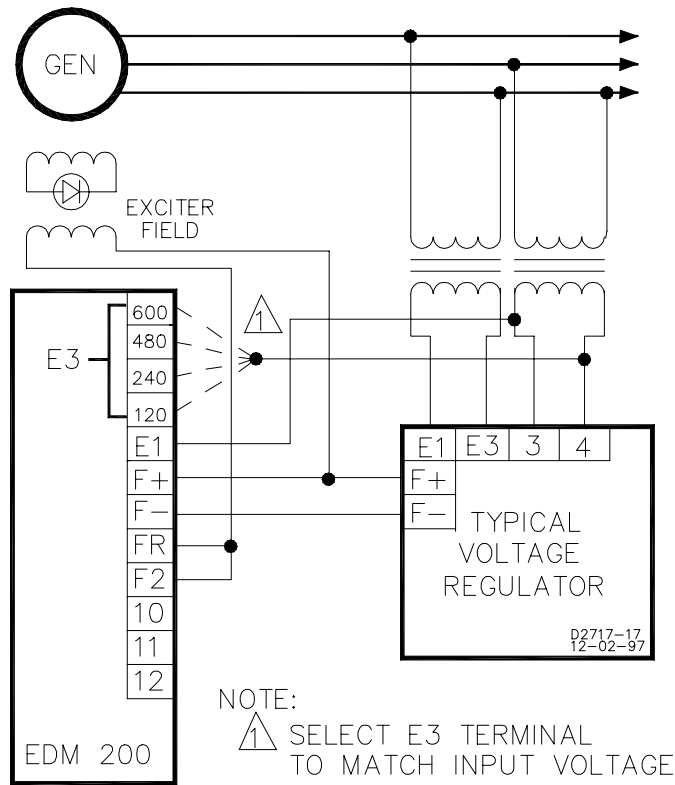

Figure 4-2. Typical Interconnection, 0 - 7 A Exciter Current

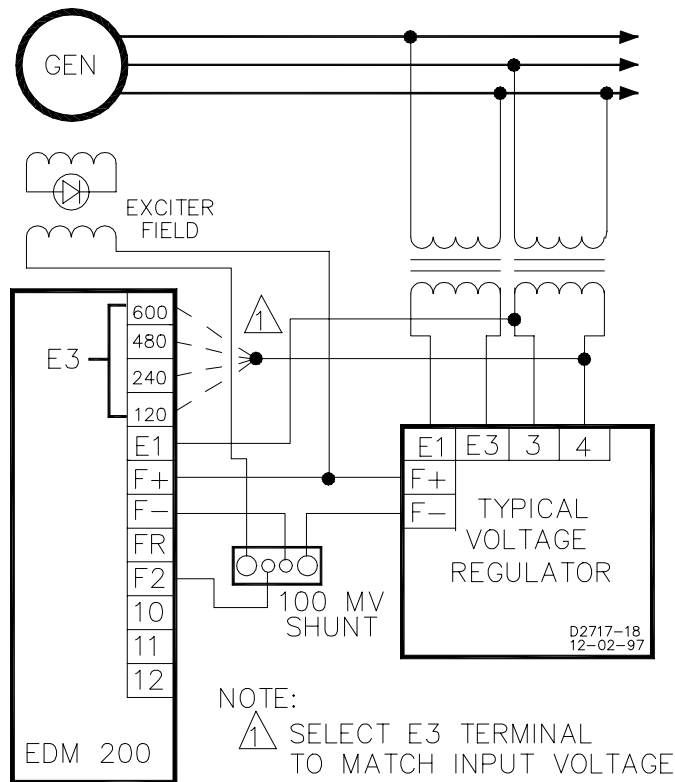

Figure 4-3. Typical Interconnection with 100 mV Shunt

- (3) Ensure that the **ALARM** and **THRESHOLD** segments of the Bargraph Display are not lit.
- (4) Rotate the front panel **THRESHOLD** control until the lowest segment (**THRESHOLD**) of the Bargraph Display just barely illuminates.
- (5) Rotate the front panel **GAIN** control until the second **RIPPLE** segment (third from the bottom) of the Bargraph Display just barely illuminates.
- (6) Rotate the front panel **NULL** control carefully until the lowest **RIPPLE** segment (second from the bottom) of the Bargraph Display is fully lit.
- (7) Rotate the front panel **GAIN** control until the second **RIPPLE** segment (third from the bottom) of the Bargraph Display just barely illuminates.
- (8) Carefully rotate the front panel **NULL** control until the lowest segment possible of the Bargraph Display is still illuminated.
- (9) Adjust the front panel **GAIN** control clockwise (CW) until the second **RIPPLE** segment (not counting the **THRESHOLD** segment) of the Bargraph Display is illuminated.

#### Trip Test

- (1) Note the number of Bargraph Display segments that are lit and the physical position (rotational) of the front panel **GAIN** control.
- (2) Slowly rotate the front panel **GAIN** control clockwise (CW) until the top **RIPPLE** segment of the Bargraph Display is lit.
- (3) After a short time delay of about 8 seconds for a shorted diode or 15 seconds for an open diode, the **ALARM** segment of the Bargraph Display will illuminate and the output Relay (K1) will "pull-in" (change state). This may be verified by checking for an open contact across terminals **11** and **12** or a closed contact across terminals **10** and **11**.
- (4) Rotate the front panel **GAIN** control back to the position noted in step (1) above and verify that the Relay de-energizes.

#### Final Checkout

After calibrating the Exciter Diode Monitor, check that it does not trip during build-up, load application, load removal, coast-down, etc.

---

## **CALIBRATION - WITH DECS UNIT**

#### Initial Adjustments

Before beginning to calibrate the Exciter Diode Monitor, set the front panel **GAIN** and **THRESHOLD** controls fully counter-clockwise (CCW). Set the front panel **NULL** control fully clock-wise (CW).

#### Start-Up Procedure

- (1) Start the generator system and check that it operates properly.
- (2) Ensure that all loads are removed.
- (3) Ensure that the **ALARM** and **THRESHOLD** segments of the Bargraph Display are not lit.
- (4) Rotate the front panel **THRESHOLD** control until the lowest segment (**THRESHOLD**) of the Bargraph Display just barely illuminates.
- (5) Rotate the front panel **GAIN** control until the second **RIPPLE** segment (third from the bottom) of the Bargraph Display just barely illuminates.
- (6) Rotate the front panel **NULL** control carefully until the lowest **RIPPLE** segment (second from the bottom) of the Bargraph Display is fully lit.

- (7) Rotate the front panel **GAIN** control until the second **RIPPLE** segment (third from the bottom) of the Bargraph Display just barely illuminates.
- (8) Carefully rotate the front panel **NULL** control until the lowest segment possible of the Bargraph Display is still illuminated.
- (9) Adjust the front panel **GAIN** control clockwise (CW) until the second **RIPPLE** segment (not counting the **THRESHOLD** segment) of the Bargraph Display is illuminated.

#### Trip Test

- (1) Note the number of Bargraph Display segments that are lit and the physical position (rotational) of the front panel **GAIN** control.
- (2) Slowly rotate the front panel **GAIN** control clockwise (CW) until the top **RIPPLE** segment of the Bargraph Display is lit.
- (3) After a short time delay of about 8 seconds for a shorted diode or 15 seconds for an open diode, the **ALARM** segment of the Bargraph Display will illuminate and the output Relay (K1) will "pull-in" (change state). This may be verified by checking for an open contact across terminals **11** and **12** or a closed contact across terminals **10** and **11**.
- (4) Rotate the front panel **GAIN** control back to the position noted in step (1) above and verify that the Relay de-energizes.

#### Final Checkout

After calibrating the Exciter Diode Monitor, check that it does not trip during build-up, load application, load removal, coast-down, etc.

# SECTION 5 • MAINTENANCE INFORMATION

---

## PREVENTIVE MAINTENANCE

Periodic inspections of the Exciter Diode Monitor should be made on a regular basis to ensure that the unit is clean and free from accumulations of dust and moisture. When inspecting the unit, check that all parts are securely mounted and that all electrical connections are clean and secure.

---

## CORRECTIVE MAINTENANCE

If a malfunction is detected in the system, use the following paragraphs to correct the malfunction. Repair is limited to the replacement of those parts identified in Table 5-1. When ordering parts from Basler Electric, always give the name, model number, and part number of the device requiring parts, and specify the reference designator, quantity, part number, and description of the desired part.

### EXCITER DIODE MONITOR DOES NOT OPERATE.

**Step 1.** Check for proper input voltage.

If input voltage is not present, repair wiring as necessary.

If input voltage is present, proceed to step 2.

**Step 2.** Replace power transistor Q3.

If this fails to remedy the problem, replace the circuit board.

### EXCITER DIODE MONITOR DOES NOT OPERATE PROPERLY.

**Step 1.** Check for incorrect wiring.

If wiring is incorrect, repair or reconnect wiring as necessary.

If wiring is correct, proceed to step 2.

**Step 2.** Recalibrate the Exciter Diode Monitor in accordance with Section 4.

If this fails to remedy the problem, replace the circuit board.

*Table 5-1. Replacement Parts.*

Reference Designator	Basler Part Number	Qty	Description
-----	9 1772 01 100	1	Printed Circuit Board
Q3	08511	1	Transistor, Power, PNP, 225 V, 2.0 A
K1	15514	1	Relay, Dustproof, SPDT; Contacts: 10 A @ 24 Vdc, 120 Vac, 240 Vac; Coil: 12 Vdc

# SECTION 6 • MANUAL CHANGE INFORMATION

---

## CHANGES

Substantive changes in this manual to date are summarized in Table 6-1.

*Table 6-1. Summary of Changes*

Revision	Summary of Changes	ECA/ECO.	Date
H	Revised the manual to add <i>Input Power Burden</i> to Table 1-1.	15589	03-96
J	Revised the manual to correct an error in Figures 3-1 and 4-1 from 50/50 Hz to 50/60 Hz. Changed the format of the manual. Added Section 6 • <i>Manual Change Information</i> .	16486	12-97
K	Changed <i>Start-Up Procedure</i> , Steps 5 and 7 in <i>Calibration Standard</i> and <i>Calibration - With DECS Unit</i> from RIPPLE segment (third from the top) to read RIPPLE segment (third from the bottom).	2478	04-99
L	Changed page ii, and corrected Page 4-3, Step (9) by changing Gain control counter-clockwise (CCW) to clockwise (CW), and added these changes to page 6-1.	9680	06/12/00